



4.0.0 | November 2012 | 3725-63706-001/A

Administrator's Guide for the Polycom[®] RealPresence[®] Group Series



Trademark Information

POLYCOM® and the names and marks associated with Polycom's products are trademarks and/or service marks of Polycom, Inc., and are registered and/or common law marks in the United States and various other countries.

All other trademarks are the property of their respective owners.

Patent Information

The accompanying product may be protected by one or more U.S. and foreign patents and/or pending patent applications held by Polycom, Inc.

© 2012 Polycom, Inc. All rights reserved.

Polycom, Inc.
6001 America Center Drive
San Jose CA 95002
USA

No part of this document may be reproduced or transmitted in any form or by any means, electronic or mechanical, for any purpose, without the express written permission of Polycom, Inc. Under the law, reproducing includes translating into another language or format.

As between the parties, Polycom, Inc., retains title to and ownership of all proprietary rights with respect to the software contained within its products. The software is protected by United States copyright laws and international treaty provision. Therefore, you must treat the software like any other copyrighted material (e.g., a book or sound recording).

Every effort has been made to ensure that the information in this manual is accurate. Polycom, Inc., is not responsible for printing or clerical errors. Information in this document is subject to change without notice.

About This Guide

The *Administrator's Guide for the Polycom RealPresence Group Series* is for administrators who need to configure, customize, manage, and troubleshoot Polycom® RealPresence® Group systems. The guide covers the RealPresence Group 300, RealPresence Group 500, and RealPresence Group 700 systems.

Please read the Polycom RealPresence Group systems documentation before you install or operate the system. The following related documents for RealPresence Group systems are available from

www.polycom.com/videodocumentation:

- *Installing Software and Options for the Polycom RealPresence Group Series and Accessories*, which describes how to install Polycom RealPresence Group systems and accessories
- *User's Guide for the Polycom RealPresence Group Series* and *User's Guide for the Polycom RealPresence Group Series and the Polycom Touch Control*, which describe how to perform video conferencing tasks
- Setup Sheets for your hardware
- Release Notes
- *Integrator's Reference Manual for the Polycom RealPresence Group Series*, which provides cable information and API command descriptions
- *Regulatory Information*, which describes safety and legal considerations for using Polycom RealPresence Group systems

For support or service, please contact your Polycom distributor or go to Polycom Support at support.polycom.com.

Polycom recommends that you record the serial number and option key of your Polycom RealPresence Group system here for future reference. The serial number for the system is printed on the unit.

System Serial Number: _____

Option Key: _____

Contents

1	Introducing the Polycom RealPresence Group Systems	1
	Polycom RealPresence Group Systems	1
	Polycom RealPresence Group 300 Systems	1
	Polycom RealPresence Group 500 Systems	1
	Polycom RealPresence Group 700 Systems	2
	Setting Up Your System Hardware	2
	Recharging the Remote Control Battery	2
	Positioning the System	3
	Positioning Polycom RealPresence Group Systems	3
	Positioning the Polycom Touch Control Device	4
	Positioning the EagleEye Acoustic Camera	4
	Positioning the Polycom EagleEye Director	5
	Powering On and Off	6
	Power-On Self Test (POST)	6
	Powering On Polycom RealPresence Group Systems	7
	Polycom RealPresence Group System Indicator Light	7
	Powering On the Polycom Touch Control Device	9
	Polycom Touch Control Indicator Light	9
	Polycom EagleEye Acoustic Camera Indicator Lights	10
	Polycom EagleEye Director Indicator Light	10
	Configuring the RealPresence Group System	11
	Setup Wizard	11
	Admin Settings	11
	Customizing the Home Screen	12
	Displaying Speed Dial Entries	13
	Displaying a Calendar	13
	Changing the Background Image	13
	Configuring Home Screen Icons	14
	Enabling Access to User Settings	14
	Restricting Access to User and Administrative Settings	15
	Customizing the Place a Call Icon	15
	Displaying the IP Address	15
	Configuring Menu Settings	16

2	Networks	17
	Getting the Network Ready	17
	Connecting to the LAN	17
	LAN Status Lights	18
	Configuring LAN Properties	18
	Configuring RealPresence Group System LAN Properties	18
	Configuring IPv4 Web-Only Settings	21
	Configuring the Polycom Touch Control LAN Properties	22
	Configuring IP Settings	23
	Specifying Network Quality Settings	24
	Specifying H.323 Settings	24
	Configuring the System to Use a Gatekeeper	25
	Configuring Integration with Avaya Networks	27
	Specifying SIP Settings	28
	Configuring SIP Settings for Integration with Microsoft Servers	31
	Configuring SIP Settings for Integration with the Telepresence Interoperability Protocol (TIP)	32
	RTV and Lync-Hosted Conference Support	32
	Specifying Quality of Service	32
	Lost Packet Recovery and Dynamic Bandwidth	34
	Configuring the System for Use with a Firewall or NAT	34
	H.460 NAT Firewall Traversal	37
	Basic Firewall/NAT Traversal Connectivity	38
	Configuring Dialing Preferences	38
	Finding Your System's IP Address	40
3	Monitors and Cameras	41
	Connecting Monitors	41
	Configuring Monitor Settings	41
	Maximizing Video Display on Your HDTV	42
	Using Sleep Settings to Prevent Monitor Burn-In	42
	Connecting Cameras	43
	Polycom EagleEye HD	43
	Polycom EagleEye 1080	44
	Polycom EagleEye View	44
	Polycom EagleEye II	44
	Polycom EagleEye III	44
	Polycom EagleEye Acoustic	45
	Polycom EagleEye Director	45
	Connecting Cameras to Polycom RealPresence Group Systems	45
	Configuring Video Input Settings	45

Configuring General Camera Settings	46
Configuring Input Settings	46
Configuring the Polycom EagleEye Director	47
Getting Started	48
Calibrating the EagleEye Director Cameras	49
Adjusting the Room View	49
Enabling and Disabling Camera Tracking with EagleEye Director	50
Configuring Camera Presets	52
Setting and Using Presets with the Remote Control or Keypad ..	52
Setting and Using Presets with the Polycom Touch Control	53
Experiencing High-Definition Video Conferencing	54
Sending Video in High Definition	54
Receiving and Displaying Video in High Definition	54
Using Full-Motion HD	55
4 Microphones and Speakers	57
Connecting Audio Input	57
Connecting Polycom RealPresence Group System Table or Ceiling Microphone Arrays	57
Using the Polycom EagleEye View and EagleEye Acoustic Microphones	58
Connecting a Polycom SoundStation IP 7000 Phone	58
Connecting Devices to the Polycom RealPresence Group 300 and RealPresence Group 500 Microphone Inputs	59
Connecting Devices to the Polycom RealPresence Group 700 Microphone Input	59
Placing Polycom Microphones to Send Stereo from Your Site	60
Polycom Microphone Lights	61
Connecting Non-Polycom Microphones or a Mixer to a Polycom RealPresence Group System	61
Connecting Audio Output	62
Placing Speakers to Play Stereo from Far Sites	62
Setting the Speaker Volume	64
Configuring Audio Settings	64
General Audio Settings	65
Audio Input	66
Audio Output	66
Stereo Settings	67
Audio Meters	68
Testing StereoSurround	68
Settings for Non-Polycom Microphones	69

5	Content	71
	Configuring VCR/DVD Player Settings	72
	Playing a Videotape or DVD	72
	Connecting Computers to Polycom RealPresence Group Systems	72
	Configuring Content Sharing	73
	Configuring Content Display with People+Content IP	73
6	Placing and Answering Calls	75
	Configuring System Settings	75
	Configuring Call Settings	75
	Setting the Call Answering Mode	77
	Configuring Multipoint Calling	77
	Entering a Multipoint Option Key	77
	Including Multiple Sites in a Cascaded Call	78
	Managing Directories with the Polycom RealPresence Group System Web Interface	79
	Directory Group Overview	79
	Global Directory Entries	79
	Managing Favorites	79
	Types of Favorites Contacts	81
	Connecting to Microsoft Exchange Server Calendaring Service	82
	Using the Web Interface Home Page	84
	Place a Call	84
	Speed Dial	85
	Recent Calls	85
	Support Documents	86
7	Security	87
	Configuring Security Options	87
	Configuring System Access for Polycom RealPresence Group Systems	88
	Configuring Local Accounts and Passwords	89
	Setting the Room and Remote Access Passwords	90
	Configuring Admin ID and Password for the Polycom Touch Control	91
	Setting a Meeting Password	92
	Enabling AES Encryption	92
	Configuring Encryption Settings for Integration with Microsoft Servers	93
	Managing Remote Access	94
	Managing User Access to Settings and Features	94

Setting up Log Management	95
Setting up Polycom RealPresence Group System Log Management .	95
Managing Polycom Touch Control Logs	95
8 Managing the System Remotely	97
Using the Polycom RealPresence Group System Web Interface	97
Accessing the Web Interface	97
Monitoring a Room or Call with the Web Interface	98
Managing System Profiles with the Web Interface	98
Sending a Message	99
Configuring Servers	100
Setting Up a Directory Server	100
Setting Up SNMP	103
Downloading MIBs	103
Configuring for SNMP Management	104
Using a Provisioning Service	105
Enabling or Disabling the Provisioning Service	106
Provisioning Service Settings	106
Keeping your Software Current	107
9 Control and Navigation	109
Configuring Remote Control Behavior	109
Configuring the Remote Control Channel ID	111
Connecting Control and Accessibility Equipment	112
Connecting Non-Polycom Touch-Panel Controls	112
Configuring RS-232 Serial Port Settings	113
Setting Up the Polycom Touch Control Device	113
Pairing and Unpairing a Polycom Touch Control Device and a Polycom RealPresence Group System	114
Pairing	116
Unpairing	116
Configuring Contact Information	117
Configuring Regional Settings	117
Configuring Polycom RealPresence Group System Location Settings	118
Configuring Polycom RealPresence Group System Language Settings	118
Configuring Polycom RealPresence Group System Date and Time Settings	118
Configuring Polycom Touch Control Regional Settings	120
Configuring Sleep Settings	121

	Customizing Sleep Behavior	121
10	Diagnostics, Status, and Utilities	123
	Diagnostics Screens	123
	System Diagnostics	124
	Network	126
	Audio and Video Tests	126
	System Logs	127
	Downloading System Logs	128
	System Log Settings	128
	Downloading EagleEye Director Logs	129
	Call Detail Report (CDR)	129
	Information in the CDR	130
11	Troubleshooting	133
	Placing a Test Call	133
	Resetting a RealPresence Group System	133
	Using the Restore Button on the Polycom RealPresence Group System ..	134
	Deleting Files	136
	Performing a Factory Restore on the Polycom Touch Control	136
	Performing a Factory Restore on the Polycom EagleEye Director	137
	How to Contact Technical Support	138
	Polycom Solution Support	138
A	System Back Panel Views	139
	Polycom RealPresence Group 300 System	139
	Polycom RealPresence Group 500 System	140
	Polycom RealPresence Group 700 System	142
B	Call Speeds and Resolutions	145
	Point-to-Point Dialing Speeds	145
	Multipoint Dialing Speeds	145
	Call Speeds and Resolutions	146
	Resolution and Frame Rates for Content Video	148

Introducing the Polycom RealPresence Group Systems

Your Polycom® RealPresence® Group system is a state-of-the-art visual collaboration tool. With crisp, clean video and crystal-clear sound, Polycom RealPresence Group systems provide natural video conferencing interaction through the most advanced video communications technology.

Polycom RealPresence Group Systems

For technical specifications and detailed descriptions of features available for RealPresence Group systems, please refer to the product literature available at www.polycom.com.

Polycom RealPresence Group 300 Systems



For smaller meeting rooms, huddle rooms, and offices, the RealPresence Group 300 system delivers high-quality and easy-to-use video collaboration at an affordable price. Single-cable connections to the camera and display simplify setup, and sharing content is easy with the Polycom People+Content™ IP application. Its sleek design is easily hidden away, or can be taken outside the room or building for mobile applications.

Polycom RealPresence Group 500 Systems



For conference rooms and other meeting environments, the RealPresence Group 500 system delivers powerful video collaboration performance in a sleek design that is easy to configure and use. Support for dual monitors and multiple options for sharing content make it an ideal fit for most standard-sized meeting rooms. Single-cable connections for video and audio simplify setup, while the small, sleek design enables discreet placement of the

device. Plus, the small design makes it ideal for mobile applications, whether moved to different locations within a building, or used as part of a mobile video kit.

Polycom RealPresence Group 700 Systems



For boardrooms, lecture halls, and other environments where only the best will do, the RealPresence Group 700 system offers extreme video collaboration performance and flexibility. Powerful video processing and flexible input and output options make it ideal for rooms with complex requirements, such as multiple displays, cameras, and content sources. The intuitive interface that comes standard on all RealPresence Group products makes it easy for even novice users to control the system and get the most out of their video collaboration experience with no hassles.

Setting Up Your System Hardware

This manual provides information to supplement the setup sheets provided with your system and its optional components. A printed copy of the system setup sheet is provided with each RealPresence Group system. PDF versions of the system setup sheets are available at support.polycom.com.

Recharging the Remote Control Battery

Your system setup sheet shows how to charge the battery in the remote control the first time. When the remote control battery power is at 10% or less, a notification is displayed on the home screen. Although other notifications override the low battery notification, the low battery notification returns after the other notifications are dismissed. The low battery notification is not displayed while the system is in a call.

The following steps describe how to recharge the battery.

To recharge the remote control battery:

- 1 Pull the battery out of the end of the remote control.
- 2 Insert the USB plug into a USB 2.0 port, such as the one on your system. The RealPresence Group 300 and RealPresence Group 500 systems have two USB 2.0 ports on the back of the system, while the RealPresence Group 700 has one port on the front of the system.
- 3 Wait until the status light on the battery turns green before removing it from the port.
- 4 Insert the charged battery into the remote control.

The following figure illustrates these steps.

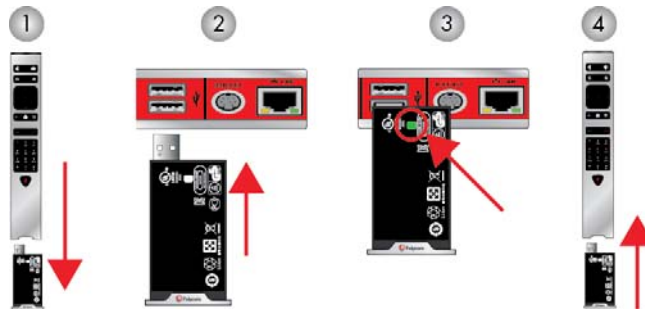

If you have a RealPresence Group 700 system, you can also recharge the battery using the USB port on the front of the system.

Positioning the System

Positioning Polycom RealPresence Group Systems

RealPresence Group systems are designed to be placed on a tabletop or in an equipment rack.

To position the system:

- 1 Do one of the following:
 - If you plan to place the system on a table or shelf, attach the self-adhesive feet to the bottom of the system.
 - If you plan to mount a RealPresence Group 700 system in an equipment rack, install the mounting brackets, as shown in the following figure.

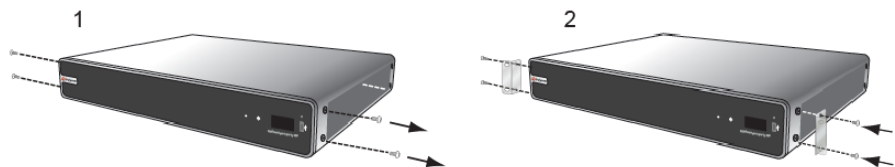

Polycom RealPresence Group 300 and RealPresence Group 500 systems use a different type of mounting bracket. For more information, refer to support.polycom.com or contact your Polycom distributor.

- 2 Place the system in the desired location. Position the system so that the camera does not face toward a window or other source of bright light. Leave enough space to connect the cables easily. Place the camera and display together so that people at your site face the camera when they are looking at the display.



Positioning the Polycom Touch Control Device

Polycom RealPresence Group systems can be controlled by the Polycom Touch Control.

Ensure that the Touch Control is conveniently located for use during a meeting.

When the Polycom Touch Control is not paired with a RealPresence Group system, the device can be used as a virtual remote control. To use the Polycom Touch Control as a virtual remote control, ensure that the infrared (IR) transmitter on the front of the device is facing the RealPresence Group system you want to control.

Positioning the EagleEye Acoustic Camera

The Polycom EagleEye Acoustic camera is designed to be placed on top of your monitor, as shown in the following diagram.



Positioning the Polycom EagleEye Director

The Polycom EagleEye Director is an automatic HD tracking system that works with RealPresence Group systems. Refer to [Polycom EagleEye Director](#) on page 45 for more information about the automatic camera positioning system.

Follow these guidelines when you use the EagleEye Director with your RealPresence Group system:

- Avoid setting the Polycom EagleEye Director in the corner of a room. The EagleEye Director should be at least 12 inches away from all of the walls.
- Make sure the EagleEye Director is on a level surface or mounting bracket.
- The camera's viewing angle is approximately 9 degrees above and 30 degrees below its direct line of sight.
- To ensure the best view from the Polycom EagleEye Director voice-tracking feature, follow these suggestions:
 - Set the EagleEye Director on top of a monitor. Ideally, place the camera between 5.5 and 7 feet from the ground.

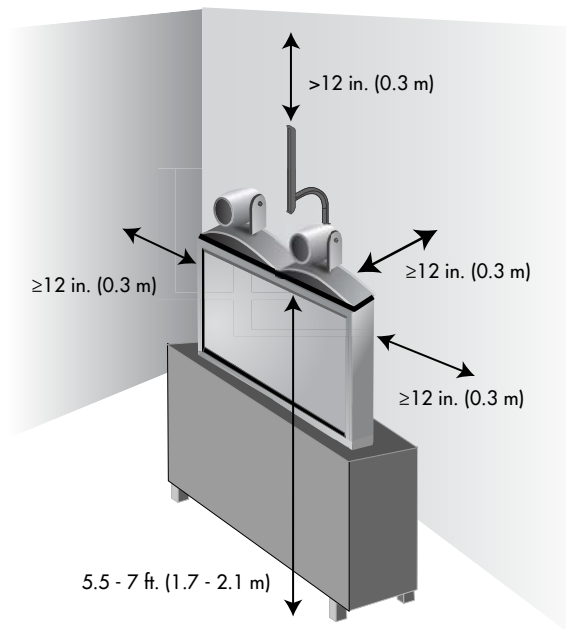
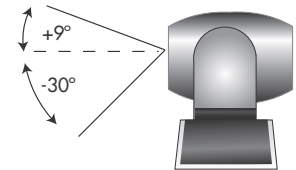

- Ensure that people are sitting within the viewing range of between 3 and 22 feet from the device.

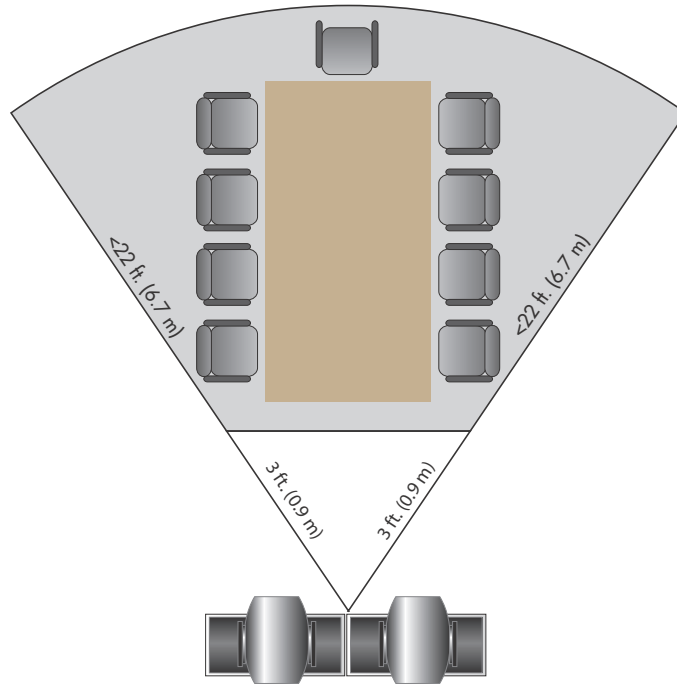

Powering On and Off

Connect power and power on the RealPresence Group System after you have connected all of the equipment that you will use with it. Make sure that the system is powered off before you connect devices to it. It is important to note that Polycom RealPresence Group systems do not have what you might think of as a power *button* – they have a power *proximity sensor*. Instead of pressing an actual button that moves, you touch the sensor (or near the sensor) that indicates power  on the front of the system.

For instructions on how to power on and off the Polycom Touch Control, refer to [Powering On the Polycom Touch Control Device](#) on page 9.

Power-On Self Test (POST)

After being powered on, the RealPresence Group systems automatically perform system health checks before the system is initialized. This process is known as a power-on self test, or POST. The status of the POST sequence is displayed with the LED indicator light on the front of the device, or in the case of the RealPresence Group 700 system, in the text field display on the front of

the device. All test results are logged in the system's memory. For more information about what the colors of the indicator lights mean, refer to [Polycom RealPresence Group System Indicator Light](#) on page 7.

When the POST sequence completes with no severe errors, the RealPresence Group system starts normally. If any warnings occur during POST, you can view them after the system starts by going to **System > Status > Active Alerts** in the local interface or **Diagnostics > System > Active Alerts** in the web interface. If a severe error occurs during startup, the system will not start up. Contact Polycom technical support.



Powering On Polycom RealPresence Group Systems

To power on the RealPresence Group System, do one of the following:

- Press any button on the remote control or pick up the remote control to wake up the system if it is asleep.
- Press  on the remote control.
- Touch the power sensor on the front of the system.

The Polycom screen is displayed within about 10 seconds.

To shut down the RealPresence Group System, do one of the following:

- Press and hold  on the remote control.
Refer to [Configuring Remote Control Behavior](#) on page 109 for more information about programming .
- Touch and hold the power sensor on the front of the system. The indicator light changes color and blinks, indicating that the system is shutting down. Release the power sensor when the indicator light changes color.

Polycom RealPresence Group System Indicator Light

The following figure shows the location of the power sensor and indicator light on the front of the Polycom RealPresence Group 300 system and RealPresence Group 500 system.

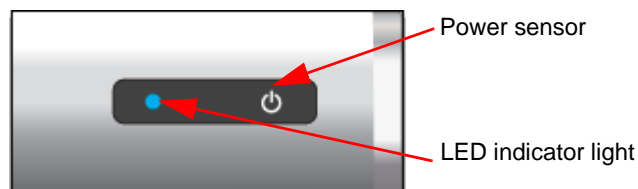

The following figure identifies the features on the front of the RealPresence Group 700 system.

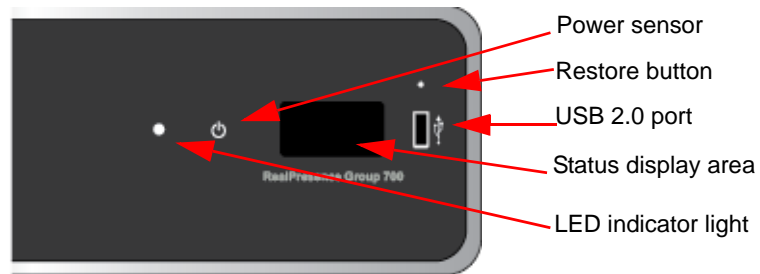

Use the USB port for any USB 2.0 device.

Brief status and diagnostic messages are displayed in the status display area of the RealPresence Group 700 system. The LED on the front of all RealPresence Group systems provides the following information.

Indicator Light	System Status
Off	System is powered off.
Blinking blue light	In a POST sequence, no errors are occurring and tests are successful. The system continues to blink blue and initializes after the sequence is complete if no severe errors occur.
Blinking amber light	In a POST sequence, at least one test has resulted in a warning error. The system continues to blink amber but initializes after the sequence is complete if no severe errors occur.
Blinking red light	In a POST sequence, at least one test has resulted in a severe error. The system continues to blink red and will not start up.
Steady blue light	System is initializing. System is awake.
Blinking blue light	System received an IR (infrared) signal. System is receiving a call.
Steady amber light	System is asleep.
Alternating blue and amber lights	System is in software update mode. System is in factory restore mode.
Fast blinking amber light	System is shutting down.
Steady green light	System is in a call.

Powering On the Polycom Touch Control Device

To power on the Polycom Touch Control:

- 1 Connect the Ethernet cable to the underside of the Polycom Touch Control.
- 2 Plug the Ethernet cable into the wall outlet.
 - If your room provides Power Over Ethernet, you can connect the Ethernet cable directly to a LAN outlet.
 - If your room does not provide Power Over Ethernet, you must connect the Ethernet cable to the optional power supply adapter. Then connect the power supply adapter to a LAN outlet and power outlet. The power supply adapter is sold separately.

The Polycom Touch Control powers on and displays the language selection screen.

To power off the Polycom Touch Control:

- 1 From the Touch Control Home screen, touch  **User Settings**.
- 2 Scroll to the Power section.
- 3 Select **Touch Control Power**.
- 4 In the menu that appears, select **Power Off the Touch Control**. If you choose to power off the Polycom Touch Control, you must disconnect and reconnect the LAN cable to power it on again.

To wake up the Polycom Touch Control:

The touch control goes to sleep after 2 minutes of inactivity. Touch the screen to wake it up.

Polycom Touch Control Indicator Light

When the Polycom Touch Control is on, the  **Home** button is lit.

Polycom EagleEye Acoustic Camera Indicator Lights

The following figure shows the location of the LED on the front of the EagleEye Acoustic camera.

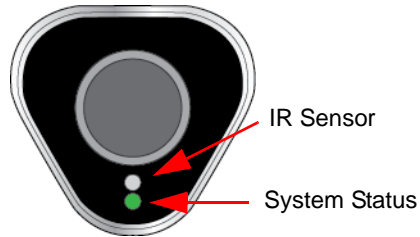

The system status light provides the following information:

Indicator Light	System Status
Steady blue light	System is on and awake.
Blinking blue light	Camera firmware is being updated.
Steady amber light	System is asleep.
Steady green light	System is in a call.

Polycom EagleEye Director Indicator Light

The following figure shows the location of the power indicator light on the back of the Polycom EagleEye Director.

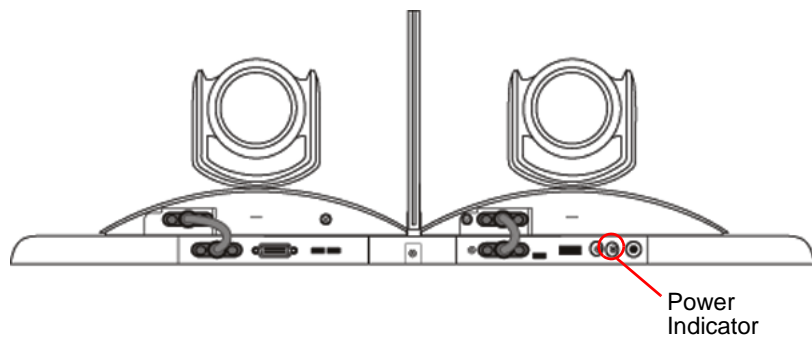

This indicator light provides the following information.

Indicator Light	Status
Steady green light	Cameras are ready.
Steady red light	Cameras are powering on.
Blinking red light	Factory restore on the cameras is starting.

Configuring the RealPresence Group System

Setup Wizard

When you power on your system for the first time, the setup wizard leads you through the minimum configuration steps required to place a call.

The setup wizard allows you to set an Admin ID and password, which allows you to limit access to the Admin Settings. The default Admin ID is *admin* and the default admin room password is the 14-digit system serial number on the **System > Information > System Detail** screen in the local interface or on the back of the system. Admin and User IDs are not case sensitive.



Make sure you can recall the room password if you set one. If you forget the password, you must use the restore button to run the setup wizard again in order to access the Admin Settings and reset the password.

You can run the setup wizard or view the configuration screens in either of the following two ways.

- **In the room with the system** — You can navigate the screens and enter information by using the remote control and the onscreen keyboard. When you reach a text field, press the **Select** button on the remote control to display the onscreen keyboard. Note that the onscreen is automatically displayed when you reach the **System Name** field in the setup wizard. Be aware that only those configuration screens needed to get the system connected are included in the local interface. Most of the administrative settings are available only in the web interface.
- **From a remote location** — If you know the IP address of the system, you can access and configure it using the web interface. For more information about using the web interface, refer to [Using the Polycom RealPresence Group System Web Interface](#) on page 97.

The setup wizard is available during initial setup, after a system reset with system settings deleted, or after using the restore button.

Admin Settings

After you run the setup wizard, you can view or change the system's configuration by going to the **Administration** in the system's local interface or **Admin Settings** in the web interface. The local interface has a subset of the Administration settings that are available in the web interface.



When a RealPresence Group System is paired with a Polycom Touch Control, the following statements are true:

- You can change the system's configuration using the web interface only.
- When prompted to enter the Admin Room ID and password and no Admin Room ID is configured, you can submit a blank password.

If you enable a provisioning service, any settings provisioned by the Polycom Converged Management Application® (CMA®) or Polycom RealPresence® Resource Manager system might be displayed as read-only settings in the Admin Settings. For more information about automatic provisioning, refer to the Polycom CMA or RealPresence Resource Manager system documentation on the Polycom web site.

The Polycom Touch Control has separate admin settings that allow you to update Touch Control software and configure LAN, regional, and security properties for the Touch Control. Refer to the following sections for more information:

- [Configuring the Polycom Touch Control LAN Properties](#) on page 22
- [Configuring Polycom Touch Control Regional Settings](#) on page 120
- [Configuring Admin ID and Password for the Polycom Touch Control](#) on page 91
- [Managing Polycom Touch Control Logs](#) on page 95

An admin ID and password might be configured for the Touch Control Administration settings. The default ID is *admin* and the default password is *456*.

Customizing the Home Screen



Home screen customizations have no effect when the RealPresence Group system is paired with a Polycom Touch Control.

Use the Polycom RealPresence Group system's web interface to configure how information is displayed on the Home screen of the local interface.

To configure the Home screen using the web interface:

- 1 In your web browser address line, enter the RealPresence Group system's IP address.
- 2 Go to **Admin Settings > General Settings > Home Screen Settings**.
- 3 Configure the settings on the Home Screen Settings page that are described in the following sections.

Displaying Speed Dial Entries

You use speed dialing to quickly call an IP address designated as a Favorite.

**Points to note about speed dial entries:**

- To place a call within your company's telephone system, enter the internal extension instead of the full number.
- Speed dial entries do not appear when the Polycom RealPresence Group system is paired with a Polycom Touch Control.

To enable speed dialing in the web interface:

- 1 Go to **Admin Settings > General Settings > Home Screen Settings**.
- 2 In the **Speed Dial** section, click the **Choose Favorites** link to create and select the favorites you want to designate as speed dial entries.
- 3 Select the **Enable Speed Dial** setting.

For more information about calling, adding, or removing speed dial entries, refer to [Speed Dial](#) on page 85.

Displaying a Calendar

If your RealPresence Group system is configured to connect to the Microsoft Exchange Server, you can view scheduled meetings on the Home screen. If no meetings appear on the Home screen, either the system is not connected to the Microsoft Exchange Server or no meetings are scheduled.

For more information about using the calendar, refer to the *User's Guide for the Polycom RealPresence Group Series*.

Changing the Background Image

The local interface of the RealPresence Group systems displays a default background image that's similar to a computer's "wallpaper." You cannot delete this image, but you can upload your own image to replace it.

The pixel size of the image you upload must be 1920 x 1080 and the image format must be JPEG.

To upload and use a background image:

- 1 In the web interface, go to **Admin Settings > General Settings > Home Screen Settings > Background**.
- 2 Click **Choose File** to search for and select the image you want to upload.
- 3 When the image name appears next to **Choose File**, click **Upload** to display the image as your background.

Configuring Home Screen Icons

Home Screen Icons are the icons that appear in the lower center of the local interface, three at a time. By default, users see the icons shown in the following table in this location.

Icon	Name
	Menu
	Content
	System
	Administration
	Place a Call

Enabling Access to User Settings

To enable access to User settings:

- 1 Do one of the following:
 - In the local interface, go to **Administration > Security > Settings**.
 - In the web interface, go to **Admin Settings > Security > Global Security > Access**.
- 2 Enable the **Allow Access to User Settings** setting.

If you enable access to user settings, users see the **User Settings** icon () after the **System** icon.

Restricting Access to User and Administrative Settings

You can restrict access to **User Settings** and **Administration Settings**, making them available only through the web interface.

To prevent users from using User Settings or Administration Settings in the local interface:

>> In **Admin Settings > General Settings > Home Screen Settings > Home Screen Icons**, disable the **Show icons on the home screen** setting.



If the following conditions are met, the ability to show icons is automatically enabled and read only:

- Speed Dial is disabled in the **Admin Settings > General Settings > Home Screen Settings**
- The Calendar is not displayed because the system is not connected to the Microsoft Exchange Server
- Remote Access through the Web, Telnet, and SNMP is disabled in **Security > Global Security > Access**

Customizing the Place a Call Icon

You can choose where selecting  takes the user.

To choose where the local interface takes users when they select Place a Call:

>> In **Admin Settings > General Settings > Home Screen Settings > Home Screen Icons**, select one of the following locations:

- Keypad
- Contacts
- Recent Calls

Displaying the IP Address

By default, the RealPresence Group system's IP address is displayed in the lower left corner of the local interface's Home Screen. You can disable the **Show IP Address** setting if you don't want users to see the system's IP address in that location.

Configuring Menu Settings

The menu settings in the web interface determine some of the information that is displayed in the local interface's main menu. The menu settings are pulled from the system's network settings. For more information about network settings, refer to [Chapter 2, Networks](#), on page 17.

To configure local interface menu settings:

- 1 In the web interface, go to **Admin Settings > General Settings > Menu Settings**.
- 2 Configure these settings.

Setting	Description
Show System Information	Specifies whether to show certain system information in the menu: <ul style="list-style-type: none">• The system's SIP Address• The system's IP Address• The Extension associated with the system
Show System Button	Specifies whether to show a System button in the menu. Note: The System button in the local interface's main menu is not the same as the System link in the blue bar at the top of the web interface page.

Networks

This guide covers network types used worldwide. Note that not all network types are available in all countries.

Getting the Network Ready

Before you begin configuring the network options, you must make sure your network is ready for video conferencing.

Polycom also offers contract high-definition readiness services. For more information, please contact your Polycom distributor.

Connecting to the LAN

You must connect the system to a LAN to:

- Make H.323 or SIP calls
- Use a Global Directory Server
- Register with a management system
- Access the web interface
- Use People+Content™ IP
- Connect to the Polycom Touch Control

LAN Status Lights

The LAN connector on the RealPresence Group systems has two lights to indicate connection status and traffic.

Indicator Light	Connection Status
Left light off	No 1000Base-T connection.
Left light green	1000Base-T connection.
Right light off	No 10/100 Base-T connection and no network traffic with 1000 Base-T connection.
Right light on	10/100 Base-T connection and blinks with network traffic.
Right light blinking	Network traffic.

Configuring LAN Properties

You can configure LAN properties for the RealPresence Group systems and for Polycom Touch Control Devices. Refer to the following section and [Configuring the Polycom Touch Control LAN Properties](#) on page 22.

Configuring RealPresence Group System LAN Properties

To configure RealPresence Group System LAN properties:

- 1 Do one of the following:
 - In the local interface, go to **Administration > LAN Properties**.
 - In the web interface, go to **Admin Settings > Network > LAN Properties**.

- 2 Configure the following **IP Address (IPv4)** settings on the LAN Properties screen.

Setting	Description
IP Address (in the local interface: Set IP Address)	Specifies how the system obtains an IP address. <ul style="list-style-type: none"> • Obtain IP Address Automatically — Select if the system gets an IP address from the DHCP server on the LAN. • Enter IP Address Manually — Select if the IP address will not be assigned automatically.
Your IP Address is (in the local interface: IP Address)	If the system obtains its IP address automatically, this area displays the IP address currently assigned to the system. If you selected Enter IP Address Manually , enter the IP address here.
Default Gateway	Displays the gateway currently assigned to the system. If the system does not automatically obtain a gateway IP address, enter one here.
Subnet Mask	Displays the subnet mask currently assigned to the system. If the system does not automatically obtain a subnet mask, enter one here.

- 3 Configure the following **DNS Servers** settings on the LAN Properties screen.

Setting	Description
DNS Servers (in the local interface: DNS)	Displays the DNS servers currently assigned to the system. When the IPv4 address is obtained automatically, the DNS Server addresses are also obtained automatically. In the web interface, you can specify IPv4 DNS server addresses only when the IPv4 address is entered manually. In the local interface, the four DNS server address fields are always editable.
Static IP Address (web only)	In the web interface, if the system does not automatically obtain a DNS server address, you can click Add a static address to display this setting and enter a DNS server address here. Up to four DNS server addresses are allowed. If all four address fields show addresses, you will be unable to add another.

4 Configure the following **LAN Options** settings on the LAN Properties screen.

In the web interface, these settings are displayed within LAN Options, but in the local interface they are arranged differently.

Setting	Description
Autonegotiation (under General Settings in local interface)	Specifies whether the network switch should automatically negotiate the LAN speed and duplex mode. If this setting is enabled, the LAN Speed and Duplex Mode settings become read only. Polycom and IEEE802.3 recommend that you use autonegotiation to avoid network issues.
LAN Speed (under General Settings in local interface)	Specifies whether to use 10 Mbps , 100 Mbps , or 1000 Mbps for the LAN speed. Note that the speed you choose must be supported by the switch.
Duplex Mode (under General Settings in local interface)	Specifies the duplex mode to use. Note that the Duplex mode you choose must be supported by the switch.
Enable EAP/802.1X	Specifies whether EAP/802.1X network access is enabled. RealPresence Group systems support the following authentication protocols: <ul style="list-style-type: none"> • EAP-MD5 • EAP-PEAPv0 (MSCHAPv2) • EAP-TTLS • EAP-TLS
Identity	Specifies the system's identity used for 802.1X authentication. This setting is available only when EAP/802.1X is enabled.
Password	Specifies the system's password used for 802.1X authentication. This setting is required when EAP/802.1X is enabled. The field cannot be blank.
Enable 802.1p/Q	Specifies whether VLAN and link layer priorities are enabled.
VLAN ID	Specifies the identification of the Virtual LAN. This setting is available only when 802.1p/Q is enabled. The value can be any number from 1 to 4094.

Setting	Description
Video Priority	Sets the link layer priority of video traffic on the LAN. Video traffic is any RTP traffic consisting of video data and any associated RTCP traffic. This setting is available only when 802.1p/Q is enabled. The value can be any number from 0 to 7, although 6 and 7 are not recommended.
Audio Priority	Sets the priority of audio traffic on the LAN. Audio traffic is any RTP traffic consisting of audio data and any associated RTCP traffic. This setting is available only when 802.1p/Q is enabled. The value can be any number from 0 to 7, although 6 and 7 are not recommended.
Control Priority	<p>Sets the priority of control traffic on the LAN. Control traffic is any traffic consisting of control information associated with a call:</p> <ul style="list-style-type: none"> • H.323—H.225.0 Call Signaling, H.225.0 RAS, H.245, Far End Camera Control • SIP—SIP Signaling, Far End Camera Control, Binary Floor Control Protocol (BFCP) <p>This setting is available only when 802.1p/Q is enabled. The value can be any number from 0 to 7, although 6 and 7 are not recommended.</p>
Enable PC LAN Port	<p>The setting appears only for RealPresence Group 700 systems.</p> <p>Specifies whether the PC LAN port is enabled on the back of the system. Disable this setting for increased security.</p>

Configuring IPv4 Web-Only Settings

The following LAN options apply only to IPv4 environments and are available only on the web interface.

Setting	Description
Host Name	Indicates the system's DNS name.
Domain Name	<p>Displays the domain name currently assigned to the system.</p> <p>If the system does not automatically obtain a domain name, enter one here.</p>
Ignore Redirect Messages	Enables the RealPresence Group system to ignore redirect messages from network routers. A redirect message tells the endpoint to use a different router than the one it is using.

Setting	Description
ICMP Transmission Rate Limit (millisec)	Specifies the minimum number of milliseconds between transmitted packets. Enter a number between 0 and 60000. The default value of 1000 signifies that the system sends 1 packet per second. If you enter 0, the transmission rate limit is disabled. This setting applies only to "error" ICMP packets. This setting has no effect on "informational" ICMP packets, such as echo requests and replies.
Generate Destination Unreachable Messages	Generates a Destination Unreachable message if a packet cannot be delivered to its destination for reasons other than network congestion.
Respond to Broadcast and Multicast Echo Requests	Sends an Echo Reply message in response to a broadcast or multicast Echo Request , which is not specifically addressed to the RealPresence Group system.

Configuring the Polycom Touch Control LAN Properties

To configure Polycom Touch Control LAN settings:

- 1 From the Home screen, touch  **Administration**.
- 2 Touch the **LAN Properties** tab.
- 3 Configure the following **IP Address (IPv4)** settings.

Setting	Description
Set IP Address	Specifies how the Touch Control obtains an IP address. <ul style="list-style-type: none"> • Obtain IP address automatically — Select if the Touch Control gets an IP address from the DHCP server on the LAN. • Enter IP address manually — Select if the IP address is not automatically assigned.
IP Address	Displays the IP address currently assigned to the Touch Control, if the Touch Control obtains its IP address automatically. If you selected Enter IP address manually , enter the IP address here.

Setting	Description
Subnet Mask	Displays the subnet mask currently assigned to the Touch Control. If you selected Enter IP address manually , enter the subnet mask here.
Default Gateway	Displays the gateway currently assigned to the Touch Control. If you selected Enter IP address manually , enter the gateway IP address here.

4 Configure the following **DNS** settings.

Setting	Description
Domain Name	Displays the domain name currently assigned to the Touch Control. If the Touch Control does not automatically obtain a domain name, enter one here.
DNS Servers	Displays the DNS servers currently assigned to the Touch Control. If the Touch Control does not automatically obtain a DNS server address, enter up to two DNS servers here. You can specify IPv4 DNS server addresses only when the IPv4 address is entered manually. When the IPv4 address is obtained automatically, the DNS Server addresses are also obtained automatically.

5 Optionally, view the general settings.

Setting	Description
Duplex Mode	Displays the duplex mode.
LAN Speed	Displays the LAN speed.

Configuring IP Settings

You can configure IP network settings only through the web interface by going to **Admin Settings > Network > IP Network**.

Specifying Network Quality Settings

Use this group of settings to specify how your RealPresence Group system responds to quality issues.

Setting	Description
Automatically Adjust People/Content Bandwidth	Specifies whether the system should automatically adjust the bandwidth necessary for the People stream or Content stream depending on the relative complexity of the people video, content video, or both. This setting is not available if you select a Quality Preference .
Quality Preference	Specifies which stream has precedence when attempting to improve network quality issues: <ul style="list-style-type: none"> • Both People and Content Streams • People Streams • Content Streams This setting is not available when the Automatically Adjust People/Content Bandwidth setting is enabled.

Specifying H.323 Settings

If your network uses a gatekeeper, the system can automatically register its H.323 name and extension. This allows others to call the system by entering the H.323 name or extension instead of the IP address.

Setting	Description
Enable IP H.323	Allows the H.323 settings to be displayed and configured.
Display H.323 Extension	Causes a new field to be displayed on the home screen that allows users to enter H.323 extensions separately from the gatekeeper IP address on the Place a Call screen. If you do not select this setting, users make gatekeeper calls by entering the call information in this format: gatekeeper IP address + ## + extension

Setting	Description
H.323 Name	<p>Specifies the name that gatekeepers and gateways use to identify this system. You can make point-to-point calls using H.323 names if both systems are registered to a gatekeeper.</p> <p>The H.323 Name is the same as the System Name, unless you change it. Your organization's dial plan might define the names you can use.</p>
H.323 Extension (E.164)	<p>Lets users place point-to-point calls using the extension if both systems are registered with a gatekeeper, and specifies the extension that gatekeepers and gateways use to identify this system.</p> <p>Your organization's dial plan might define the extensions you can use.</p>

Configuring the System to Use a Gatekeeper

A gatekeeper manages functions such as bandwidth control and admission control. The gatekeeper also handles address translation, which allows users to make calls using static aliases instead of IP addresses that can change each day.

To configure the system to use a gatekeeper:

- 1 In the web interface, go to **Admin Settings > Network > IP Network > H.323 Settings**.
- 2 Configure the following settings.

Setting	Description
Use Gatekeeper	<p>Select this setting to use a gatekeeper. Gateways and gatekeepers are required for calls between IP and ISDN.</p> <ul style="list-style-type: none"> • Off — Calls do not use a gatekeeper. • Auto — System attempts to automatically find an available gatekeeper. • Specify — Calls use the specified gatekeeper. This option must be selected to enable H.235 Annex D Authentication. • Specify with PIN — Calls use the specified E.164 address and require an Authentication PIN. This setting is available only when Avaya® H.323 interoperability is being used.

Setting	Description
Require Authentication	Enables support for H.235 Annex D Authentication. When H.235 Annex D Authentication is enabled, the H.323 gatekeeper ensures that only trusted H.323 endpoints are allowed to access the gatekeeper. This setting is available when Use Gatekeeper is set to Specify with PIN .
Current Gatekeeper IP Address	If you chose Off for the Use Gatekeeper field, the Current Gatekeeper IP Address field is not displayed. Displays the IP address that the gatekeeper is currently using.
Primary Gatekeeper IP Address	<ul style="list-style-type: none"> If you chose Off for the Use Gatekeeper field, the Primary Gatekeeper IP Address field is not displayed. If you chose to use an automatically selected gatekeeper, this area displays the gatekeeper's IP address. If you chose to specify a gatekeeper, enter the gatekeeper's IP address or name (for example, 10.11.12.13 or gatekeeper.companyname.usa.com). <p>The primary gatekeeper IP address contains the IPv4 address with which the system registers. As part of the gatekeeper registration process, the gatekeeper might return alternate gatekeepers. If communication with the primary gatekeeper is lost, the RealPresence Group System registers with the alternate gatekeeper but continues to poll the primary gatekeeper. If the system reestablishes communications with the primary gatekeeper, the RealPresence Group System unregisters from the alternate gatekeeper and reregisters with the primary gatekeeper.</p>
User Name	When authentication is enabled, specifies the user name for authentication with H.235 Annex D.
Password	When authentication is enabled, specifies the password for authentication with H.235 Annex D.
Authentication PIN	Specifies the password PIN to use for authentication with the Avaya Communication Manager®. This setting is available when Use Gatekeeper is set to Specify with PIN .



Polycom RealPresence Group 300 systems cannot be enabled for multipoint calling.

Configuring Integration with Avaya Networks

Polycom RealPresence Group systems can use the following features on an Avaya telephony network:

- Call forwarding (all, busy, no answer) – Configured by the Avaya Communication Manager administrator and implemented by the user
- Call coverage – Configured by the Avaya Communication Manager administrator
- Transfer – Implemented via flash hook and dialing digits
- Audio conference – Implemented via flash hook and dialing digits
- Call park
- Answer back
- DTMF tones for Avaya functions

Refer to the Avaya documentation and the *User's Guide for the Polycom RealPresence Group Series* for information about these features.



AES Encryption is not supported for systems registered to an Avaya H.323 gatekeeper.

To configure the Polycom RealPresence Group system to use Avaya network features:

- 1** In the web interface, go to **Admin Settings > Network > IP Network > H.323**.
- 2** Set **Use Gatekeeper to Specify with PIN**.
 - a** Enter the **H.323 Extension (E.164)** provided by the Avaya Communication Manager administrator.
 - b** Enter the Avaya Communication Manager IP address for **Gatekeeper IP Address**.
 - c** Enter the **Authentication PIN** provided by the Avaya Communication Manager administrator.
- 3** In the web interface, go to **Admin Settings > Network > Dialing > Preference > Dialing Options**.
- 4** Set **Enable H.239**.

- 5 Do one of the following:
 - In the local interface, go to **User Settings > Meetings**.
 - In the web interface, go to **Admin Settings > General Settings > System Settings > Call Settings**.
- 6 Set **Auto Answer Point-to-Point Video** and **Auto Answer Multipoint Video** to **No**.

Specifying SIP Settings

If your network supports the Session Initiation Protocol (SIP), you can use SIP to connect IP calls.

To specify SIP Settings:

- 1 In the web interface, go to **Admin Settings > Network > IP Network > SIP**.
- 2 Configure these settings.



If you installed the Microsoft real-time video (RTV) software option key, several of the SIP configuration fields described in the following table are named differently to align with Microsoft terminology.

Setting	Description
Enable SIP	Allows the SIP settings to be displayed and configured.
SIP Server Configuration	Specifies whether to automatically or manually set the SIP server's IP address. If you select Auto , the Transport Protocol, Registrar Server, and Proxy Server settings cannot be edited. If you select Specify , those settings are editable.

Setting	Description
Transport Protocol	<p>Indicates the protocol the system uses for SIP signaling. The SIP network infrastructure your RealPresence Group System operates within determines which protocol is required.</p> <p>Auto enables an automatic negotiation of protocols in the following order: TLS, TCP, UDP. This is the recommended setting for most environments.</p> <p>TCP provides reliable transport via TCP for SIP signaling.</p> <p>UDP provides best-effort transport via UDP for SIP signaling.</p> <p>TLS provides secure communication of the SIP signaling. TLS is available only when the system is registered with a SIP server that supports TLS. When you choose this setting, the system ignores TCP/UDP port 5060.</p>
User Name	<p>Specifies the SIP address or SIP name of the system, for example, mary.smith@department.company.com. If you leave this field blank, the system's IP address is used for authentication.</p> <p>Note: If you have installed the real-time video (RTV) option key, this setting is named Sign-in Address.</p>
Domain User Name	<p>Specifies the name to use for authentication when registering with a SIP Registrar Server, for example, msmith@company.com. If the SIP proxy requires authentication, this field and the password cannot be blank.</p> <p>Note: If you have installed the RTV option key, this setting is named User Name.</p>
Password	<p>Specifies the password that authenticates the system to the Registrar Server.</p>

Setting	Description
<p>Registrar Server</p>	<p>Specifies the IP address or DNS name of the SIP Registrar Server.</p> <ul style="list-style-type: none"> In a Microsoft Office Communications Server 2007 R2 or Microsoft Lync Server 2010 environment, specify the IP address or DNS name of the Office Communications Server or Lync Server server. If registering a remote RealPresence Group System with an Office Communications Server Edge Server or Lync Server Edge Server, use the fully qualified domain name of the access edge server role. <p>By default for TCP, the SIP signaling is sent to port 5060 on the registrar server. By default for TLS, the SIP signaling is sent to port 5061 on the registrar server.</p> <p>Enter the IP address and port using the following format: <IP_Address>:<Port> <IP_Address> can be an IPv4 address or a DNS hostname such as <code>servername.company.com:6050</code>. Hostnames can resolve to IPv4 addresses.</p> <p>Note: If you have installed the RTV option key, this setting is named Server name or IP address.</p> <p>Syntax Examples:</p> <ul style="list-style-type: none"> To use the default port for the protocol you have selected: 10.11.12.13 To specify a different TCP or UDP port: 10.11.12.13:5071
<p>Proxy Server</p>	<p>Specifies the DNS name or IP address of the SIP Proxy Server. If you leave this field blank, the Registrar Server is used. If you leave both the SIP Registrar Server and Proxy Server fields blank, no Proxy Server is used.</p> <p>By default for TCP, the SIP signaling is sent to port 5060 on the proxy server. By default for TLS, the SIP signaling is sent to port 5061 on the proxy server.</p> <p>The syntax used for this field is the same as for the Registrar Server field.</p> <p>Note: If you have installed the RTV option key, this setting is hidden. In Microsoft networks, the Proxy server and the Registrar server are always the same server, so only one server address field is required.</p>

For more information about this and other Microsoft/Polycom interoperability considerations, refer to the *Polycom Unified Communications Deployment Guide for Microsoft Environments*.



Points to note about SIP:

The SIP protocol has been widely adapted for voice over IP communications and basic video conferencing; however, many of the advanced video conferencing capabilities are not yet standardized. Many capabilities also depend on the SIP server.

The following are examples of features that are not supported using SIP:

- Cascaded multipoint in SIP calls.
- Meeting passwords. If you set a meeting password, SIP endpoints will be unable to dial in to a multipoint call.

For more information about SIP compatibility issues, refer to the *Release Notes for Polycom® RealPresence® Group Systems*.

Configuring SIP Settings for Integration with Microsoft Servers

Integration with Microsoft Office Communications Server 2007 R2 and Microsoft Lync Server 2010 allows Office Communicator and Polycom RealPresence Group system users to place audio and video calls to each other.



Because Polycom RealPresence Group systems run in dynamic management mode, they cannot be simultaneously registered with Office Communications Server or Lync Server and the presence service provided by the Polycom Converged Management Service (CMA) or Polycom RealPresence Resource Manager system. RealPresence Group systems can obtain presence services from only one source: Office Communications Server and Lync Server, or the presence service provided by the CMA or RealPresence Resource Manager system.

Polycom supports the following features in Microsoft Office Communications Server 2007 R2 and Microsoft Lync Server 2010:

- Interactive Connectivity Establishment (ICE)
- Centralized Conferencing Control Protocol (CCCP)
- Federated presence
- Real-time video

For more information about this and other Microsoft/Polycom interoperability considerations, refer to the *Polycom Unified Communications Deployment Guide for Microsoft Environments*.

If your organization deploys multiple Office Communications Server and Lync Server pools, a Polycom RealPresence Group system must be registered to the same pool to which the system's user account is assigned.

Configuring SIP Settings for Integration with the Telepresence Interoperability Protocol (TIP)

When SIP is enabled on a RealPresence Group system that has the TIP option key, the system can interoperate with TIP endpoints.



Points to note about TIP:

- Polycom RealPresence Group systems cannot host multipoint calls while in a SIP (TIP) call.
- SIP (TIP) calls must connect at a call speed of 1 Mbps or higher.
- Only TIP version 7 is supported.
- In a TIP call, only XGA content at 5 fps is supported. The following content sources are not supported in TIP calls:
 - USB content from the Polycom Touch Control
 - People+Content IP®

For more information about Polycom support for the TIP protocol, refer to the *Polycom Unified Communications Deployment Guide for Cisco Environments*.

RTV and Lync-Hosted Conference Support

To use RTV in a Lync-hosted conference, you must have the RTV option key enabled on your RealPresence Group system.

For more information about configuring your Lync Server video settings for RTV, refer to the *Polycom Unified Communications Deployment Guide for Microsoft Environments*.

Specifying Quality of Service

Set the Quality of Service options for the way your network handles IP packets during video calls.

To configure quality of service settings:

- 1 In the web interface, go to **Admin Settings > Network > IP Network > Quality of Service**.

2 Configure these settings.

Setting	Description
Type of Service	Specifies your service type and lets you choose how to set the priority of IP packets sent to the system for video, audio, and far-end camera control: <ul style="list-style-type: none"> • IP Precedence — Represents the priority of IP packets sent to the system. The value can be between 0 and 5. • DiffServ — Represents a priority level between 0 and 63.
Video	Specifies the IP Precedence or Diffserv value for video RTP traffic and associated RTCP traffic.
Audio	Specifies the IP Precedence or Diffserv value for audio RTP traffic and associated RTCP traffic.
Control	Specifies the IP Precedence or Diffserv value for control traffic on any of the following channels: <ul style="list-style-type: none"> • H.323—H.225.0 Call Signaling, H.225.0 RAS, H.245, Far End Camera Control • SIP—SIP Signaling, Far End Camera Control, Binary Floor Control Protocol (BFCP)
Maximum Transmission Unit Size	Specifies whether to use the default Maximum Transmission Unit (MTU) size for IP calls or select a maximize size.
Maximum Transmission Unit Size Bytes	Specifies the MTU size, in bytes, used in IP calls. If the video becomes blocky or network errors occur, packets might be too large; decrease the MTU. If the network is burdened with unnecessary overhead, packets might be too small; increase the MTU.
Enable Lost Packet Recovery	Allows the system to use LPR (Lost Packet Recovery) if packet loss occurs.
Enable RSVP	Allows the system to use Resource Reservation Setup Protocol (RSVP) to request that routers reserve bandwidth along an IP connection path. Both the near site and far site must support RSVP in order for reservation requests to be made to routers on the connection path.
Dynamic Bandwidth	Specifies whether to let the system automatically find the optimum line speed for a call.

Setting	Description
Maximum Transmit Bandwidth	Specifies the maximum transmit line speed between 64 kbps and the system's maximum line rate.
Maximum Receive Bandwidth	Specifies the maximum receive line speed between 64 kbps and the system's maximum line rate.
Note: When a RealPresence Group 500 or RealPresence Group 700 system is hosting a multipoint call, the total dialing speed for all sites in the call is 6 Mbps.	

Lost Packet Recovery and Dynamic Bandwidth

You can handle video quality issues by selecting the **Enable Lost Packet Recovery (LPR)** setting, the **Dynamic Bandwidth** setting, or both settings.

If both settings are enabled, Dynamic Bandwidth adjusts the video rate to reduce packet loss to 3% or less. When packet loss drops to 3% or less, LPR cleans up the video image on your monitor. The additional processing power required might cause the video rate to drop while the system is using LPR. If this happens, the Call Statistics screen shows the Video Rate Used as lower than the Video Rate. If Packet Loss is 0 for at least 10 minutes, LPR stops operating and the Video Rate Used increases to match the Video Rate.

If only LPR is enabled and the system detects packet loss, LPR attempts to clean the image but the video rate is not adjusted. If only Dynamic Bandwidth is enabled and the system detects packet loss of 3% or more, the video rate is adjusted but LPR does not clean the image.

You can view % Packet Loss, Video Rate, and Video Rate Used on the Call Statistics screen.

Configuring the System for Use with a Firewall or NAT

A firewall protects an organization's IP network by controlling data traffic from outside the network. Unless the firewall is designed to work with H.323 video conferencing equipment, you must configure the system and the firewall to allow video conferencing traffic to pass in and out of the network.

Network Address Translation (NAT) network environments use private internal IP addresses for devices within the network, while using one external IP address to allow devices on the LAN to communicate with other devices outside the LAN. If your system is connected to a LAN that uses a NAT, you will need to enter the **NAT Public (WAN) Address** so that your system can communicate outside the LAN.

To set up the system to work with a firewall or NAT:

- 1 In the web interface, go to **Admin Settings > Network > IP Network > Firewall**.
- 2 Configure these settings.

Setting	Description
Fixed Ports	<p>Lets you specify whether to define the TCP and UDP ports.</p> <ul style="list-style-type: none"> • If the firewall is not H.323 compatible, enable this setting. The RealPresence Group System assigns a range of ports starting with the TCP and UDP ports you specify. The system defaults to a range beginning with port 3230 for both TCP and UDP. <p>Note: You must open the corresponding ports in the firewall. You must also open the firewall's TCP port 1720 to allow H.323 traffic.</p> <ul style="list-style-type: none"> • If the firewall is H.323 compatible or the system is not behind a firewall, disable this setting. <p>For IP you need 2 TCP and 8 UDP ports per connection. For SIP you need TCP port 5060 and 8 UDP ports per connection.</p> <p>Note: Because RealPresence Group systems support ICE, the range of fixed UDP ports is 112. The RealPresence Group system cycles through the available ports from call to call. After the system restarts, the first call begins with the first port number, either 49152 or 3230. Subsequent calls start with the last port used, for example, the first call uses ports 3230 to 3236, the second call uses ports 3236 to 3242, the third call uses ports 3242 through 3248, and so on.</p>
TCP Ports UDP Ports	<p>Specifies the beginning value for the range of TCP and UDP ports used by the system. The system automatically sets the range of ports based on the beginning value you set.</p> <p>Note: You must also open the firewall's TCP port 1720 to allow H.323 traffic.</p>
Enable H.460 Firewall Traversal	<p>Allows the system to use H.460-based firewall traversal for IP calls. For more information, refer to H.460 NAT Firewall Traversal on page 37.</p>

Setting	Description
NAT	<p>Specifies whether the system should determine the NAT Public WAN Address automatically.</p> <ul style="list-style-type: none"> • If the system is not behind a NAT or is connected to the IP network through a Virtual Private Network (VPN), select Off. • If the system is behind a NAT that allows HTTP traffic, select Auto. • If the system is behind a NAT that does not allow HTTP traffic, select Manual.
NAT Public (WAN) Address	<p>Displays the address that callers from outside the LAN use to call your system. If you chose to configure the NAT manually, enter the NAT Public Address here.</p> <p>This field is editable only when NAT Configuration is set to Manual.</p>
NAT is H.323 Compatible	<p>Specifies that the system is behind a NAT that is capable of translating H.323 traffic.</p> <p>This field is visible only when NAT Configuration is set to Auto or Manual.</p>
Address Displayed in Global Directory	<p>Lets you choose whether to display this system's public or private address in the global directory.</p> <p>This field is visible only when NAT Configuration is set to Auto or Manual.</p>
Enable SIP Keep-Alive Messages	<p>Specifies whether to regularly transmit keep-alive messages on the SIP signaling channel and on all RTP sessions that are part of SIP calls. Keep-alive messages keep connections open through NAT/Firewall devices that are often used at the edges of both home and enterprise networks.</p> <p>When a RealPresence Group system system is deployed or registered in an Avaya SIP environment, Polycom recommends that you disable this setting to allow calls to connect fully.</p>

In environments set up behind a firewall, firewall administrators can choose to limit access to TCP connections only. Although TCP is an accurate and reliable method of data delivery that incorporates error-checking, it is not a fast method. For this reason, real-time media streams often use UDP, which

offers speed but not necessarily accuracy. Within an environment behind a firewall, where firewall administrator has restricted media access to TCP ports, calls can be completed using a TCP connection instead of UDP.



Systems deployed outside a firewall are potentially vulnerable to unauthorized access. Visit the Polycom Security section of the Knowledge Base at support.polycom.com for timely security information. You can also register to receive periodic email updates and advisories.

H.460 NAT Firewall Traversal

You can configure RealPresence Group systems to use standards-based H.460.18 and H.460.19 firewall traversal, which allows video systems to more easily establish IP connections across firewalls.

The following illustration shows how a service provider might provide H.460 firewall traversal between two enterprise locations. In this example the Polycom Video Border Proxy™ (VBP®) firewall traversal device is on the edge of the service provider network and facilitates IP calls between RealPresence Group systems behind different firewalls.

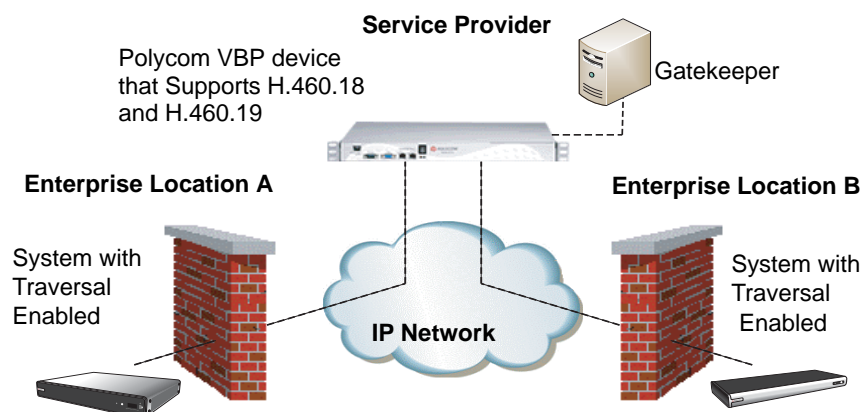

To use this traversal, RealPresence Group systems and firewalls must be configured as follows:

- 1 Enable firewall traversal on the RealPresence Group system.
 - a In the web interface, go to **Admin Settings > Network > IP Network > Firewall**.
 - b Select **Enable H.460 Firewall Traversal**.
- 2 Register the RealPresence Group system to an external Polycom VBP device that supports the H.460.18 and H.460.19 standards.
- 3 Make sure that firewalls being traversed allow RealPresence Group systems behind them to open outbound TCP and UDP connections.

- Firewalls with a stricter rule set should allow RealPresence Group systems to open at least the following outbound TCP and UDP ports: 1720 (TCP), 14085-15084 (TCP) and 1719 (UDP), 16386-25386 (UDP).
- Firewalls should permit inbound traffic to TCP and UDP ports that have been opened earlier in the outbound direction.

Basic Firewall/NAT Traversal Connectivity

Basic Firewall/NAT Traversal Connectivity allows RealPresence Group systems to connect to the SIP-based RealPresence solutions using the Acme Packet Net-Net family of Session Border Controllers (SBC). A RealPresence Group system connects to the Acme Packet Net-Net SBC as a remote enterprise endpoint. The remote enterprise endpoint is registered to the enterprise's SIP infrastructure and connects to an internal enterprise endpoint through the enterprise firewall.

For details about the use and configuration of the Acme Packet Net-Net SBC used in conjunction with this feature, refer to *Deploying Polycom Unified Communications in an Acme Packet Net-Net Enterprise Session Director Environment*.

RealPresence Group systems now also provide full mutual TLS support for SIP and XMPP Presence connections. Full mutual TLS support gives administrators the ability to identify and authenticate devices attempting to join conferences from outside the enterprise network.

Configuring Dialing Preferences

Dialing preferences help you manage the network bandwidth used for calls. You can specify the default and optional call settings for outgoing calls. You can also limit the call speeds of incoming calls.

To choose dialing preferences:

- 1 In the web interface, go to **Admin Settings > Network > Dialing Preference > Dialing Options** and **Admin Settings > Network > Dialing Preference > Preferred Speeds**.

2 Configure these settings.

Setting	Description
Enable H.239	Specifies standards-based People+Content data collaboration. Enable this option if you know that H.239 is supported by the far sites you will call.
Enable SIP	Allows the system to use SIP when connecting IP calls.
Video Dialing Order	Specifies how the system places video calls to directory entries that have more than one type of number. It also specifies how the system places video calls from the Place a Call screen when the call type selection is either unavailable or set to Auto . If a call attempt does not connect, the system tries to place the call using the next call type in the list.
Preferred Speed for Placing Calls IP Calls SIP (TIP) Calls	<p>Determines the speeds to use for IP or SIP (TIP) calls from this system when either of the following statements is true:</p> <ul style="list-style-type: none"> The call speed is set to Auto on the Place a Call screen The call is placed from the directory <p>If the far-site system does not support the selected speed, the system automatically negotiates a lower speed.</p> <p>Users cannot specify a call speed when placing calls from the Polycom Touch Control.</p> <p>The SIP (TIP) Calls setting is available only when the TIP setting is enabled.</p>
Maximum Speed for Receiving Calls IP Calls SIP (TIP) Calls	<p>Allows you to restrict the bandwidth used when receiving IP or SIP (TIP) calls.</p> <p>If the far site attempts to call the system at a higher speed than selected here, the call is renegotiated at the speed specified in this field.</p> <p>The SIP (TIP) Calls setting is available only when the TIP setting is enabled.</p>



For point-to-point calls, Polycom RealPresence Group 300 systems use a maximum of 3 Mbps of bandwidth and RealPresence Group 500 systems use a maximum of 6 Mbps.

Finding Your System's IP Address

You can find your RealPresence Group system's IP address in the local and the web interfaces:

- In the local interface, in **Administration > LAN Properties: IP Address**
- In the local interface, if the administrator has configured the system to show the IP address, at the top of the menu that is displayed when you press  with the remote control
- In the web interface, at the top of the page next to the language drop-down list and in **Admin Settings > Network > LAN Properties: Your IP Address is**

Monitors and Cameras

Connecting Monitors

Make sure that the system is powered off before you connect devices. For more information about connecting monitors to RealPresence Group systems, refer to [Appendix A](#), System Back Panel Views, on page 139.

Configuring Monitor Settings

The system constantly detects monitors connected to it. You have the choice to use or not use the monitor through the **Enable** setting.

To configure monitors:

- 1 In the web interface, go to **Admin Settings > Audio/Video > Monitors**.
- 2 Configure these settings on the Monitors page. The settings for Monitor 1, Monitor 2, and Monitor 3 are the same, although the available options can be different.

Setting	Description
Enable	Specifies the monitor setting: <ul style="list-style-type: none">• Auto – this is the default setting. Specifies that the Video Format and Resolution settings are automatically detected and disables those settings.• Manual – Enables you to select the Video Format and Resolution settings. Resolution settings are filtered based on the Video Format you selected.

Setting	Description
Video Format	<p>Specifies the monitor's format. Depending on which RealPresence Group System and monitor you configure, the choices are:</p> <ul style="list-style-type: none"> • HDMI • DVI • Component • VGA
Resolution	Specifies the resolution for the monitor.



Second monitors are available to Polycom RealPresence Group 300 systems with the monitor option key.

Maximizing Video Display on Your HDTV

When you use a television as your monitor, some of the HDTV's settings could interfere with the video display or quality of your calls. To avoid this potential problem, you should disable all audio enhancements in the HDTV menu, such as "SurroundSound."

In addition, many HDTVs have a low-latency mode called Game Mode, which could lower video and audio latency. Although Game Mode is typically turned off by default, you could have a better experience if you turn it on.

Finally, before attaching your Polycom RealPresence Group system to a TV monitor, ensure the monitor is configured to display all available pixels. This setting, also known as "fit to screen" or "dot by dot," enables the entire HD image to be displayed. The specific name of the monitor setting varies by manufacturer.

Using Sleep Settings to Prevent Monitor Burn-In

Monitors and Polycom RealPresence Group systems provide display settings to help prevent image burn-in. Plasma televisions can be particularly vulnerable to this problem. Refer to your monitor's documentation or manufacturer for specific recommendations and instructions. The following guidelines help prevent image burn-in:

- Ensure that static images are not displayed for long periods.
- Set the **Time before system goes to sleep** to 60 minutes or less.

- To keep the screen clear of static images during a call, disable the following settings:
 - **Display Icons in a Call** described on page [76](#)
 - **Show Time in Call** described on page [119](#)
- Be aware that meetings that last more than an hour without much movement can have the same effect as a static image.
- Consider decreasing the monitor's sharpness, brightness, and contrast settings if they are set to their maximum values.

Connecting Cameras

Polycom RealPresence Group systems provide inputs for multiple PTZ cameras.

Polycom RealPresence Group systems have built-in IR receivers to receive signals from the remote control. Be sure to point the remote control at the RealPresence Group system to control it.

For more information about connecting cameras to RealPresence Group systems, refer to [Appendix A, System Back Panel Views](#), on page 139.

Polycom EagleEye HD

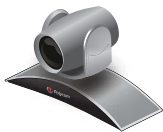

You can use the Polycom EagleEye HD camera with all 1080p-enabled Polycom RealPresence Group systems to send 1080p-encoded video when you have the 1080p Resolution option installed. You can also use the Polycom EagleEye HD camera with RealPresence Group systems that do not have the 1080p option, but you will be unable to receive 1080p encoded video.



When connecting a Polycom EagleEye HD camera to video input 2 on a Polycom RealPresence Group system, use only the approved Polycom UL Listed adaptor, Class 2 or LPS not exceeding 12 Volts, 3.33 Amps (part number 1465-52733-040). Verify the polarity of the power supply as shown on the Polycom camera next to the power supply input.

Polycom EagleEye 1080



You can use the Polycom EagleEye 1080 camera for RealPresence Group systems with the 1080p Resolution option installed to send 1080p video. You can also use the Polycom EagleEye 1080 camera with systems that do not have the 1080p Resolution option, to see local video in 1080 format.



When connecting a Polycom EagleEye 1080 camera to any input on a Polycom RealPresence Group system, use the cable and power supply that come with the camera. You must always use the power supply because the Polycom EagleEye 1080 camera does not receive power from the RealPresence Group system.

Polycom EagleEye View



The Polycom EagleEye View camera is a manual-focus, electronic pan, tilt, and zoom (EPTZ) camera that includes built-in stereo microphones and a privacy shutter. The Polycom EagleEye View camera is available with the Polycom RealPresence Group systems as the system camera and the main microphone. For more information about the Polycom EagleEye View microphones, refer to [Using the Polycom EagleEye View and EagleEye Acoustic Microphones](#) on page 58.



When connecting a Polycom EagleEye View camera, use the brown cable that comes with the camera if you want to use the camera's built-in microphones. Other cables might not carry the audio signals.

You can install the Polycom EagleEye View in a base-down orientation or inverted. To change the camera's orientation after installation, disconnect all cables attached to the camera. Then install the camera with the preferred orientation and reconnect the camera.

The Polycom EagleEye View camera can provide 1080i video to RealPresence Group systems.

Polycom EagleEye II

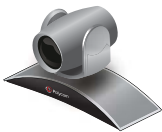

The Polycom EagleEye II camera can provide 720p 60/50 fps for Polycom RealPresence Group systems.

Polycom EagleEye III

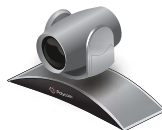

The Polycom EagleEye III camera can provide 1080i 60/50 fps, 1080p 60 fps, and 720p 60/50 fps resolutions on all Polycom RealPresence Group systems.

Polycom EagleEye Acoustic



The Polycom EagleEye Acoustic camera can provide 1080p 25/30 fps resolution with embedded image sensor processing (ISP) technology and has an auto focus lens system, two microphones for stereo audio pickup, an IR detector, a status LED, and a captured HDCI cord for connection to the system.

Polycom EagleEye Director



The Polycom EagleEye Director is a high-end automatic camera positioning system that works in conjunction with a Polycom RealPresence Group system to provide accurate close-up views of the person who is speaking. The EagleEye Director also provides smooth transitions between the close-up view of the person who is speaking and the room view.

The EagleEye Director uses a dual-camera system. While one camera tracks the person who is speaking, the other camera captures the room view. The EagleEye Director shows the room view while the camera moves from one speaker to another. When the tracking camera locates a person who is speaking, the EagleEye Director camera switches to a close-up of that person. By providing automatic and intelligent views in various speaking scenarios during a conference, the EagleEye Director delivers a user experience similar to a newscast video production.

Connecting Cameras to Polycom RealPresence Group Systems

Refer to your system's setup sheet and to the *Integrator's Reference Manual for the Polycom RealPresence Group Series* for connection details. Refer to the release notes for a list of supported PTZ cameras. If you connect a supported PTZ camera, the system detects the camera type and sets the appropriate configuration. Make sure that the system is powered off before you connect devices to it.



Do not connect more than one Polycom EagleEye Director to a single RealPresence Group system.

Configuring Video Input Settings

To configure camera and video settings in the web interface:

>> Go to **Admin Settings > Audio/Video > Video Inputs**.

Configuring General Camera Settings

Setting	Description
Allow Other Participants In a Call to Control Your Camera	Specifies whether other sites can adjust the view in your camera.
Power Frequency	Specifies the power line frequency for your system. In most cases, the system defaults to the correct power line frequency, based on the video standard used in the country where the system is located. This setting allows you to adapt the system in areas where the power line frequency does not match the video standard used. You might need to change this setting to avoid flicker from the fluorescent lights in your conference room.
Make This Camera Your Main Camera	Specifies which is the primary camera. You specify the main camera when you set up the system, but you can change that selection here.

Configuring Input Settings

Configure the following settings for each Input connected to your RealPresence Group system.



Settings that don't apply to the selected input are not displayed.

Setting	Description
Model	Displays the type of device using the input port.
Name	Displays the default name of the input, but you can enter your own name for the device.
Display as	Specifies whether the input is to be used for People or Content .
Input format	Specifies the source type of the device. This setting is read only unless the system does not detect the device.

Setting	Description
Optimized for	<p>Specifies Motion or Sharpness for the video input.</p> <ul style="list-style-type: none"> • Motion — This setting is for showing people or other video with motion. • Sharpness — The picture will be sharp and clear, but moderate to heavy motion at low call rates can cause some frames to be dropped. Sharpness is available in point-to-point H.263 and H.264 calls only. It is required for HD calls between 512 kbps and 2 Mbps.
Use Voices to Track People	<p>Specifies whether voice tracking is on or off.</p> <p>If camera tracking has not been calibrated, the setting is unavailable.</p> <p>This setting is available only when you have installed an EagleEye Director.</p>
Tracking Speed	<p>Determines how quickly the system finds someone new and switches to that person.</p> <p>This setting is available only when you have installed an EagleEye Director.</p>
Backlight Compensation	<p>Specifies whether to have the camera automatically adjust for a bright background. Backlight compensation is best used in situations where the subject appears darker than the background.</p> <p>Enabling this setting helps to relieve a bright background, which can impact the tracking performance of the Polycom EagleEye Director.</p>
White Balance	<p>Specifies whether to use the Auto or Manual setting to adjust neutral colors in the image.</p>
Brightness	<p>Provides a slider to adjust how bright the image is.</p> <p>This setting is unavailable if White Balance is set to Auto.</p>
Color Saturation	<p>Provides a slider to adjust how colorful the image is.</p> <p>This setting is unavailable if White Balance is set to Auto.</p>

Configuring the Polycom EagleEye Director

Use the remote control or web interface to configure the Polycom EagleEye Director. You cannot configure the EagleEye Director using the Polycom Touch Control.

Getting Started

Refer to *Setting up the Polycom EagleEye Director* for information about how to set up the EagleEye Director.

After setting up the EagleEye Director, follow these steps to get started:

1 Power on EagleEye Director.

You can verify that the device is detected and compatible with the RealPresence Group system's software on the System Status page. Do one of the following:

- In the local interface, go to **System > Status > EagleEye Director**.
- In the web interface, go to **Diagnostics > System > System Status > EagleEye Director**.

As long as you see **EagleEye Director** among the status settings, the device has been detected. You can select the **More Info** link to see whether the camera software is up to date. If the software is compatible with the RealPresence Group system software, you'll see a green dot. If the dot is red, you can select the **Adjust EagleEye Settings** link in the web interface to update the software as described in *Installing Software and Options for the Polycom RealPresence Group Series and Accessories*.

- 2** Calibrate the cameras. Refer to [Calibrating the EagleEye Director Cameras](#) on page 49 for instructions. If you notice that the speaker is not framed accurately, ensure that the vertical bar of the EagleEye Director is vertical. Placing the EagleEye Director on a horizontal surface can help to ensure that the vertical bar is vertical. You might also need to recalibrate the cameras.
- 3** Adjust the room view. Refer to [Adjusting the Room View](#) on page 49 for instructions.



Points to note when detecting the Polycom EagleEye Director

When the system first detects the EagleEye Director, a calibration wizard starts. If the EagleEye Director is not detected, try one of the following solutions:

- Ensure all cables are tightly plugged in and the ball stubs are tightly pressed into the hole on the base, then attempt camera detection again.
- If the EagleEye Director is powering on or waking up from sleep, wait a few seconds and then attempt to detect the camera again.
- Restart the RealPresence Group system.
- Manually power off the EagleEye Director by unplugging its power supply and unplugging the HDCI cable from the RealPresence Group system. Then power on the EagleEye Director, plug the HDCI cable into the RealPresence Group system, and attempt camera detection again.

Calibrating the EagleEye Director Cameras

- 1 Do one of the following:
 - In the local interface, go to **Administration > Camera Tracking > Calibration**.
 - In the web interface, go to **Admin Settings > Audio/Video > Video Inputs** and select **Camera Calibration**.
- 2 Follow the directions in the Auto Calibration page that appears. When you click **Start**, auto-calibration begins. When the automatic process ends, you have these choices:
 - **Yes, I see a green box around my mouth.** Selecting this choice means auto-calibration was successful and you can move forward with adjusting the room view, if you like.
 - **No, I see a green box, but it is not around my mouth.** Selecting this choice means you can try auto-calibration again or manually calibrate the camera.
 - **No, I do not see a box at all.** Selecting this choice means you must manually calibrate the camera.
- 3 If necessary, follow these steps to manually calibrate the camera:
 - a Use the arrow buttons and zoom controls on the remote control or web interface to zoom completely in, then aim the camera at your mouth.
 - b Select **Begin Calibration** or **Start** and follow the onscreen instructions until a message displays indicating successful calibration.



Ensure that only one person speaks while you are calibrating the cameras and keep the background quiet.

If you rearrange or move the Polycom EagleEye Director, recalibrate it.

If you cannot successfully calibrate the cameras, ensure that all seven EagleEye Director tracking microphones are working correctly. Five of those microphones are horizontal and two are vertical reference audio microphones. Calibration fails if any of the microphones do not work. For ways to test microphone functionality, refer to the **Camera Tracking** settings on page [127](#).

Adjusting the Room View

- 1 Do one of the following:
 - From the local interface, go to **Administrative > Camera Tracking > Calibration**, and then select **Begin Calibration**.
 - From the web interface, go to **Admin Settings > Audio/Video > Video Inputs**, and then select the **Input** used by the Polycom EagleEye Director.

- 2 Do one of the following:
 - In the local interface, select **Skip** to move to the Adjust Room View screen.
 - In the web interface, select **Adjust Room View**.
- 3 Use the arrow buttons and zoom controls on the remote control or web interface to show the room view you want far site participants to see.
- 4 Select **Finish** to save the settings and return to the Camera Settings screen.

Enabling and Disabling Camera Tracking with EagleEye Director

If EagleEye Director tracking is enabled, the camera follows the person or people who are speaking. This tracking action, also called automatic camera positioning, can be manually started or stopped.

To enable camera tracking:

- >> Do one of the following:
 - In the local interface, go to **Administration > Camera Tracking > Settings**.
 - >> For the **Tracking Mode** setting, select **Voice**.

This is the default tracking mode. In this mode, the camera automatically tracks the current speaker in the room using a voice tracking algorithm.

When you select the **Voice Tracking Mode**, you can also choose the **Tracking Speed**. This speed determines how quickly the camera moves to each person who speaks. The default speed is **Normal**.

If voice tracking does not work as expected, make sure the microphones are functioning properly. For ways to test microphone functionality, refer to the **Camera Tracking** settings on page [127](#).
 - In the web interface, go to **Admin Settings > Audio/Video > Video Inputs**, and then select the **Input** used by the Polycom EagleEye Director.
 - >> Enable the **Use Voices to Track People** setting.
 - If the RealPresence Group system is paired with a Polycom Touch Control, follow these steps:
 - 1 Touch **Cameras** on the Home screen or the Call screen.
 - 2 If the EagleEye Director is not currently selected, select it:

- a Touch **Select Cameras** and select the EagleEye Director camera.
 - b Touch **Control Camera**.
- 3 Select **Start Camera Tracking**.

To disable camera tracking:

>> Do one of the following:

- In the local interface, go to **Administration > Camera Tracking > Settings**.
 - >> For the **Tracking Mode** setting, select **Off**.
In this mode, the tracking function is disabled. You must manually move the camera using the remote control or the Polycom Touch Control.
- In the web interface, go to **Admin Settings > Audio/Video > Video Inputs**, and then select the **Input** used by the Polycom EagleEye Director.
 - >> Disable the **Use Voices to Track People** setting.
- If the RealPresence Group system is paired with a Polycom Touch Control, touch **Cameras** on the Home screen or the Call screen and select **Stop Camera Tracking**.

To start or stop camera tracking in the local interface:

>> When you are not in a call, go to **Menu > Cameras** and select **Enable Camera Tracking** or **Disable Camera Tracking**, as needed.

Camera tracking can also start or stop based on the following actions:

- Camera tracking starts automatically when you make a call.
- Camera tracking stops after you hang up a call.
- Camera tracking temporarily stops when you mute the RealPresence Group system in a call. It resumes when you unmute the system.



Tracking performance can be affected by room lighting. If the room is too bright for camera tracking to work properly, you can improve the tracking performance by adjusting the **Backlight Compensation** setting on the Cameras screen. To find this setting in the web interface, you can go to **Admin Settings > Audio/Video > Video Inputs > General Camera Settings**.

Configuring Camera Presets

Camera presets are stored camera positions that you can create in the local interface before or during a call.

Presets allow users to:

- Automatically point a camera at pre-defined locations in a room.
- Select a video source.

If your camera supports pan, tilt, and zoom movement, and it is set to People, you can create up to 10 preset camera positions for it using the remote control or keypad, or the Polycom Touch Control. Each preset stores the camera number, its zoom level, and the direction it points (if appropriate). Presets remain in effect until you delete or change them.

If far-site camera control is allowed, you can create 10 presets for the far-site camera. You can create up to 16 presets (0-15) for the far-site camera if your system is paired with a Polycom Touch Control. These presets are saved only for the duration of the call. You might also be able to use presets that were created at the far site to control the far-site camera.

If a Polycom Touch Control is paired with a Polycom RealPresence Group system, you must use the Polycom Touch Control to create presets. Refer to [Setting and Using Presets with the Polycom Touch Control](#) on page 53.



If you use a Polycom EagleEye Director with your RealPresence Group system, you cannot use presets for voice tracking.

Setting and Using Presets with the Remote Control or Keypad

To move the camera to a stored preset:

- 1 If you are in a call, press **Select** on the remote control to switch between a near-site (**Your Camera**) or far-site (**Their Camera**) camera.
- 2 Press a number on the remote control.

To view your presets:

>> From the menu, select **Cameras > Preset**.

Icons for presets 0-9 are shown on the screen. A snapshot above a number means that a preset has been assigned to that number. A gray box means that no present has been assigned to that number.

To store a preset using the remote control:

- 1 If you are in a call, press **Select** to choose Your or Their camera.
- 2 If you selected a camera that supports electronic pan, tilt, and zoom, you can adjust the camera's position:
 - Press **Zoom** to zoom the camera out or in.
 - Press the arrow buttons on the remote control to move the camera up, down, left, or right.
- 3 Press and hold a number to store the preset position.
Any existing preset stored at the number you enter is replaced.



You cannot delete a preset. Instead, overwrite an existing preset with the new camera position.

Setting and Using Presets with the Polycom Touch Control**To view presets or move the camera to a stored preset:**

- 1 From the Home screen or Call screen, touch **Cameras**.
- 2 If you are in a call, touch **Near** or **Far** to select the appropriate camera control.
- 3 Touch **View Presets**.
- 4 Icons for presets 0-9 are shown on the screen.
Solid preset icons indicate stored camera positions. Transparent icons indicate unassigned presets.
- 5 Touch a  number to go to a saved preset.

You can also view presets in the web interface by going to **Utilities > Tools > Monitoring**.

To store a preset:

- 1 From the Home screen or Call screen, touch **Cameras**.
- 2 If you are in a call, touch **Near** or **Far** to choose a near-end or far-end camera.
- 3 Touch **Select Camera** to choose a camera or other video source.
- 4 Touch **Control Camera** to move the camera to the desired position.
- 5 Touch **View Presets**, then touch and hold a number for 5 seconds to store the preset position. Any existing preset stored at the number you select is replaced.



A far-end camera preset can be stored only if the ability to control the far-end camera is enabled.

Experiencing High-Definition Video Conferencing

Polycom RealPresence Group systems offer the following high-definition (HD) capabilities:

- Send people or content video to the far site in HD
- Receive and display video from the far site in HD
- Display near-site video in HD
- Full-motion HD

Sending Video in High Definition

Polycom RealPresence Group systems with HD capability can send video in wide-screen, HD format. For information about frame rates for content, refer to [Chapter 5, Content](#), on page 71.

To send video in HD format, use any model of Polycom camera that supports HD video and a Polycom RealPresence Group system capable of sending 720p or better video.

Receiving and Displaying Video in High Definition

When the far site sends HD video, Polycom RealPresence Group systems with HD capability and an HD monitor can display the video in wide-screen, HD format. The HD 720 format supported by these systems is 1280 x 720, progressive scan format (720p). Polycom RealPresence Group systems with 1080 capability can receive 1080p progressive format and can display 1080p progressive or 1080i interlaced format.

Near-site video is displayed in HD format when you use an HD video source and an HD monitor. However, near-site video is displayed in SD if the system is in an SD or lower-resolution call.

**Requirements for an HD multipoint call:**

- The call must be hosted by a PolycomRealPresence Group system or a conferencing platform that supports HD such as Polycom RMX 1000 or Polycom RMX 2000.
- The Polycom RealPresence Group system host must have the appropriate options installed.
- All systems in the call must support HD (720p at 30 fps) and H.264.
- The call rate must be high enough to support HD resolution, as shown in [Appendix B, Call Speeds and Resolutions](#), on page 145.
- The call cannot be cascaded.

For more information about multipoint calls, refer to [Configuring Multipoint Calling](#) on page 77.

Using Full-Motion HD

With RealPresence Group Series systems, Polycom sets a higher bar for video and audio performance. Seeing participants in full 1080p 60 fps, or full-motion HD, brings video to a new level of realism. Full-motion HD provides those clear, vibrant visuals and flawless audio that are critical to replicating an “in the same room” experience.

In group collaboration, the quality of content is as important as the quality of the people on video. Content that is grainy, pixelated, or slow to update makes it hard to get the most out of your meetings. With Polycom RealPresence Group systems, you share full-motion HD people and content at the same time, which helps eliminate compromises when sharing across distances.

Microphones and Speakers

Connecting Audio Input

Make sure that the system is powered off before you connect devices to it.

To pick up audio from your site, you must connect a microphone to the Polycom RealPresence Group systems. Refer to your system's setup sheet for connection details.

For more information about connecting audio inputs to RealPresence Group systems, refer to [Appendix A](#), System Back Panel Views, on page 139.

Connecting Polycom RealPresence Group System Table or Ceiling Microphone Arrays

Polycom microphone arrays contain three microphone elements for 360° coverage. You can connect multiple Polycom microphone arrays to a Polycom RealPresence Group system.

For the best audio experience, do the following:

- Place the microphone array on a hard, flat surface (table, wall, or ceiling) away from obstructions, so the sound will be directed into the microphone elements properly.
- Place the microphone array near the people closest to the monitor.
- In large conference rooms, consider using more than one microphone array. Each Polycom microphone array covers a 3-6 foot radius, depending on the noise level and acoustics in the room.

Using the Polycom EagleEye View and EagleEye Acoustic Microphones

Polycom EagleEye View and EagleEye Acoustic cameras include built-in stereo microphones. The following tips can help you achieve the best audio when using these cameras:

- Enable Polycom StereoSurround.
- Place the camera at least 1 foot away from any walls to minimize boundary effects.
- Ensure that the people speaking are no more than 7 feet away from the EagleEye View or EagleEye Acoustic camera. The maximum distance covered depends on the noise level and acoustics in the room. If you connect a Polycom microphone, Polycom SoundStation®, or Polycom SoundStructure® to the RealPresence Group system's microphone input while an EagleEye View or EagleEye Acoustic camera is connected to the system, the camera's built-in microphones are automatically disabled.
- Polycom recommends connecting other audio input devices in conference rooms larger than 12 feet by 15 feet.

Connecting a Polycom SoundStation IP 7000 Phone

When you connect a Polycom SoundStation IP 7000 conference phone to a Polycom RealPresence Group system, the conference phone becomes another way to dial audio or video calls. The conference phone also operates as a microphone, and as a speaker in audio-only calls. For more information, refer to the following documents on the Polycom web site:

- *Integration Guide for the Polycom SoundStation IP 7000 Conference Phone Connected to a Polycom RealPresence Group System in Unsupported VoIP Environments*
- *User Guide for the Polycom SoundStation IP 7000 Phone Connected to a Polycom RealPresence Group System in Unsupported VoIP Environments*

Connecting Devices to the Polycom RealPresence Group 300 and RealPresence Group 500 Microphone Inputs

RealPresence Group 300 and RealPresence Group 500 systems can support any of the following devices:

- Two RealPresence Group microphone arrays or two Polycom HDX microphone arrays
- One SoundStation IP 7000 phone and one RealPresence Group or Polycom HDX microphone array
- One SoundStructure C-Series device and up to four RealPresence Group or Polycom HDX microphone arrays
- Polycom EagleEye View or EagleEye Director with microphones enabled

Connecting Devices to the Polycom RealPresence Group 700 Microphone Input

RealPresence Group 700 systems can support any of the following devices:

- Three Polycom RealPresence Group microphone arrays or three Polycom HDX microphone arrays
- One SoundStation IP 7000 phone and two RealPresence Group or Polycom HDX microphone arrays
- One SoundStructure C-Series device and up to four RealPresence Group or Polycom HDX microphone arrays
- Polycom EagleEye View or EagleEye Director with microphones enabled



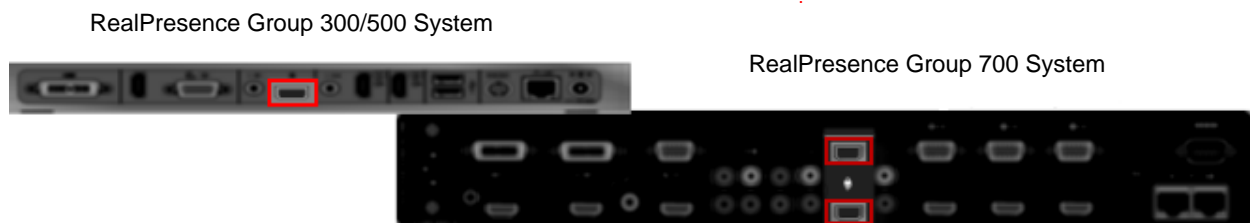



As shown in the following diagram, The RealPresence Group 300 and RealPresence Group 500 systems have one microphone input, while the RealPresence Group 700 system has two. You can freely configure the way you connect devices to the system, as long as you do not exceed the limits mentioned in the previous sections. If you are using the RealPresence Group 700 system, you can connect devices to either or both inputs as long as you stay within the guidelines for the total number of devices allowed for the system.



For information about cables, refer to the *Integrator's Reference Manual for the Polycom RealPresence Group Series*.

Placing Polycom Microphones to Send Stereo from Your Site

The following illustrations show microphone placement examples for different room layouts.

Number of Microphones with Stereo Enabled	Long Table	Wide Table
One	Mic 1 set to Left+Right 	Mic 1 set to Left+Right 
Two	Mic 1 set to Left+Right Mic 2 set to Left+Right 	Mic 1 set to Left Mic 2 set to Right 
Three	Mic 1 set to Left+Right Mic 2 set to Left+Right Mic 3 set to Left+Right 	Mic 1 set to Left Mic 2 set to Left+Right Mic 3 set to Right 
X – Not Used ○ – Left Channel ● – Right Channel		

Left and right channel assignments depend on the settings that you select on the Stereo Settings screen. If Autorotation is enabled for a microphone, the system automatically assigns active channels for the microphone. Make sure that microphones with Autorotation disabled are oriented as shown in the following illustration.



After you place the microphones, you will need to configure the system to send stereo as described in [Stereo Settings](#) on page 67.

Polycom Microphone Lights

The following table describes the behavior of the microphone lights on a Polycom table microphone.

Microphone Light	Status
Off	Not in a call
Green	In a call, mute off
Red	Mute on
Blinking Red	Configuration error occurred, such as exceeding the number of supported conference link devices
Amber	Firmware upload

Connecting Non-Polycom Microphones or a Mixer to a Polycom RealPresence Group System

You can connect non-Polycom microphones directly to audio input 1 on a Polycom RealPresence Group system system, or through a line-level mixer to the AUX audio input on any Polycom RealPresence Group system system. For more information about configuring these non-Polycom microphones, refer to [Settings for Non-Polycom Microphones](#) on page 69.

You can connect several microphones to a Polycom RealPresence Group system through a Polycom audio mixer. The SoundStructure C-Series mixer connects to the digital microphone connector on a Polycom RealPresence Group system, and no configuration is necessary.

Connecting a Polycom audio mixer to Polycom RealPresence Group systems provides flexibility in audio setup. For example, it allows you to provide a microphone for each call participant in a boardroom. Refer to the *Integrator's Reference Manual for the Polycom RealPresence Group Series* for connection details.



Points to note about the SoundStructure digital mixer:

- Connect a SoundStructure digital mixer using the digital microphone input on the Polycom RealPresence Group system.
- Adjusting the volume on a Polycom RealPresence Group system changes the volume of the SoundStructure digital mixer that is connected.
- The following configuration settings are not available on a Polycom RealPresence Group system when a SoundStructure digital mixer is connected: Audio input 1 (Line In), Bass, Treble, Enable Polycom Microphones, Enable MusicMode, and Enable Keyboard Noise Reduction.
- The Polycom RealPresence Group system Line Output is muted when a SoundStructure digital mixer is connected.
- All echo cancellation is performed by the SoundStructure digital mixer.

Connecting Audio Output

You must connect at least one speaker to the Polycom RealPresence Group systems in order to hear audio. You can use the speakers built into the main monitor, or you can connect an external speaker system such as the Polycom StereoSurround kit to provide more volume and richer sound in large rooms.

When you connect a SoundStation IP 7000 conference phone to a Polycom RealPresence Group system, the conference phone becomes another way to dial audio or video calls. The conference phone also operates as a microphone, and as a speaker in audio-only calls.

Refer to your system's setup sheet for connection details. Make sure that the system is powered off before you connect devices to it.

For more information about connecting speakers to RealPresence Group systems, refer to [Appendix A, System Back Panel Views](#), on page 139.

Placing Speakers to Play Stereo from Far Sites

The Polycom StereoSurround kit is designed for use with Polycom RealPresence Group systems. It includes two speakers and a subwoofer.

When you set up the system for StereoSurround, the left microphone and speaker should be on the left from the local room perspective. Place the speaker connected to the audio system's right channel on the right side of the

system, and the other speaker on the left side. The system reverses the left and right channels for the far site, as shown in the following illustration. This ensures that the sound comes from the appropriate side of the room.

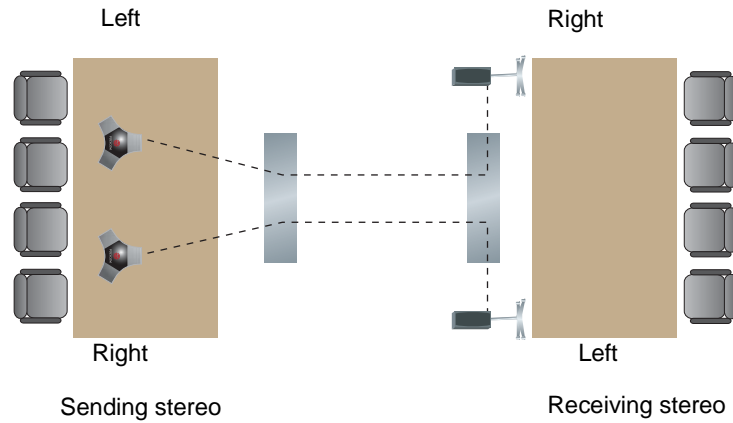

For best results, place the speakers about 60° apart as seen from the center of the conference table.

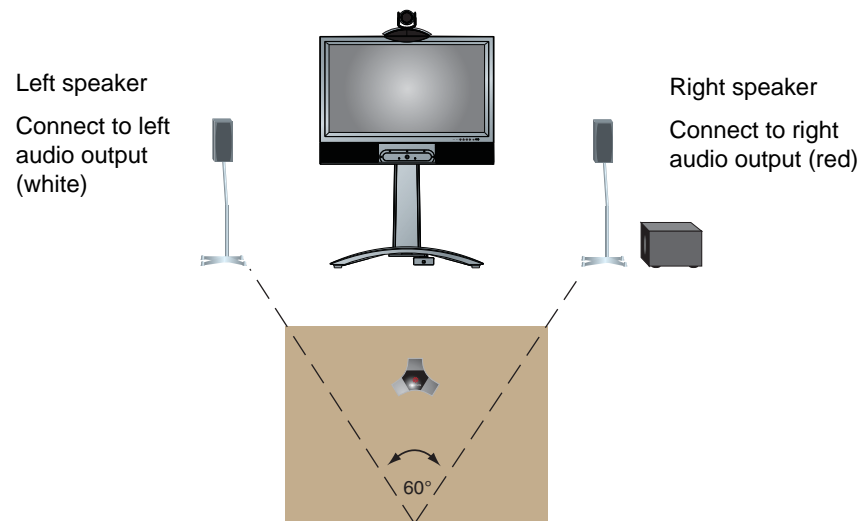

If you use the subwoofer in the Polycom StereoSurround kit, place it beside a wall or in a corner near the speakers.

Setting the Speaker Volume

To set the volume of an external speaker system:

- 1 Do one of the following:
 - In the local interface, go to **System > Diagnostics > Speaker Test**.
 - In the web interface, go to **Diagnostics > Audio and Video Tests > Speaker Test**.
- 2 Click **Start** to start the speaker test.
- 3 Adjust the volume of the speaker system. From the center of the room the test tone should be as loud as a person speaking loudly, about 80-90 dBA on a sound pressure level meter.
- 4 Click **Stop** to stop the speaker test.

Configuring Audio Settings

To configure the audio settings:

- 1 In the web interface, go to **Admin Settings > Audio/Video > Audio**.
- 2 Configure the settings for each section of the Audio screen that are described in this section of the book.



Some audio settings are unavailable when a SoundStructure digital mixer is connected to the Polycom RealPresence Group system. For more information, refer to [Connecting Non-Polycom Microphones or a Mixer to a Polycom RealPresence Group System](#) on page 61.

General Audio Settings

Setting	Description
Polycom StereoSurround	<p>Specifies that Polycom StereoSurround is used for all calls.</p> <p>To send or receive stereo audio, make sure your Polycom RealPresence Group system is set up as described in Connecting Devices to the Polycom RealPresence Group 300 and RealPresence Group 500 Microphone Inputs on page 59 and Connecting Audio Output on page 62.</p>
Sound Effects Volume	Sets the volume level of the ring tone and user alert tones.
Ringtone	Specifies the ring tone used for incoming calls.
Alert Ringtone	Specifies the tone used for user alerts.
Mute Auto Answer Calls	<p>Specifies whether to mute incoming calls.</p> <p>Incoming calls are muted by default until you press the mute button on the microphone or on the remote control.</p>
Enable MusicMode	<p>Specifies whether the system transmits audio using a configuration that best reproduces live music picked up by microphones.</p> <p>Note: Noise suppression, automatic gain control, and keyboard noise reduction are disabled when this setting is enabled.</p>
Keyboard Noise Reduction	<p>Specifies whether the system mutes audio from any site when keyboard tapping sounds are detected but no one is talking at that site.</p> <p>Note: MusicMode is disabled when this setting is enabled. Keyboard Noise Reduction is not available if an audio mixer is used.</p>
Enable Polycom Microphones	Specifies whether the Polycom microphones are enabled.

Audio Input

Setting	Description
Use 3.5 mm Input for Microphone	<p>Specifies whether content audio input is to be treated like a microphone and follow all the standard rules of a microphone input.</p> <p>Selecting this setting means that the microphone plugged into the 3.5 mm jack on the back of the system provides line-level audio and has its own power source, such as a wireless microphone receiver.</p>
Echo Canceller	<p>Specifies whether to use the system's built-in echo canceller with the 3.5 mm audio input.</p> <p>This setting is visible only when the Use 3.5 mm Input for Microphone setting is enabled.</p>
3.5 mm Level	Specifies the audio level control for the 3.5 mm input port.
3.5 mm	Displays the audio level meter for the 3.5 mm input port of a Polycom RealPresence Group 500 system.
HDMI Input Level	Specifies the audio level control for the HDMI input port.
HDMI Input	Displays the audio level meter for the HDMI input port of a Polycom RealPresence Group 300 or RealPresence Group 500 system.

Audio Output

Setting	Description
Line Output Mode	<p>Specifies whether volume for a device connected to the line out connectors is variable or fixed.</p> <ul style="list-style-type: none"> • Variable—Allows users to set the volume with the remote control. • Fixed—Sets the volume to the Audio Level specified in the system interface.
Line Output Level	Displays the output level meter for line output 1.
Master Audio Volume	Sets the main audio output volume level going to the speakers.

Bass	Sets the volume level for the low frequencies without changing the master audio volume.
Treble	Sets the volume level for the high frequencies without changing the master audio volume.

Stereo Settings

To send or receive stereo audio, make sure your Polycom RealPresence Group system equipment is set up as described in [Connecting Devices to the Polycom RealPresence Group 300 and RealPresence Group 500 Microphone Inputs](#) on page 59 and [Connecting Audio Output](#) on page 62. Then configure the system to use Polycom StereoSurround, test the system configuration, and place a test call.

If you are in a call with a far site that is sending audio in stereo mode, you can receive in stereo. In multipoint calls where some sites can send and receive stereo and some sites cannot, any site that is set up to send or receive stereo will be able to do so.



Some audio settings are unavailable when a SoundStructure digital mixer is connected to the Polycom RealPresence Group system

Setting	Description
Polycom Microphone Type	Displays the type of Polycom microphone being used.
Stereo	Positions the audio input within the left and right channels. Left sends all of the audio to the left channel. Right sends all of the audio to the right channel. For Polycom digital microphone and ceiling microphone arrays, Left+Right sends audio from one microphone element to the left channel and audio from a second element to the right channel.
Autorotation	Specifies whether autorotation is used for Polycom microphones. If this feature is enabled, the system automatically assigns left and right channels for the microphone based on sound it senses from the left and right speakers. Note: This feature does not work when headphones are used.
Audio Meter (dB meter)	Lets you see the peak input signal level for Polycom microphones.

Audio Meters

The audio meters in the user interface allow you to identify left and right channels. The meters also indicate peak signal levels. Set signal levels so that you see peaks between +3 dB and +7 dB with normal speech and program material. Occasional peaks of +12 dB to +16 dB with loud transient noises are acceptable. If you see +20 on the audio meter, the audio signal is 0 dBFS and the audio might be distorted.

Testing StereoSurround

After you configure the system to use Polycom StereoSurround, test the system configuration and place a test call.

To test your stereo configuration:

- 1 Make sure the microphones are positioned correctly.
Refer to [Placing Polycom Microphones to Send Stereo from Your Site](#) on page 60.
- 2 In the web interface, go to **Admin Settings > Audio/Video > Audio**.
- 3 Gently blow on the left leg and right leg of each Polycom microphone while watching the bar meters to identify the left and right inputs.
- 4 Test the speakers to check volume and verify that audio cables are connected. If the system is in a call, the far site hears the tone.

Exchange the right and left speakers if they are reversed.

Adjust the volume control on your external audio amplifier so that the test tone sounds as loud as a person speaking in the room. If you use a Sound Pressure Level (SPL) meter, it should measure about 80-90 dBA in the middle of the room.

To make a test call in stereo using the local interface, web interface, or remote control:

- >> Do one of the following:
- Select **Polycom Austin Stereo** from the directory Sample Sites group in the local or web interface.
 - Enter `stereo.polycom.com` in the dialing field and press  on the remote control.

To make a test call in stereo using the Polycom Touch Control:

- 1 From the Polycom Touch Control Home screen, touch **Place a Call**.
- 2 Touch **Favorites**.

3 Select **Polycom Austin Stereo**.

The Polycom Austin Stereo site demonstrates the stereo feature with an entertaining and informative presentation.

Settings for Non-Polycom Microphones

To configure a Polycom RealPresence Group system to use devices connected directly to audio input 1:

- 1** In the web interface, go to **Admin Settings > Audio/Video > Audio > Audio Input**.
- 2** Do the following:
 - a** Enable **Use 3.5 mm Input for Microphone**.
 - b** Enable **Echo Canceller**.
 - c** Adjust the **3.5 mm Level** if necessary.
 - d** Speak into the microphones that are connected to the audio line inputs. The audio meter should peak at about 5 dB for normal speech.

Content

You can present content during calls when you use sources such as the following:

- A VCR or DVD player connected directly to a video input on a Polycom RealPresence Group system
- People+Content IP installed on a computer, with any Polycom RealPresence Group system
- A computer connected directly to a Polycom RealPresence Group system or a Polycom Touch Control
- A USB drive connected to a Polycom Touch Control

Polycom RealPresence Group systems achieve maximum content frame rate of 30 fps for 1080p with a 1080p Resolution option key installed, and 60 fps for 720p. If you use **Content** as the **Quality Preference** in your network IP settings, you can achieve a content frame rate of 60 fps for 1080p with the 1080p Resolution option key installed.

For more information about sharing content during a call, refer to the *User's Guide for the Polycom RealPresence Group Series*.

Configuring VCR/DVD Player Settings

With a Polycom RealPresence Group 500 system, you can connect a VCR or DVD/Blu ray player to an HDMI or VGA input to play content

With a Polycom RealPresence Group 700 system, you can also connect a VCR or DVD/Blu ray player to the system's VCR input to play videotapes or DVDs in calls.



Using a VCR or DVD player with a RealPresence Group 300 system is not a viable option.

Playing a Videotape or DVD

The VCR/DVD inputs are active when you select the camera source configured as VCR. The microphone inputs remain active while the VCR or DVD player is playing. Call participants might want to mute the microphones while playing videotapes or DVDs.

To configure VCR/DVD audio settings for playing a videotape or DVD:

- 1 In the web interface, go to **Admin Settings > Audio/Video > Audio > Audio Input**.
- 2 Set **Line In Level** for playback volume of the VCR/DVD player relative to other audio from the system.
- 3 Enable **VCR/DVD Audio Out Always On** unless you have the VCR/DVD inputs and outputs both connected to the same device to play and record.

Connecting Computers to Polycom RealPresence Group Systems

You can connect a computer directly to a Polycom RealPresence Group system. When you do this, other call participants can see everything that you see on your computer.

When you connect to video and audio from your computer, the audio is muted unless the computer is selected as a video source.

For more information about connecting computers as content video sources for Polycom RealPresence Group systems, refer to [Connecting Cameras](#) on page 43. Refer to your system's setup sheet for connection details.

Configuring Content Sharing

To configure the content display:

- 1 In the web interface, go to **Admin Settings > Audio/Video > Video Inputs** and select the input you want to configure for Content.
- 2 For the **Display as** setting, select **Content** for the input that will display content.

When you connect a content-sharing device such as a laptop to the input, the content starts displaying. If the content-sharing device is already connected, you must manually show the content from the local interface. For more information about showing content, refer to the *User's Guide for the Polycom RealPresence Group Series*.

As long as the default values for other settings in the system have not changed, you are ready to share content on your RealPresence Group system. However, if you disabled the H.239 protocol for some reason, you must enable the program for content sharing by following these steps:

- 1 In the web interface, go to **Admin Settings > Network > Dialing Preference**.
- 2 Enable **H.239**.



You cannot enable or disable H.239 while in a call.

If the audio level of the call using content sharing needs to be adjusted, follow these steps to change the level:

- 1 In the web interface, go to **Admin Settings > Audio/Video > Audio > Audio Input**.
- 2 Set the **Audio Input Level**.

Configuring Content Display with People+Content IP

People+Content IP enables a presenter to show content from a computer to other sites in a video conference using only an IP network connection. The presenter can show PowerPoint® slides, video clips, spreadsheets, or any other type of content from a computer. People+Content IP supports any computer desktop resolution with color set to 16-bit or higher.

Before a presenter can use a computer to show content with People+Content IP, you need to:

- Download the People+Content IP software application from the Polycom web site to the computer or computers that the presenter will use to show content.

You don't need to change the computer resolutions and you don't need special cables or hardware, but each computer must meet these requirements:

- Operating System: Windows 7
- Minimum computer: 500 MHz Pentium® III (or equivalent); 256 MB memory
Recommended computer: 1 GHz Pentium III (or equivalent); 512 MB memory
- Connect the computer or computers to the IP network.

To install People+Content IP on a computer:

- 1 On a computer, open a web browser and go to the Polycom web site at www.polycom.com/ppcip.
- 2 Download and install the People+Content IP software.



If the Polycom RealPresence Group system is paired with a Polycom Touch Control, People+Content IP does not need to be installed. If you connect the PC to the USB connection on the underside of the Polycom Touch Control, a version of People+Content IP launches automatically.

Placing and Answering Calls

Configuring System Settings

The System Settings screens provide access to high-level options for the entire system. For convenience, some of the User Settings options are repeated on these screens.

To configure a system name:

- 1 In the web interface, go to **Admin Settings > General Settings > System Settings > System Name**.



The first character of a System Name must be a letter or a number. The System Name cannot begin with the dollar sign (\$) or underscore (_) character.

- 2 In the **System Name** field, enter a name and click **Save**.
This name appears on the screen for the far site when you are making calls.

Configuring Call Settings

The call settings screen allows you to determine which settings are available to users when they place and answer calls in both the web interface and the local interface.

To configure call settings:

- 1** In the web interface, go to **Admin Settings > General Settings > System Settings > Call Settings**.
- 2** Configure these settings.

Setting	Description
Maximum Time in Call	<p>Enter the maximum number of hours allowed for call length.</p> <p>When that time has expired, you see a message asking you if you want to hang up or stay in the call. If you do not answer within one minute, the call automatically disconnects. If you choose to stay in the call at this time, you will not be prompted again.</p> <p>Selecting Off removes any limit.</p> <p>This setting also applies when you are viewing the Near video screen or showing content, even if you are not in a call. If the maximum time is reached while viewing Near video, the system automatically returns to the Home screen. If content is being shown, the content stops.</p>
Auto Answer Point-to-Point Video	<p>Sets the answer mode for calls with one site. This setting specifies whether to answer incoming point-to-point calls automatically.</p>
Auto Answer Multipoint Video	<p>Sets the answer mode for calls with two or more other sites. This setting specifies whether to answer incoming multipoint calls automatically. Available only when the system has multipoint capability.</p>
Display Icons in a Call	<p>Specifies whether to display all on-screen graphics, including icons and help text, during calls.</p>

- 3** To save your changes, click **Save**.

Setting the Call Answering Mode

To set the call answering mode:

- 1 In the web interface, go to **Admin Settings > General Settings > System Settings > Call Settings**.
- 2 Select **Auto Answer Point-to-Point Video** to set the answer mode for calls with one site, or select **Auto Answer Multipoint Video** to set the mode for calls with two or more other sites, and then select one of the following:
 - **Yes** – Answers calls automatically.
 - **No** – Enables you to answer calls manually.

Configuring Multipoint Calling

You can use your Polycom RealPresence Group system to participate in multipoint conferences. Multipoint conferences include multiple video sites and can also include H.323 audio-only or SIP audio-only sites. All H.323 audio-only and SIP audio-only connections count toward the number of sites in a call. Multipoint calls require a multipoint conferencing unit (MCU) or a hosting system. Depending on the system's configuration, Polycom RealPresence Group systems can host multipoint calls.

Entering a Multipoint Option Key

Depending on your Polycom RealPresence Group system model, you might need to enter a multipoint option key to enable multipoint calling. For information about purchasing a multipoint call option, please contact your Polycom distributor.

To enter the multipoint option key:

- 1 In the web interface, go to **Admin Settings > General Settings > Options**.
- 2 In the **Key** field, enter the Multipoint Video Conferencing option key.
- 3 Click **Save**.



The MP option key cannot be used with Polycom RealPresence Group 300 systems.

Including Multiple Sites in a Cascaded Call

You can include multiple sites in a cascaded call if the sites you call have internal multipoint capability. The following diagram shows how to do this.

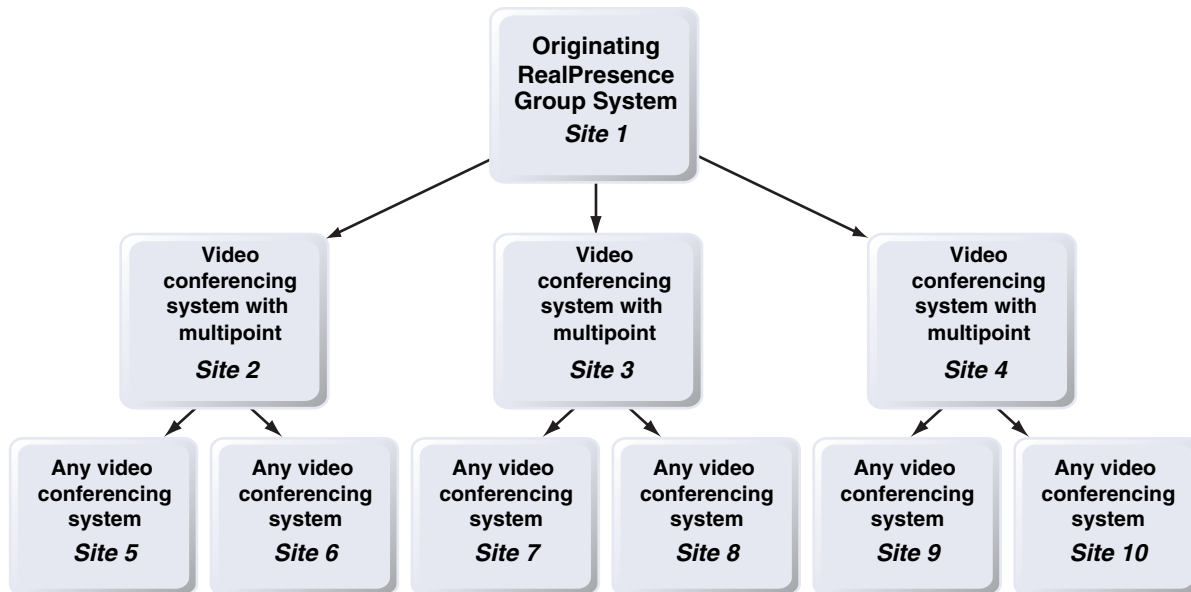

To place a cascaded call:

- 1 Create and call a group in the directory, or place calls one at a time to several other sites.
- 2 Ask each far site to call additional sites. Along with these additional sites, each far site in the original multipoint call can add one audio-only connection.



Points to note about cascaded calls:

- H.239 is not supported in cascaded calls.
- Cascaded multipoint is not supported in SIP calls.
- HD and SD multipoint are not supported when the Polycom RealPresence Group system hosts a cascaded call.
- Only Full Screen multipoint mode is available in cascaded calls.
- The encryption padlock icon might not accurately indicate whether a cascaded call is encrypted.

Managing Directories with the Polycom RealPresence Group System Web Interface

Directory Group Overview

Having groups in the directory can help users find calling information quickly and easily. Polycom RealPresence Group systems support global groups and Favorites groups.

Polycom RealPresence Group systems support up to 2,000 Favorites that users create within Favorites. They can also support one of the following:

- Up to 200 additional contacts with presence, which appear in Favorites, when registered with Microsoft Office Communications Server 2007 R2 or Microsoft Lync Server 2010.
- Up to 200 additional contacts with presence, which appear in Favorites, when registered with Polycom CMA.
- Up to 4,000 contacts from a Polycom GDS server.
- An unlimited number of contacts when the RealPresence Group system is registered with Microsoft Office Communications Server 2007 R2 or Microsoft Lync Server 2010.

Polycom RealPresence Group systems support up to 200 Favorites groups that users create within Favorites. If the system is connected to a global directory server, it can also support one of the following:

- Up to 64 additional groups from the Microsoft Office Communications Server or Microsoft Lync Server, which appear in the Favorites group.
- Up to 200 additional distribution groups from Polycom CMA, which appear in the Global Directory group.

Global Directory Entries

Global directory entries are assigned to a global group with the name that you specify in the Directory Server configuration. Up to 200 search results can be displayed at a time from an LDAP or Microsoft global directory. Users cannot edit or delete global directory entries or global directory groups.

Managing Favorites

Local interface users can select **Contacts** from the menu to view favorites and the directory.

Web interface users can add favorites from the directory, create new favorite contacts, and create favorite groups.

You perform the following tasks on the **Home > Manage Favorites** screen.

To create a new Favorites contact

- 1 To create a favorite contact not in the directory list, click **Create New Favorite**.
- 2 Enter the contact call information and click **Save**.

To create a Favorites group

- 1 Click **Create New Group**.
- 2 Enter a **Display Name** for the group and click **Save**.
A success message is displayed.
- 3 To add contacts to the group, click **Add Contacts** on the success message.
- 4 Enter a contact name in the search box and click **Search**.
- 5 In the entry you want to add to the group, click **Add**.
- 6 Repeat the above steps to add more contacts to the group.
- 7 Click **Done**.

To edit a Favorites group

- 1 Find the group name in the list of contacts.
- 2 Next to the group contact name, click **Edit Group**.
Do one of the following:
 - To add contacts to the group, click **Add From Directory**, enter a contact name, click **Search**, and then **Add** to add a contact.
 - To remove contacts from the group, select a contact name and click **Remove**.
- 3 Repeat the above steps to continue adding or removing contacts.
- 4 Click **Done**.

To delete a Favorites contact or group

- 1 In the search box, type a contact name and click **Search**.
- 2 In the contact name you want to delete, click **Delete**.

Types of Favorites Contacts

Favorites contains the types of Contacts shown in the following table.

Directory Server Registration	Types of Contacts	Presence State Displayed
Polycom GDS	<ul style="list-style-type: none"> Directory entries created locally by the user. 	Unknown
	<ul style="list-style-type: none"> References to Polycom GDS entries added to Favorites by the user. <p>These entries are available only if the system is successfully registered with Polycom GDS. Users can delete these entries from Favorites. Users can copy these entries to other Favorites and remove them from those groups. Users cannot edit these entries.</p>	Online/Offline
LDAP with H.350 or Active Directory	<ul style="list-style-type: none"> Directory entries created locally by the user References to LDAP directory entries added to Favorites by the user. <p>These entries are available only if the system can successfully access the LDAP/Active Directory server. Users can delete these entries from Favorites. Users can copy these entries to other Favorites and remove them from those groups. Users cannot edit these entries.</p>	Unknown
LDAP by a Polycom CMA System	<ul style="list-style-type: none"> Directory entries created locally by the user. References to LDAP directory entries added to Favorites by the user. <p>These entries are available only if the system can successfully access Polycom CMA. Users can delete these entries from Favorites. Users can copy these entries to other Favorites and remove them from those groups. Users cannot edit these entries.</p>	Unknown
	<ul style="list-style-type: none"> LDAP directory entries saved as Favorites by the user and stored with the presence service. <p>Users can delete these entries from Favorites. Users can copy these entries to other Favorites and remove them from those groups. Users cannot edit these entries.</p>	Real-time presence

Directory Server Registration	Types of Contacts	Presence State Displayed
Microsoft	<ul style="list-style-type: none"> Microsoft Office Communications Server or Microsoft Lync Server directory entries saved as Contacts by the user in Office Communicator and stored on the Microsoft Office Communications Server or Microsoft Lync Server. <p>Users must create their contact lists using Microsoft Office Communicator on a computer. Users cannot edit or delete these entries from Favorites using the Polycom RealPresence Group system. Users can copy these entries to other Favorites and remove them from those groups.</p>	Real-time presence

Connecting to Microsoft Exchange Server Calendaring Service

Polycom RealPresence Group systems can connect to Microsoft Exchange Server 2007 or 2010 and retrieve calendar information. Connecting to a calendaring service allows the system to:

- Display the day's scheduled meetings, along with details about each.
- Hide or show details about meetings marked Private, depending on the configuration of the system.
- Display a meeting reminder before each scheduled meeting, along with a reminder tone.

To configure Calendaring properties:

- 1 In the web interface, go to **Admin Settings > Servers > Calendaring Service**.
- 2 Configure these settings.

Setting	Description
Enable Calendaring Service	Enables the system to connect to the Microsoft Exchange Server 2007 or 2010 or and retrieve calendar information.
Microsoft Exchange Server	Specifies the Fully Qualified Domain Name (FQDN) of the Microsoft Exchange Client Access Server. If your organization has multiple Client Access Servers behind a network load balancer, then this is the FQDN of the server's Virtual IP Address. If required, an IP address can be used instead of an FQDN, but Polycom recommends using the same FQDN that is used for Outlook clients.
Domain	Specifies the domain for registering to the Microsoft Exchange Server 2007 or 2010, in either NETBIOS or DNS notation, for example, either <code>company.local</code> or <code>COMPANY</code> .
User Name	Specifies the user name for registering to the Microsoft Exchange Server 2007 or 2010, with no domain information included. This can be the system's name or an individual's name.
Password	Specifies the system's password for registering with the Microsoft Exchange Server 2007 or 2010.
Email	Specifies the Outlook email address this system should monitor for calendar information. This should match the Primary SMTP Address for the account in Microsoft Exchange Server 2007 or 2010, which is displayed as the value of the mail attribute in the account properties.
Play Reminder Tone When Not in a Call	Specifies whether to play a sound along with the text reminder when the system is not in a call.
Show Information for Meetings Set to Private	Specifies whether to display details about meetings marked private.

For information about displaying the Calendar button on the Home screen, refer to [Customizing the Home Screen](#) on page 12. For more information about using Polycom Conferencing for Microsoft Outlook, refer to the *User's Guide for the Polycom RealPresence Group Series*. For more information about setting up

Microsoft Exchange Server 2007 or 2010 accounts to use the calendaring service, refer to the *Polycom Unified Communications Deployment Guide for Microsoft Environments* available on the Polycom website.

Using the Web Interface Home Page

When you click the **Home** link on the web interface, the default view shows you the following widgets:

- Place a Call
- Speed Dial
- Recent Calls
- Support Documents

For information on configuring Home screen settings for the local interface, refer to [Customizing the Home Screen](#) on page 12.

Place a Call

In the **Place a Call** section on the web interface Home page, you can place a call two different ways:

To call a Favorites contact

- 1 In the **Favorites** section, enter a name and click **Search**.
- 2 Select a contact name and click **Call**.

For information about editing Favorites contacts, refer to [Managing Favorites](#) on page 79.

To place a call manually

- 1 Click **Manual Dial**.
- 2 Enter the number.
- 3 Click **Call**.

The call is placed according to the default settings you selected in **Admin Settings > Network > Dialing Preferences**. You can select options other than the defaults in the two drop-down lists below the text entry field.

To require a password, select **Meeting Password** and enter a password in the field that displays below the check box.

Speed Dial

On the web interface Home page, you can call Speed Dial contacts and can edit the Speed Dial contact list.

To call speed dial contacts

>> In the Speed Dial section, select a contact from the list and click **Call**.

To add speed dial contacts

- 1 In the **Speed Dial** section, click **Edit**.
- 2 Enter a contact name and click **Search**.
- 3 In the contact you want to add, click **Add**.
- 4 To save your changes, click **Done**.

To remove speed dial contacts

- 1 In the **Speed Dial** section, click **Edit**.
- 2 In the contact you want to delete, click **Remove**.
- 3 To save your changes, click **Done**.

Recent Calls

On the web interface Home page, you can place calls to Recent Call contacts. You can also configure a Recent Calls list to display on the RealPresence Group system Home screen on both the web and local interfaces. The list includes the following information:

- Site name or number
- Whether call was placed or received
- Date and time
- Call duration

To dial a recent call from the web interface:

- >> On the web interface Home page's **Recent Calls** section, do one of the following:
- Find an entry and click the **Call** link next to the entry.
 - Click **More** to view a list of calls with more details, then select an entry and click **Call**.

To configure Recent Calls in the web interface:



- 1 Go to **Admin Settings > General Settings > System Settings > Recent Calls**.
- 2 To enable a Recent Calls list, configure these settings.

Setting	Description
Call Detail Report	Specifies whether to collect call data for the Call Detail Report. When selected, information about calls can be viewed through the Polycom RealPresence Group system's web interface and downloaded as a .csv file. When this setting is not selected, the system stops writing calls to the report.
Enable Recent Calls	Specifies whether to show Recent Calls on the local and web interfaces.
Maximum Number to Display	Specifies the maximum number of calls to display in the Recent Calls list.

- 3 To start a new list of recent calls, click **Clear Recent Calls**.
- 4 Click **Save**.

If you need more details about calls, you can view or download the Call Detail Report (CDR) from the Polycom RealPresence Group system's web interface. For more information about the CDR, refer to [Call Detail Report \(CDR\)](#) on page 129.

To view the Recent Calls screen using the Polycom Touch Control:

- 1 If the Polycom RealPresence Group system is paired with the Polycom Touch Control, touch  **Place a Call**.
- 2 Touch **Recent Calls**.
- 3 Touch  **Info** next to the entry you want to view.

Support Documents

To open a support document

- >> On the web interface's Home page, click a document link from the **Support Documents** list.
- To view a list of all available documents, click **View All**.

Security

To configure your RealPresence Group system using the system's web interface, you must use Internet Explorer version 9 on a Windows computer or Apple Safari on a Mac computer using OS X. Configure your browser to allow cookies.

To go to the web interface:

>> Open a web browser and enter the IP address of the RealPresence Group system using the `http://IPaddress` (for example, `http://10.11.12.13`).

For more information about using the web interface, refer to [Accessing the Web Interface](#) on page 97.



Use the HTTPS protocol to ensure that the configuration of all login information (such as user names and passwords) is transmitted using an encrypted channel, including those user names and passwords used to communicate with third-party systems on your network. Using HTTPS severely limits the ability of anyone on the network to discover these credentials.

Configuring Security Options

You can find security options and passwords in this part of the interface:

- In the local interface, go to **Administration > Security**.
The local interface has general, password, and remote access settings.
- In the web interface, go to **Admin Settings > Security**.
The web interface has global and local settings.

Settings are under different sections of the security interfaces. Not all systems show all of the options, and many settings in the web interface are unavailable in the local interface.

Configuring System Access for Polycom RealPresence Group Systems

Setting	Description
Allow Access to User Settings	<p>Specifies whether the User Settings screen is accessible to users via the local interface.</p> <p>Select this option if you want to allow users to change limited environmental settings.</p>
Enable Web Access	<p>Specifies whether to allow remote access to the system by the web. You can select any combination of web, telnet, and SNMP access.</p> <p>Note: The system restarts if you change the remote access settings. This setting does not deactivate the associated port, only the application. Use Web Access Port to disable the port.</p> <p>When the Polycom RealPresence Group system is paired with a Polycom Touch Control, web remote access must be enabled.</p>
Web Access Port (http)	<p>Specifies the port to use when accessing the system using the Polycom RealPresence Group system's web interface.</p> <p>If you change this from the default (port 80), specify a port number of 1025 or higher, and make sure the port is not already in use. You will need to include the port number with the IP address when you use the Polycom RealPresence Group system's web interface to access the system. This makes unauthorized access more difficult.</p>
Enable Telnet Access	<p>Specifies whether to allow remote access to the system by telnet commands. You can select any combination of web, telnet, and SNMP access.</p>
Enable SNMP Access	<p>Specifies whether to allow remote access to the system by SNMP. You can select any combination of web, telnet, and SNMP access.</p> <p>Note: The system restarts if you change the remote access settings.</p>
Allow Video Display on Web (local interface only)	<p>Specifies whether you can use the Polycom RealPresence Group system's web interface to view the room where the system is located, or video of calls in which the system participates.</p> <p>Note: This feature activates both near site and far site video displays in Web Director.</p>

For information about the sessions settings, refer to [Managing Remote Access](#) on page 94.

Configuring Local Accounts and Passwords



If you choose to delete a password and leave the setting empty, you will still see 8 asterisks in the setting after you save the change. This is a security measure that prevents others from knowing whether a password exists or how long a password is.

Setting	Description
Admin ID	<p>Specifies the ID for the administrator account. The default Admin ID is <code>admin</code>.</p> <p>Admin IDs are not case sensitive. They must be between 1 and 32 characters long. The first character must be a letter or a number, but the rest of the ID can be a mix of numbers, letters, and the following special characters:</p> <ul style="list-style-type: none"> • . (period, dot) • _ (underscore) • @ ("at" symbol) • - (hyphen) • # (hash tag, number sign) • \$ (US dollar sign)
Admin Room Password	<p>Specifies the password for administrator access when logging in to the system locally.</p> <p>When this password is set, you must enter it to configure the system Admin Settings using the remote control.</p> <p>The default Admin Room Password is the 14-digit system serial number from the System Detail screen or the back of the system.</p> <p>When the Polycom RealPresence Group system is paired with a Polycom Touch Control, you do not need to supply a room password.</p>
Use Room Password for Remote Access	<p>Specifies whether the Admin Room Password you set is the password required to access the system from the web or by telnet or SNMP. If this setting is enabled, you do not need to set a separate Remote Access Password.</p>

Setting	Description
Remote Access Password	Specifies the password for administrator access when logging in to the system remotely using the web interface or a telnet session. When this password is set, you must enter it to update the software or manage the system from a computer.
Meeting Password	Specifies the password users must supply to join multipoint calls on this system if the call uses the internal multipoint option, rather than a bridge. Do not set a meeting password if multipoint calls will include audio-only endpoints. Audio-only endpoints cannot participate in password-protected calls. If a meeting password has been configured for a multipoint meeting hosted on a Polycom RealPresence Group system, Microsoft Office Communicator clients cannot join the meeting.

Setting the Room and Remote Access Passwords

You can set the Admin Room Password and Admin Remote Access Password to allow for various levels of access to the system using the remote control, or from a computer.

All passwords appear as a series of asterisks as you type them in a configuration or login screen. To enter numbers in a password field on the local interface, use the remote control number buttons or the virtual keyboard that appears. To enter letters in a password field on the local interface, use the virtual keyboard.

To use the same password for both local and remote access:

- 1 Do one of the following:
 - In the local interface, go to **Administration > Security > Passwords**.
 - In the web interface, go to **Admin Settings > Security > Local Accounts**.
- 2 Select **Use Room Password for Remote Access**.

To reset a forgotten password:

If you forget a Polycom RealPresence Group system Admin or User password, you must use the restore button to run the setup wizard again in order to access the Admin Settings and reset the password. For more information about the restore button, refer to [Using the Restore Button on the Polycom RealPresence Group System](#) on page 134.

After the system restarts, it leads you through the setup wizard. You can enter new passwords when you set up the system.

If you forget a Polycom Touch Control Admin password, you must restore the device to its factory configuration.

Configuring Admin ID and Password for the Polycom Touch Control

You can set an Admin ID and password, which allows you to limit access to the Polycom Touch Control Administration settings.

To set a Polycom Touch Control admin ID and password:

- 1 From the Home screen touch  **Administration**.
An admin ID and password might be configured for the Touch Control Administration settings. The default ID is `admin` and the default password is `456`.
- 2 Touch the **Security** tab.
- 3 Set the following security settings.

Setting	Description
Admin ID	Specifies the ID for the administrator account. The default Admin ID is <code>admin</code> .
Admin Password	Specifies the password for administrator access when logging in to the Touch Control. When this password is set, you must enter it to configure the Touch Control Admin Settings. The password must not contain spaces.

Setting a Meeting Password

You can require participants of multipoint calls to enter a password prior to joining a call by creating a meeting password.

To set a meeting password:

- 1 Do one of the following:
 - In the local interface, go to **Administration > Security > Passwords**.
 - In the web interface, go to **Admin Settings > Security > Meeting Password** and select **Require a Meeting Password**.
- 2 Enter a password that has no spaces and is at least 3 characters long.

Enabling AES Encryption

AES encryption is a standard feature on all Polycom RealPresence Group systems. When it is enabled, the system automatically encrypts calls to other systems that have AES encryption enabled.

If encryption is enabled on the system, a locked padlock icon appears on the monitor when a call is encrypted. If a call is unencrypted, an unlocked padlock appears on the monitor. In a multipoint call, some connections might be encrypted while others are not. The padlock icon might not accurately indicate whether the call is encrypted if the call is cascaded or includes an audio-only endpoint. To avoid security risks, Polycom recommends that all participants communicate the state of their padlock icon verbally at the beginning of a call.



Points to note about AES Encryption:

- AES Encryption is not supported on systems registered to an Avaya H.323 gatekeeper.
- For Polycom RealPresence Group systems with a maximum speed of 6 Mbps for unencrypted calls, the maximum speed for encrypted SIP calls is 4 Mbps.
- Polycom RealPresence Group systems negotiate AES-256 and AES-128 in H.323 and SIP calls with other RealPresence Group systems.

To enable encryption:

- 1 Do one of the following:
 - In the local interface, go to **Administration > Security > Settings**.
 - In the web interface, go to **Admin Settings > Security > Global Security > Encryption**.

2 Configure these settings.

Setting	Description
Require AES Encryption for Calls AES Encryption in local interface	Specifies how to encrypt calls with other sites that support AES encryption. <ul style="list-style-type: none"> • Off—AES Encryption is disabled. • When Available—AES Encryption is used with any endpoint that supports it, even if the other endpoints in the call don't support it. • Required for Video Calls Only—AES Encryption is used for all video endpoints in the call. Video endpoints must support AES Encryption to participate in the call. • Required for All Calls—AES Encryption is used for all video endpoints in the call. All endpoints must support AES Encryption to participate in the call.

For more information about encryption configuration in a Microsoft Office Communications Server or Microsoft Lync Server environment, refer to the *Polycom Unified Communications Deployment Guide for Microsoft Environments*.

Configuring Encryption Settings for Integration with Microsoft Servers

Polycom RealPresence Group systems use the SRTP standard to support media encryptions in calls with Office Communicator. The encryption settings for each component also affect the ability to place encrypted calls.

Both the Microsoft Office Communications Server or Lync Server pool and the Polycom RealPresence Group system need to be configured to support encryption in order for calls to connect with encryption. If both components have encryption turned off, calls connect without encryption. If one component is set to require encryption and the other is not, calls fail to connect.

Calls from a Polycom RealPresence Group system to a Polycom RMX system using Microsoft Office Communications Server or Microsoft Lync Server require that the Polycom RealPresence Group system have encryption set to **When Available**.

Managing Remote Access

Remote access means using a Polycom video system in some way other than through the local interface, such as by using the web, a serial port, or telnet.

To configure remote access settings:

- 1 Do one of the following:
 - In the local interface, go to **Administration > Security > Remote Access**.
 - In the web interface, go to **Admin Settings > Security > Global Security > Access**.
- 2 Configure the following setting.

Setting	Description
Idle Session Timeout in Minutes	Specifies the number of minutes your remote use of the system through the web interface can be idle before the session times out. Select 1 to 480 minutes.

Managing User Access to Settings and Features

You can allow users to change common user preferences by providing access to the User Settings screen.

To allow users to customize the workspace, select the **Allow Access to User Settings** option to make the **User Settings** button available to users on the local interface's Home screen.

If the Polycom RealPresence Group system is paired with a Polycom Touch Control, selecting **Allow Access to User Settings** makes the **RealPresence Group** tab available on the Touch Control User Settings screen.

User Settings contains the following options, which are also available to administrators under Admin Settings:

- Meeting Password
- Backlight Compensation
- Mute Auto-Answer Calls
- Far Control of Near Camera
- Auto Answer Point-to-Point or Multipoint Video
- Allow Video Display on Web

Setting up Log Management

You can manage Polycom RealPresence Group system log files from the system's web interface. For more information about log management, refer to the following sections.

You can also manage Polycom Touch Control log files from the Touch Control interface. Refer to [Managing Polycom Touch Control Logs](#) for more information.

Setting up Polycom RealPresence Group System Log Management

The Polycom RealPresence Group system log files consist of the following information:

- System logs
- Call Detail Report (CDR)
- Configuration profile

You can download logs manually by using the Polycom RealPresence Group system's web interface.

To transfer the Polycom RealPresence Group system log manually:

- 1 In the web interface, go to Diagnostics > System > Download Logs .
- 2 Click Download system logs.

Look in your browser or download folder for a file named in the polycom_log_yyyymmddxxxxx.tgz format.

Managing Polycom Touch Control Logs

You can transfer the Touch Control logs to an external USB storage device.

To transfer Polycom Touch Control logs:

- 1 Ensure that a USB device is connected to the USB port on the right side of the Polycom Touch Control.
- 2 From the Home screen touch  **Administration**.
An admin ID and password might be configured for the Touch Control Administration settings. The default ID is admin and the default password is 456.
- 3 Under **Security**, select **Transfer Touch Control Logs to USB Device**.
A popup message displays when the log transfer completes successfully.

Managing the System Remotely

You can configure, manage, and monitor Polycom RealPresence Group systems from a computer using the system's web interface. You can also use Polycom CMA, Polycom RealPresence Resource Manager, SNMP, or the API commands.

- The Polycom RealPresence Group system's web interface requires only a web browser.
- Polycom CMA and RealPresence Resource Manager require the management application to be installed on your network.
- SNMP requires network management software on your network management station.
- For more information about the API commands, refer to the *Integrator's Reference Manual for the Polycom RealPresence Group Series*.

Using the Polycom RealPresence Group System Web Interface

You can use the Polycom RealPresence Group system's web interface to perform most of the calling and configuration tasks you can perform on the local system. The Polycom RealPresence Group system's web interface is supported only for Microsoft Internet Explorer version 9.0 on Windows 7 and Apple Safari on Mac OS X.

Accessing the Web Interface

To configure your browser to use the web interface:

- Be sure that you use Microsoft Internet Explorer 9.0 or Apple Safari as your web browser.
- Configure the browser to allow cookies.

To access the system using the web interface:

- 1 In your web browser address line, enter the system's IP address, for example, `http://10.11.12.13`.
- 2 Enter the Admin ID as the user name (default is `admin`), and enter the Admin Remote Access Password, if one is set.

Monitoring a Room or Call with the Web Interface

The monitoring feature within the web interface allows administrators of RealPresence Group systems to view a call or the room where the system is installed.

To enable room and call monitoring:

- 1 In the local interface, go to **Administration > Security > Remote Access**.
- 2 Enable **Allow Video Display on Web** to allow the room or call to be viewed remotely.

To monitor a room or call using the web interface:

- 1 In your web browser address line, enter the system's IP address.
- 2 Go to **Utilities > Tools > Monitoring**.
- 3 Perform any of the following tasks:
 - Place or end a call
 - View near and far sites
 - Use Call Control to change moderators and broadcast participants
 - Show content from a laptop, PC, DVD player, or document camera
 - Change camera sources
 - Adjust camera position
 - Adjust system volume
 - View camera presets
 - Zoom cameras
 - Mute and unmute the microphones

Managing System Profiles with the Web Interface

Administrators managing systems that support multiple applications can change system settings using profiles. You can store a RealPresence Group system profile on a computer as a `.profile` file using the web interface. The number of profiles you can save is unlimited.

The following settings are included in a profile:

- Home screen settings
- User access levels
- Icon selections
- Option keys
- System behaviors

Passwords are not included when you store a profile.



Polycom recommends using profiles only as a way to back up system settings. Attempting to edit a stored profile or upload it to more than one system on the network can result in instability or unexpected results.

To store a profile using the web interface:

- 1 In your web browser address line, enter the system's IP address.
- 2 Go to **Utilities > Services > Profile Center**.
- 3 Click **Download** next to **Current Settings Profile** to download the profile file from the system.
- 4 Save the file to a location on your computer.

To upload a profile using the web interface:

- 1 Reset the Polycom RealPresence Group system to restore default settings.
- 2 In your web browser address line, enter the system's IP address.
- 3 Go to **Utilities > Services > Profile Center**.
- 4 Next to **Upload Settings Profile**, click **Browse** and browse to the location of the profile .csv file on your computer.
- 5 Click **Open** to upload the .csv file to your system.

Sending a Message

If you are experiencing difficulties with connectivity or audio, you might want to send a message to the system that you are managing.

Only the near site can see the message; it is not broadcast to all the sites in the call.

To send a message using the web interface:

- 1** Go to **Diagnostics > Send a Message**.
- 2** In the Send a Message page, enter a message (up to 100 characters in length), then click **Send**.

The message is displayed for 15 seconds on the screen of the system that you are managing.

Configuring Servers

Setting Up a Directory Server

The global directory provides a list of other systems that are registered with the Global Directory Server and available for calls. The other systems appear in the directory, allowing users to place calls to other users by selecting their names.

You can configure the system to use one of the following directory servers in standard operating mode.

Directory Servers Supported	Authentication Protocols	Global Directory Groups	Entry Calling Information
Polycom GDS	Proprietary	Not Supported	Might include: <ul style="list-style-type: none"> • H.323 IP address (raw IPv4 address, DNS name, or H.323 extension) • ISDN number
LDAP with H.350 or Active Directory	Any of the following: <ul style="list-style-type: none"> • NTLM • Basic • Anonymous 	Not Supported	Might include: <ul style="list-style-type: none"> • H.323 IP address (raw IPv4 address, DNS name, H.323 dialed digits, H.323 ID, or H.323 extension) • SIP address (SIP URI) • ISDN number • Phone number*
Microsoft Lync Server 2010 (also Microsoft Office Communication Server 2007 R2)	NTLM v2 128bit encryption	Contact groups but not distribution lists	Might include: <ul style="list-style-type: none"> • SIP address (SIP URI)
* To successfully call a phone number from the LDAP directory, the phone number must be stored in one of the following formats: <ul style="list-style-type: none"> • +Country Code.Area Code.Number • +Country Code.(National Direct Dial Prefix).Area Code.Number 			

You can configure the system to use the following directory servers when the system is automatically provisioned by a Polycom CMA or Polycom RealPresence Resource Manager system.

Directory Servers Supported	Authentication Protocol	Global Directory Groups	Entry Calling Information
LDAP by a Polycom CMA system	NTLM only	Pre-defined groups from the LDAP directory are shown in Polycom RealPresence Group system's directory	Might include: <ul style="list-style-type: none"> • H.323 dialed digits, H.323 ID, or H.323 extension • Phone number*
Microsoft Lync Server 2010 (also Microsoft Office Communication Server 2007 R2)	NTLM	Contact groups but not distribution lists	Might include: <ul style="list-style-type: none"> • SIP address (SIP URI)
<p>* To successfully call a phone number from the LDAP directory, the phone number must be stored in one of the following formats:</p> <ul style="list-style-type: none"> • +Country Code.Area Code.Number • +Country Code.(National Direct Dial Prefix).Area Code.Number 			

To configure the Polycom GDS directory server:

- 1 In the web interface, go to **Admin Settings > Servers > Directory Servers** and select the **Polycom GDS Service Type**.
- 2 Configure these settings on the Directory Servers page.

Setting	Description
Server Address	Specifies the IP address or DNS address of the Global Directory Server. You can enter up to five addresses.
Password	Lets you enter the global directory password, if one exists.

To configure the LDAP directory server:

- 1 In the web interface, go to **Admin Settings > Servers > Directory Servers** and select the **LDAP Service Type**.

2 Configure these settings on the Directory Servers page.

LDAP Setting	Description
Server Address	Specifies the address of the LDAP directory server. With Automatic Provisioning, this setting is configured by the server and appears as read only.
Server Port	Specifies the port used to connect to the LDAP server. With Automatic Provisioning, this setting is configured by the server and appears as read only.
Base DN (Distinguished Name)	Specifies the top level of the LDAP directory where searches will begin. With Automatic Provisioning, this setting is configured by the server and appears as read only.
Authentication Type	Specifies the protocol used for authentication with the LDAP server: NTLM, BASIC, or Anonymous.
Use SSL (Secure Socket Layer)	Enables SSL for securing data flow to and from the LDAP server.
Domain Name	Specifies the domain name for authentication with the LDAP server.
User Name	Specifies the user name for authentication with LDAP server.
NTLM Password	Specifies whether to require a password for authentication with the LDAP server.
Password	Specifies the password for authentication with the LDAP server.

To configure the Microsoft Office Communications Server 2007 R2 or Microsoft Lync Server 2010 directory settings:

- 1 In the web interface, go to **Admin Settings > Network > IP > SIP Settings**.
- 2 Configure the SIP settings as described in [Configuring SIP Settings for Integration with Microsoft Servers](#) on page 31.
- 3 In the web interface, go to **Admin Settings > Servers > Directory Servers** and select the **Microsoft Lync Server 2010** Service Type.

4 Configure these settings on the Directory Servers page.

Setting	Description
Registration Status	Specifies whether the system is successfully registered with the Microsoft Office Communications Server or Microsoft Lync Server.
Domain Name	Specifies the Domain Name entered on the SIP Settings screen.
Domain User Name	Specifies the Domain User Name entered on the SIP Settings screen.
User Name	Specifies the User Name entered on the SIP Settings screen.

Setting Up SNMP

A RealPresence Group system sends SNMP (Simple Network Management Protocol) reports to indicate conditions, including the following:

- All alert conditions found on the RealPresence Group system's alert page
- Details of jitter, latency, and packet loss
- Low battery power for the remote control
- System power-on details
- Successful or unsuccessful administrator logon information
- Call failures for a reason other than a busy line
- User requests for help
- Telephone or video call connects or disconnects

Polycom RealPresence Group systems are compatible with SNMP versions 1 and 2c.

Downloading MIBs

In order to allow your SNMP management console application to resolve SNMP traps and display human readable text descriptions for those traps, you need to install Polycom MIBs (Management Information Base) on the computer you intend to use as your network management station. The MIBs are available for download from the Polycom RealPresence Group system's web interface.

To download the Polycom MIBs using the Polycom RealPresence Group system's web interface:

- 1 In your web browser address line, enter the RealPresence Group system's IP address.
- 2 Go to **Admin Settings > Servers > SNMP**.
- 3 Click the **Download MIB** link and follow the onscreen instructions.

Configuring for SNMP Management

To configure the RealPresence Group system for SNMP Management:

- 1 In the web interface, go to **Admin Settings > Servers > SNMP**.
- 2 Configure these settings on the SNMP screen.

Setting	Description
Enable SNMP	Allows administrators to manage the system remotely using SNMP.
Trap Version	Specifies the trap protocol that the system uses. <ul style="list-style-type: none"> • v2c—System uses the v2c trap. • v1—System uses the v1 trap.
Read-Only Community	Specifies the SNMP management community in which you want to enable this system. The default community is <code>public</code> . Note: Polycom does not support SNMP write operations for configuration and provisioning; the read-only community string is used for both read operations and outgoing SNMP traps.
Contact Name	Specifies the name of the person responsible for remote management of this system.
Location Name	Specifies the location of the system.
System Description	Specifies the type of video conferencing device.
Console IP Address	Specifies the IP address of the computer you intend to use as your network management station and the location for sending SNMP traps.

Using a Provisioning Service

If your organization uses the Polycom CMA or RealPresence Resource Manager system, you can manage Polycom RealPresence Group systems in dynamic management mode. In dynamic management mode, the following might be true:

- Polycom RealPresence Group systems are registered to a standards-based presence service, so presence states are shared with Contacts.
- Polycom RealPresence Group systems have access to a corporate directory that supports LDAP access.
- The Domain, User Name, Password, and Server Address fields are populated on the Provisioning Service screen.
- Configuration settings that are provisioned, or that are dependent on provisioned values, are read-only on the RealPresence Group system.
- The Polycom RealPresence Group system checks for new software from the Polycom CMA or RealPresence Resource Manager system every time it restarts and at an interval set by the service. It automatically accesses and runs any software updates made available by the Polycom CMA or RealPresence Resource Manager system.
- A CMA or RealPresence Resource Manager system administrator can upload a provisioned bundle from an already configured RealPresence Group system. When RealPresence Group systems request provisioning, the provisioned bundle and any automatic settings are downloaded. A RealPresence Group system user with administrative rights can change the settings on the RealPresence Group system after the provisioned bundle is applied. If you later download a new provisioned bundle from the CMA or RealPresence Resource Manager system, the new bundle overwrites the manual settings.
- If the system has previously registered successfully with a provisioning service but fails to detect the service when it restarts or checks for updates, an alert appears on the System Status screen. If the system loses registration with the provisioning service, it continues operating with the most recent configuration that it received from the provisioning service.
- If a Polycom Touch Control is connected to a provisioned RealPresence Group system, a CMA or RealPresence Resource Manager system with the following software versions can receive status updates from and provide software updates to the Polycom Touch Control.
 - CMA system version 6.2 or later
 - RealPresence Resource Manager system version 7.1 or later

Enabling or Disabling the Provisioning Service

You can register the Polycom RealPresence Group system with the Polycom CMA or RealPresence Resource Manager system in several ways:

- If the system detects a provisioning service on the network while running the setup wizard, it prompts you to enter information for registration with the service.

The setup wizard is available during initial setup, after a system reset with system settings deleted, or after using the restore button. For information about configuring the Polycom CMA or RealPresence Resource Manager system so that Polycom RealPresence Group systems detect and register with it, refer to the *Polycom Unified Communications Deployment Guide for Microsoft Environments*.

- You can enter the registration information and attempt to register by going to the **Admin Settings** in the Polycom Polycom RealPresence Group system's web interface.

To enable a provisioning service in the Admin Settings:

- 1 In the web interface, go to **Admin Settings > Servers > Provisioning Service**.
- 2 Select the **Enable Provisioning** setting.
- 3 Enter the **Domain, User Name, Password, and Server Address** for automatic provisioning. Multiple Polycom RealPresence Group systems can be registered to a single user.
- 4 Select **Register** or **Update**. The system tries to register with the Polycom CMA or RealPresence Resource Manager system using NTLM authentication.

To disable a provisioning service:

- 1 In the web interface, go to **Admin Settings > Servers > Provisioning Service**.
- 2 Disable the **Enable Provisioning** setting.

Provisioning Service Settings

If automatic provisioning is enabled but the system does not register successfully with the provisioning service, you might need to change the **Domain, User Name, Password, or Server Address** used for registration. For example, users might be required to periodically reset passwords used to log into the network from a computer. If such a network password is also used as the provisioning service password, you must update it on the Polycom RealPresence Group system, too. To avoid unintentionally locking a user out

of network access in this case, RealPresence Group systems will not automatically retry registration until you update the settings and register manually on the Provisioning Service page.

To configure the provisioning service settings:

- 1 In the web interface, go to **Admin Settings > Servers > Provisioning Service**.
- 2 Configure these settings.

Setting	Description
Domain	Specifies the domain for registering to the provisioning service.
User Name	Specifies the endpoint's user name for registering to the provisioning service.
Password	Specifies the password that registers the system to the provisioning service.
Server Address	Specifies the address of the Polycom CMA system running the provisioning service.

Keeping your Software Current

You can update your Polycom RealPresence Group system by going to support.polycom.com, navigating to **Documents and Downloads > Telepresence and Video**, and then downloading and installing the appropriate software. You can download and install software for the Polycom Touch Control and Polycom EagleEye Director, with no software or options key codes. You can also download and install Polycom Touch Control software from a web server.

You can also have your system automatically check for and apply software updates.

To automatically check for and apply software updates:

- 1 In the web interface, go to **Admin Settings > General Settings > Software Updates**.
- 2 Select **Automatic Software Updates**.

3 Configure these settings.

Setting	Description
Automatically Check for and Apply Software Updates	Enables settings that allow you to set up a schedule for automatically checking for and applying software updates to your system.
Start Time	Specifies the Hour , Minute , and AM/PM setting to start checking for updates.
Duration	Specifies how long the system should wait to determine whether updates are available.

Refer to the *Release Notes for the Polycom RealPresence Group Series* for information about the latest software version, including version dependencies. Refer to *Installing Software and Options for the Polycom RealPresence Group Series and Accessories* for detailed information about obtaining software key codes and updating your software.



If your organization uses a management system for provisioning endpoints, your Polycom RealPresence Group system might get software updates automatically.

Control and Navigation

Configuring Remote Control Behavior

You can customize the behavior of the remote control to support the users' environment.



Points to Note about remote control behavior:

- If the Polycom RealPresence Group system is paired and connected with a Polycom Touch Control, the remote control is disabled.
- The Polycom RealPresence Group system remote control IR transmits a modulated frequency of 38 kHz.

To configure remote control behavior:

- 1 In the web interface, go to **Admin Settings > General Settings > System Settings > Remote Control, Keypad, and Power**.
- 2 Configure these settings.

Setting	Description
Keypad Audio Confirmation	Specifies whether to play a voice confirmation of numbers selected with the remote control or keypad.
Numeric Keypad Function	Specifies whether pressing number buttons on the remote control or keypad moves the camera to presets or generates touch tones (DTMF tones). If this is set to Presets , users can generate DTMF tones by pressing the # key on the remote while on a video screen.

Setting	Description
Use Non-Polycom Remote	Configures the system to accept input from a programmable, non-Polycom remote control. In most cases the Polycom remote works as designed, even when this feature is enabled. However, try disabling this feature if you experience difficulty with the Polycom remote. For more information about Polycom RealPresence Group system IR codes, refer to the <i>Integrator's Reference Manual for the Polycom RealPresence Group Series</i> .
Channel ID	Specifies the IR identification channel to which the Polycom RealPresence Group system responds. Set the Channel ID to the same channel as the remote control. The default setting is 3. If the remote control is set to channel 3, it can control a Polycom RealPresence Group system set to any Channel ID. For more information about changing this setting, refer to Configuring the Remote Control Channel ID .
Chinese Virtual Keyboard	Specifies the type of onscreen keyboard to display for Simplified Chinese. This setting is available only when the system's Language is set to Simplified Chinese.
Hang-up Button Long Press	Specifies the behavior of the remote control Hang-up button when you press it for a long time: <ul style="list-style-type: none"> • Hang-up / Power Off—Holding down the Hang-up button powers off the RealPresence Group system. • Hang-up / Sleep—Holding down the Hang-up button puts the system to sleep. • Hang-up Only—Holding down the Hang-up button has no function other than hanging up the call.
# Button Function	Specifies the behavior of the # button on the remote control: <ul style="list-style-type: none"> • #, then @—Pressing buttons on the keypad displays numbers, then letters. For example, pressing the 5 key once displays the number 5 but pressing it three times displays the letter K. • @, then #—Pressing buttons on the keypad displays letters, then numbers. For example, pressing the 5 key once displays the letter J but pressing it four times displays the number 5.

Configuring the Remote Control Channel ID



You can configure the Channel ID so that the remote control affects only one Polycom RealPresence Group system, even if other systems are in the same room.





The Polycom Touch Control virtual remote control is always set to channel 3.

If the remote control is set to channel 3, it can control a Polycom RealPresence Group system set to any Channel ID. If the system does not respond to the remote control, set the remote control channel ID to 3 starting with step 3 in the following procedure. Then follow the entire procedure to configure the system and remote control channel ID settings.

To configure the channel ID on the remote control:

- 1 While blocking the IR signal from the remote control using your hand or some other object, press and hold  and  for 2-3 seconds.
- 2 After the LED on the front of the system flashes once, release both keys.
- 3 Enter a 2-digit ID between 00 and 15.
- 4 If the channel ID is saved successfully, the LED flashes twice. Otherwise, the LED flashes six times and you must repeat steps 1 - 3.

To retrieve the channel ID from the remote control:

- 1 While blocking the IR signal from the remote control using your hand or some other object, press and hold  and  for 2-3 seconds.
- 2 After the LED on the front of the system flashes once, release both keys.
- 3 Enter a 2-digit ID between 00 and 15.
- 4 If you entered the current channel ID, the LED flashes twice. Otherwise, the LED flashes six times and you must repeat steps 1 - 3.

To configure the channel ID for a Polycom RealPresence Group system and remote control in the web interface:

- 1** Go to **Admin Settings > General Settings > System Settings > Remote Control, Keypad, and Power**.
- 2** Select the **Channel ID**.
- 3** Click **Save**.

The channel ID must be the same on the remote control and in the web interface.

Connecting Control and Accessibility Equipment

The Polycom RealPresence Group 300 and the Polycom RealPresence Group 500 systems provide one serial port to allow you to control the system through a touch-panel using the API.

The Polycom RealPresence Group 700 system also provides one serial port, but depending on your system's capabilities, you might be able to use the RS-232 serial port to control the system through a touch-panel using the API.

Make sure that the system is powered off before you connect devices to it.

Connecting Non-Polycom Touch-Panel Controls

You can connect an AMX or Crestron control panel to a Polycom RealPresence Group system's RS-232 serial port as part of a custom room installation. You will need to program the control panel. Refer to the *Integrator's Reference Manual for the Polycom RealPresence Group Series* for information about the API commands.

Configuring RS-232 Serial Port Settings

- 1 In the web interface, go to **Admin Settings > General Settings > Serial Ports**.
- 2 Configure these settings in the sections on the Serial Ports page.

Setting	Description
RS-232 Mode	Specifies the mode used for the serial port. Available settings depend on the Polycom RealPresence Group system model. <ul style="list-style-type: none"> • Off—Disables the serial port. • Control—Receives control signals from a touch-panel control. Allows any device connected to the RS-232 port to control the system using API commands.
Baud Rate, Parity, Data Bits, Stop Bits	Set these to the same values that they are set to on the serial device.
RS-232 Flow Control	This setting works with RS-232 modes that are not currently available. The setting is not currently configurable.

Setting Up the Polycom Touch Control Device

The Polycom Touch Control allows you to control a Polycom RealPresence Group system.

Follow these steps to get started with the Polycom Touch Control. Refer to the *Setting Up the Polycom Touch Control* and *Installing Software and Options for the Polycom RealPresence Group Series and Accessories* documents for more information.

To set up the Polycom Touch Control Device:

- 1 Ensure that the correct software is installed on the Polycom RealPresence Group system that you want to control, and that you have completed the setup wizard on the system.

Refer to *Installing Software and Options for the Polycom RealPresence Group Series and Accessories* for more information about updating the Polycom Touch Control software.

- 2 Connect the Ethernet cable to the underside of the Polycom Touch Control.
- 3 If you intend to use the Polycom Touch Control to show content from a computer, connect the USB cable to the underside of the Polycom Touch Control.

- 4 If you want to connect the stand, route the Ethernet and USB cables through the opening in the stand. Then attach the stand to the Polycom Touch Control by tightening the mounting screw with a screwdriver.
- 5 Plug the Ethernet cable into the wall outlet:
 - If your room provides Power Over Ethernet, you can connect the Ethernet cable directly to a LAN outlet.
 - If your room does not provide Power Over Ethernet, you must connect the Ethernet cable to the power supply adapter. Then connect the power supply adapter to a LAN outlet and power outlet.

The Polycom Touch Control powers on and displays the language selection screen.

- 6 Choose your language and follow the onscreen instructions to pair the Polycom Touch Control with your RealPresence Group system, or select **Pair Later** on the Pairing screen to skip pairing.
- 7 After the Polycom Touch Control connects to the network, enter the RealPresence Group system IP address and touch **Connect**. By default, the IP address of the RealPresence Group system is displayed on the bottom of its Home screen. If the RealPresence Group system is configured to allow pairing and you enter the IP address for the system correctly, the Touch Control displays a prompt for the Polycom RealPresence Group system admin user ID and password.

When the Polycom Touch Control has paired and connected with the RealPresence Group system, the Polycom Touch Control displays a success message, and the menus on the RealPresence Group system monitor become unavailable. For more information about pairing, refer to [Pairing](#) on page 116.

Pairing and Unpairing a Polycom Touch Control Device and a Polycom RealPresence Group System

When you configure the Polycom Touch Control to pair with a particular Polycom RealPresence Group system, the Polycom Touch Control makes an IP connection to the RealPresence Group system. If the connection is lost for any reason, the Polycom Touch Control automatically attempts to restore the connection.

The Polycom Touch Control connects to the RealPresence Group system over a TLS socket, providing a reliable, secure communication channel between the two systems. The Polycom Touch Control initiates all pairing connections and attaches to port 4122 on the RealPresence Group system.

You can pair the Polycom Touch Control and Polycom RealPresence Group system during initial Polycom Touch Control setup, as described in the steps on the previous page.

After you have completed Polycom Touch Control setup, you can pair to a different RealPresence Group system using Polycom Touch Control settings and unpair using the web interface.

When you use a Polycom Touch Control with the Polycom RealPresence Group system, you must be sure to update the RealPresence Group software before you update the Polycom Touch Control software. Only Polycom Touch Control software versions 4.x or later work with Polycom RealPresence Group systems.

The following table describes the pairing states:

State	Description
Paired	The Polycom Touch Control is successfully connected to the Polycom RealPresence Group system through the pairing process, including providing the Polycom RealPresence Group admin ID and password. A single Polycom Touch Control can be paired to multiple Polycom RealPresence Group systems and, once paired, the Polycom Touch Control can switch between RealPresence Group systems without needing to enter admin IDs or passwords.
Unpaired	The ability to pair or connect to the Polycom Touch Control is disabled on the Polycom RealPresence Group system. The only way to unpair is to follow the procedure described in Unpairing on page 116.
Connected	A Polycom Touch Control has an active pairing connection to the Polycom RealPresence Group system. A single Polycom Touch Control can be paired to multiple Polycom RealPresence Group systems, but can be connected to only one RealPresence Group system at a time.
Disconnected	The Polycom Touch Control does not have an active pairing connection to an RealPresence Group system, but is still paired if at least one RealPresence Group system that has previously paired with the Polycom Touch Control has not unpaired.

Pairing

To pair the Polycom Touch Control and Polycom RealPresence Group system during setup:

- >> After selecting a language, enter the RealPresence Group system IP address in the Polycom Touch Control interface and touch **Connect**.



If you do not want to pair during setup, select **Pair Later**. If you choose to skip pairing, many Polycom Touch Control features are not available. You can pair at a later time.

To pair the Polycom Touch Control and Polycom RealPresence Group system after setup, using the Polycom Touch Control:

- 1 On the Polycom Touch Control Home screen, touch **System**.
- 2 Scroll to **Device Connection Status** and then touch  Info next to the RealPresence Group system.
- 3 Touch **View Pairing Settings**.
- 4 Change the RealPresence Group system IP address and touch **Connect**.

To pair the Polycom Touch Control and Polycom RealPresence Group system after setup, using the Polycom RealPresence Group system's web interface:

- 1 Go to **Admin Settings > General Settings > Pairing > Manage Devices**.
- 2 Enable the **Allow Pairing** setting.

After the RealPresence Group system and the Polycom Touch Control are paired, the Polycom RealPresence Group system's web interface and the Polycom Touch Control interface display information about each other and about their connection status.

Unpairing

You can unpair the Polycom Touch Control and RealPresence Group system using the web interface.

To unpair the Polycom Touch Control and Polycom RealPresence Group using the web interface:

- 1 Go to **Admin Settings > General Settings > Pairing > Manage Devices**.
- 2 Disable **Allow Pairing** or select **Forget this Device**.

The RealPresence Group system cannot pair with any Polycom Touch Control while **Allow Pairing** is disabled.

Configuring Contact Information

You can configure contact information for your Polycom RealPresence Group system so that others know who to call when they need assistance.

To configure system contact information:

- 1 In the web interface, go to **Admin Settings > General Settings > My Information > Contact Information**.
- 2 Configure these settings.

Setting	Description
Contact Person	Specifies the name of the system administrator.
Contact Number	Specifies the phone number for the system administrator.
Contact Email	Specifies the email address for the system administrator.
Contact Fax	Specifies the fax number for the system administrator.
Tech Support	Specifies the name of the person who provides technical support.
City	Specifies the city where the system administrator is located.
State/Province	Specifies the state or province where the system administrator is located.
Country	Specifies the country where the system administrator is located.

Configuring Regional Settings

You can configure regional settings for the Polycom RealPresence Group systems and for Polycom Touch Control devices. To do so, refer to [Configuring Polycom RealPresence Group System Location Settings](#) and [Configuring Polycom Touch Control Regional Settings](#) on page 120.

Configuring Polycom RealPresence Group System Location Settings

To configure location settings:

- 1 In the web interface, go to **Admin Settings > General Settings > My Information > Location**.
- 2 Configure these settings.

Setting	Description
Country	Specifies the country where the system is located. Changing the country automatically adjusts the country code associated with your system.
Country Code	Displays the country code associated with the country where the system is located.

Configuring Polycom RealPresence Group System Language Settings

To configure the Polycom RealPresence Group system language settings:

- >> Do one of the following:
- In the local interface, go to **Administration > Location > Language** and select the language to use in the interface.
 - In the web interface, go to **Admin Settings > General Settings > Language** and select the **System Language** and **Web Language** to use in the interface.

Configuring Polycom RealPresence Group System Date and Time Settings

To configure the Polycom RealPresence Group system date and time settings:

- 1 Go to one of the following locations to configure these settings:
 - In the local interface, go to **Administration > Location > Date and Time**.
 - In the web interface, go to **Admin Settings > General Settings > Date and Time > System Time**.

2 Configure these settings.

Setting	Description
Date Format	Specifies how the date is displayed in the interface. Note: This a web-only setting.
Time Format	Specifies how the time is displayed in the interface.
Auto Adjust for Daylight Saving Time	Specifies the daylight saving time setting. When you enable this setting, the system clock automatically changes for daylight saving time. Note: This a web-only setting.
Time Zone	Specifies the time difference between GMT (Greenwich Mean Time) and your location.
Time Server	Specifies whether the connection to a time server is automatic or manual for system time settings. You can also select Off to enter the date and time yourself.
Primary Time Server Address	Specifies the address of the primary time server to use when Time Server is set to Manual .
Secondary Time Server Address	Specifies the address of the time server to use when the Primary Time Server Address does not respond. This is an optional field.
Date and Time settings	<ul style="list-style-type: none"> If the Time Server is set to Manual or Auto, these settings are not displayed. If the Time Server is set to Off, these settings are configurable.

3 In the web interface, go to **Admin Settings > General Settings > Date and Time > Time in Call**.

4 Configure these settings.

Setting	Description
Show Time in Call	Specifies the time display in a call: <ul style="list-style-type: none"> Elapsed Time—Displays the amount of time in the call. System Time—Displays the system time on the screen during a call. Off—Time is not displayed.

When to Show	<p>Specifies when the time should be shown:</p> <ul style="list-style-type: none"> • Start of the call only—Displays only when the call begins • Entire call—Displays continuously throughout the call • Once per hour—Displays at the beginning of the hour for one minute • Twice per hour—Displays at the beginning of the hour and midway through the hour for one minute
Show Countdown Before Next Meeting	<p>This setting is displayed only when the calendaring service has been enabled.</p> <p>When enabled, it displays a timer that counts down to the next scheduled meeting 10 minutes before that meeting. If a timer is already showing, the countdown timer replaces it 10 minutes before the next scheduled meeting.</p>

Configuring Polycom Touch Control Regional Settings

To configure the Polycom Touch Control regional settings:

- 1 From the Home screen touch  **Administration**.
- 2 Touch the **Location** tab.
- 3 Select a language from the **Language** menu.
- 4 Configure the following settings under **Date and Time**.

Setting	Description
Time Zone	Specifies the time difference between GMT (Greenwich Mean Time) and your location.
Time Server	<p>Specifies connection to a time server for automatic Touch Control time settings.</p> <p>The date and time must be manually reset every time the Touch Control restarts, in the following cases:</p> <ul style="list-style-type: none"> • Time Server is set to Off. • Time Server is set to Manual or Auto, but the Touch Control cannot connect to a time server successfully.
Time Server Address	Specifies the address of the time server to use when Time Server is set to Manual .
Time Format	Specifies your format preference for the time display and lets you enter your local time.

Configuring Sleep Settings

Customizing Sleep Behavior

To configure when the system goes to sleep:

- 1** In the web interface, click **Admin Settings > Audio/Video > Sleep > Sleep**.
- 2** Select the number of minutes the system can be idle before it goes to sleep.

Diagnostics, Status, and Utilities

The Polycom RealPresence Group systems provide various screens that allow you to review information about calls made by the system and to review network usage and performance.

Diagnostics Screens

To access the Diagnostics screens on the local interface:

>> Go to **System**.

The System screens provide system detail, network, and usage information as well as system status and diagnostics information.

To access the Diagnostics screens using the Polycom RealPresence Group system's web interface:

- 1 In your web browser address line, enter the RealPresence Group system's IP address.
- 2 Enter the Admin ID as the user name (default is `admin`), and enter the Admin Remote Access Password, if one is set.
- 3 Click **Diagnostics** from any page in the web interface.

For EagleEye Director Video Diagnostics, go to **Diagnostics > Video > Cameras > Polycom EagleEye Director**.

You can find system information by clicking the **System** link in the blue bar at the top of the page.

The Diagnostics page has the following groups of settings in addition to the Send a Message application:

- System
- Network
- Audio and Video Tests

System Diagnostics

Diagnostic Screen	Description
<p>Active Alerts (local interface only, under System > Status)</p>	<p>Displays the status of any device or service listed within the Status screens that has a current status indicator of red. Alerts are listed in the order they occurred.</p>
<p>Call Statistics</p>	<p>Displays information about the call in progress. In multipoint calls, the Call Statistics screens show most of this information for all systems in the call.</p> <ul style="list-style-type: none"> • Call speed (send and receive) • Call type • Video protocol, annexes, and format in use (send and receive). • Audio protocol in use (send and receive). • Active network resilience methods; this field is visible only if the system is currently using error concealment • Number of packets lost and percentage packet loss (transmit and receive) in IP calls • Encryption type, key exchange algorithm type, and key exchange check code (if the encryption option is enabled and the call is encrypted) • Audio and video data rates specified (transmit and receive) • Video data rate and frame rate in use (transmit and receive) • Video packet loss and jitter in IP calls • Audio packet loss and jitter in IP calls • Content details (protocol, format, data rate, frame rate, packets lost) • Video forward error correction (FEC) errors • Far site details <p>If the system is not in a call, the page displays The System is not currently in a call.</p>

Diagnostic Screen	Description
System Status (for the local interface, these settings appear under System > Status)	Displays the following system status information: <ul style="list-style-type: none"> • Call control: Auto-Answer Point-to-Point and Meeting Password • Audio: Microphones, SoundStation IP, SoundStructure, EagleEye Director • LAN: IP Network • Servers: <ul style="list-style-type: none"> – Always shows: Gatekeeper, SIP Registrar Server – Shows the active Global Directory Server, LDAP Server, or Microsoft Server – If enabled, shows Provisioning Service, Calendaring Service, Presence Service If the Polycom RealPresence Group system detects an EagleEye Director, a status line for the device is displayed. When a system device or service encounters a problem, you see an alert next to the System button on the menu.
Download Logs (web only)	Enables you to save system log information.
System Log Settings (web only)	Specifies the Log Level to use; allows you to enable Remote Logging, H.323 Trace, and SIP Trace; allows you to Send Diagnostics and Usage Data to Polycom.
Restart System (web interface) Reset System (local interface)	Restart in the web interface cycles power to the system. Note: If a password is set, you must enter it to reset the system. In the local interface, this setting is under System > Diagnostics and is named Reset System . When you select this setting using the remote control, you have the option to do the following: <ul style="list-style-type: none"> • Keep your system settings (such as system name and network configuration) or restore system settings. • Keep or delete the directory stored on the system. System reset does not affect the global directory. You might want to download the CDR and CDR archive before you reset the system. Refer to Call Detail Report (CDR) on page 129.

Network

Diagnostic Screen	Description
Near End Loop (local interface only)	<p>Tests the internal audio encoders and decoders, the external microphones and speakers, the internal video encoders and decoders, and the external cameras and monitors.</p> <p>Monitor 1 displays the video and plays the audio that would be sent to the far site in a call.</p> <p>This test is not available when you are in a call.</p>

Audio and Video Tests

Diagnostic Screen	Description
Color Bars (local interface only)	<p>Tests the color settings of your monitor for optimum picture quality.</p> <p>If the color bars generated during the test are not clear, or the colors do not look correct, the monitor needs to be adjusted.</p>
Speaker Test	<p>Tests the audio cable connections. A 473 Hz audio tone indicates that the local audio connections are correct.</p> <p>If you run the test from the system during a call, the far site will also hear the tone.</p> <p>If you run the test from the Polycom RealPresence Group system's web interface during a call, the people at the site you are testing will hear the tone, but you will not.</p>
Audio Meter	<p>Measures the strength of audio signals from the microphone or microphones, far-site audio, VCR audio, and any device connected to the audio line in.</p> <ul style="list-style-type: none"> To check the microphone or microphones, speak into the microphone. To check far-site audio, ask a participant at the far site to speak or call a phone in the far-site room to hear it ring.

Diagnostic Screen	Description
Audio Meter (continued)	<p>The Audio Meters indicate peak signal levels. Set signal levels so that you see peaks between +3dB and +7dB with normal speech and program material. Occasional peaks of +12dB to +16dB with loud transient noises are considered acceptable. A meter reading of +20dB corresponds to 0dBFS in the Polycom RealPresence Group system audio. A signal at this level is likely clipping the audio system.</p> <p>Meters function only when the associated input is enabled.</p> <p>Note: Some audio meters are unavailable when a SoundStructure digital mixer is connected to the Polycom RealPresence Group system.</p>
Camera Tracking	<p>Provides diagnostics specific to the EagleEye Director.</p> <p>Audio</p> <p>Verifies microphone functionality. To use this feature, speak aloud and verify that you can see dynamic signal indications for two vertical microphones and five horizontal microphones. If no signal indication appears for a specific microphone, manually power off the EagleEye Director and then power it back on.</p> <p>Also verifies the reference audio signal: Set up a video call. Let the far side speak aloud and verify that you can see dynamic signal indications for the two reference audio meters. If no signal indication appears for a specific microphone, make sure the reference cable is connected firmly.</p> <p>After you verify microphone functionality, calibrate the camera again.</p> <p>Video</p> <ul style="list-style-type: none"> • Left Camera shows video from the left camera. • Right Camera shows video from the right camera. • Color Bars displays the color bar test screen.

System Logs

You can use the Polycom RealPresence Group system's web interface to download system logs. For information about downloading logs, refer to [Setting up Log Management](#) on page 95.

You can also manage Polycom Touch Control log files from the Touch Control interface. For more information about Polycom Touch Control log management, refer to [Managing Polycom Touch Control Logs](#) on page 95.

Downloading System Logs

The support information package contains logs, configuration settings, and other diagnostic information.

To download a system log using the web interface:

- 1 Click **Diagnostics > System > Download Logs**.
- 2 Click **Download system log** and then specify a location on your computer to save the file.

In the dialog boxes that appear, designate where you want the file to be saved.

System Log Settings

To configure system log settings using the web interface:

- 1 In your web browser address line, enter the RealPresence Group system's IP address.
- 2 Enter the Admin ID as the user name (default is `admin`), and enter the Admin Remote Access Password, if one is set.
- 3 Click **Diagnostics > System > System Log Settings**.
- 4 Configure these settings.

Setting	Description
Log Level	Sets the minimum log level of messages stored in the Polycom RealPresence Group system's flash memory. DEBUG logs all messages. WARNING logs the fewest number of messages. Polycom recommends leaving this setting at the default value of DEBUG.
Enable Remote Logging	Specifies whether remote logging is enabled. Enabling this setting causes the Polycom RealPresence Group system to send each log message to the specified server in addition to logging it locally.

Setting	Description
Enable Remote Logging <i>(continued)</i>	The system immediately begins forwarding its log messages when you click Update . Encryption is not supported for remote logging, so Polycom recommends remote logging only for secure, local networks.
Enable H.323 Trace	Logs additional H.323 connectivity information.
Enable SIP Trace	Logs additional SIP connectivity information.
Send Diagnostics and Usage Data to Polycom	Sends crash log server information to Polycom to help us analyze and improve the product.

Downloading EagleEye Director Logs

The Polycom EagleEye Director logs contain important status and debug information that is not included in the logs available for the RealPresence Group system.

Follow these steps to download the log information to a USB device:

- 1** Attach a USB storage device formatted in FAT32 to the back panel of the EagleEye Director.
- 2** Restart the EagleEye Director by following these steps:
 - a** Unplug the 12v adaptor attached to the side of the EagleEye Director.
 - b** Wait a 5 seconds.
 - c** Plug the 12v adaptor into the side of the EagleEye Director.
It could take up to two minutes for the EagleEye Director to restart.
- 3** Remove the USB storage device.

A log file using the name format of `rabbiteye_info_XXXXX.tar.gz` is generated on the USB storage device.

Call Detail Report (CDR)

When enabled by going to **Admin Settings > General Settings > System Settings > Recent Calls** in the Polycom RealPresence Group system's web interface, the Call Detail Report (CDR) provides the system's call history. Within 5 minutes after ending a call, the CDR is written to memory and then you can download the data in CSV format for sorting and formatting.

Every call is added to the CDR, whether it is made or received. If a call does not connect, the report shows the reason. In multipoint calls, each far site is shown as a separate call, but all have the same conference number.

The size of a CDR is virtually unlimited, but can become unmanageable if you don't download the record periodically. If you consider that 150 calls result in a CDR of approximately 50 KB, you might set up a schedule to download and save the CDR after about every 1000 - 2000 calls just to keep the file easy to download and view. Remember that your connection speed also affects how fast the CDR downloads.

To view and download the CDR using the Polycom RealPresence Group system's web interface:

- 1** Click **Utilities > Services > Call Detail Report (CDR)** to view the details of the file.
- 2** Click **Download CDR** and then specify a location on your computer to save the file.

Information in the CDR

The following table describes the data fields in the CDR.

Data	Description
Row ID	Each call is logged on the first available row. A call is a connection to a single site, so there might be more than one call in a conference.
Start Date	The call start date, in the format dd-mm-yyyy.
Start Time	The call start time, in the 24-hour format hh:mm:ss.
End Date	The call end date.
End Time	The call end time.
Call Duration	The length of the call.
Account Number	If Require Account Number to Dial is enabled on the system, the value entered by the user is displayed in this field.
Remote System Name	The far site's system name.
Call Number 1	The number dialed from the first call field, not necessarily the transport address. For incoming calls — The caller ID information from the first number received from a far site.
Call Number 2 (If applicable for call)	For outgoing calls — The number dialed from the second call field, not necessarily the transport address. For incoming calls — The caller ID information from the second number received from a far site.

Data	Description
Transport Type	The type of call — Either H.323 (IP) or SIP.
Call Rate	The bandwidth negotiated with the far site.
System Manufacturer	The name of the system manufacturer, model, and software version, if they can be determined.
Call Direction	In — For calls received. Out — For calls placed from the system.
Conference ID	A number given to each conference. A conference can include more than one far site, so there might be more than one row with the same conference ID.
Call ID	Identifies individual calls within the same conference.
Endpoint Alias	The alias of the far site.
Endpoint Additional Alias	An additional alias of the far site.
Endpoint Remote Type	Terminal, gateway, or MCU.
Endpoint Transport Address	The actual address of the far site (not necessarily the address dialed).
Audio Protocol (Tx)	The audio protocol transmitted to the far site, such as G.728 or G.722.1.
Audio Protocol (Rx)	The audio protocol received from the far site, such as G.728 or G.722.
Video Protocol (Tx)	The video protocol transmitted to the far site, such as H.263 or H.264.
Video Protocol (Rx)	The video protocol received from the far site, such as H.261 or H.263.
Video Format (Tx)	The video format transmitted to the far site, such as CIF or SIF.
Video Format (Rx)	The video format received from the far site, such as CIF or SIF.
Q.850 Cause Code	The Q.850 cause code showing how the call ended.
Average Percent of Packet Loss (Tx)	The combined average of the percentage of both audio and video packets transmitted that were lost during the 5 seconds preceding the moment at which a sample was taken. This value does not report a cumulative average for the entire H.323 call. However, it does report an average of the sampled values.

Data	Description
Average Percent of Packet Loss (Rx)	The combined average of the percentage of both audio and video packets received that were lost during the 5 seconds preceding the moment at which a sample was taken. This value does not report a cumulative average for the entire H.323 call. However, it does report an average of the sampled values.
Average Packets Lost (Tx)	The number of packets transmitted that were lost during an H.323 call.
Average Packets Lost (Rx)	The number of packets from the far site that were lost during an H.323 call.
Average Latency (Tx)	The average latency of packets transmitted during an H.323 call based on round-trip delay, calculated from sample tests done once per minute.
Average Latency (Rx)	The average latency of packets received during an H.323 call based on round-trip delay, calculated from sample tests done once per minute.
Maximum Latency (Tx)	The maximum latency for packets transmitted during an H.323 call based on round-trip delay, calculated from sample tests done once per minute.
Maximum Latency (Rx)	The maximum latency for packets received during an H.323 call based on round-trip delay, calculated from sample tests done once per minute.
Average Jitter (Tx)	The average jitter of packets transmitted during an H.323 call, calculated from sample tests done once per minute.
Average Jitter (Rx)	The average jitter of packets received during an H.323 call, calculated from sample tests done once per minute.
Maximum Jitter (Tx)	The maximum jitter of packets transmitted during an H.323 call, calculated from sample tests done once per minute.
Maximum Jitter (Rx)	The maximum jitter of packets received during an H.323 call, calculated from sample tests done once per minute.



When the Polycom RealPresence Group system is paired with a Polycom Touch Control, the screen saver logo displays on the system's monitor but not the Polycom Touch Control screen.

Troubleshooting

For more troubleshooting information, you can search the Knowledge Base at support.polycom.com.

Placing a Test Call

When you finish configuring the system, you can call a Polycom video site to test your setup. You can find a list of worldwide numbers that you can use to test your Polycom RealPresence Group system at www.polycom.com/videotest.

If you have trouble making video calls:

- To find out if the problem exists in your system, ask the person you were trying to reach to call you instead.
- Find out if the system you are calling has its power turned on and is functioning properly.
- If you can make calls but not receive them, make sure that your system is configured with the correct IP address.

Resetting a RealPresence Group System

If the system is not functioning correctly or you have forgotten the Admin Room Password, you can reset the system with **Delete System Settings** enabled. This procedure effectively refreshes your system, deleting all settings except the following one:

- Current software version
- Remote control channel ID setting
- Directory entries
- CDR data and logs

To reset the system using the local interface:

- 1** Go to **System > Diagnostics > Reset System**.
- 2** Enter the system's **Serial Number**.
- 3** Enable **Delete System Settings**.
- 4** Click **Reset System**.

After about 15 seconds, the system restarts and displays the setup wizard.

Using the Restore Button on the Polycom RealPresence Group System

You can use the hardware restore button on the Polycom RealPresence Group system to perform a factory restore of the system. A factory restore completely erases the system and restores it to the software version and default configuration stored in its factory partition. If you follow this procedure while a USB storage device is connected, the system restores from the USB device instead of the system's factory partition.

The restore button is on the bottom of the Polycom RealPresence Group 300 and 500 systems, as shown in the following figure.

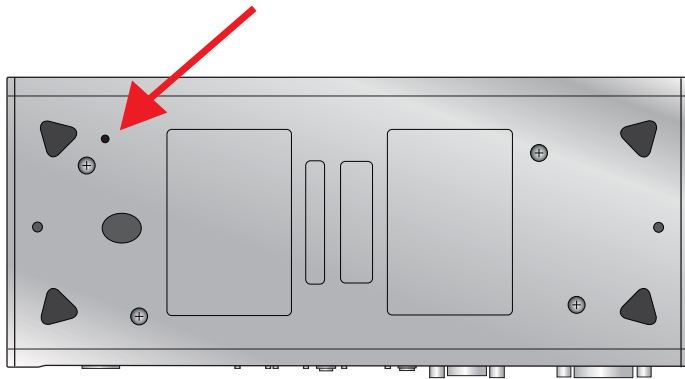

The restore button is on the front of the Polycom RealPresence Group 700 system, as shown in the following figure.

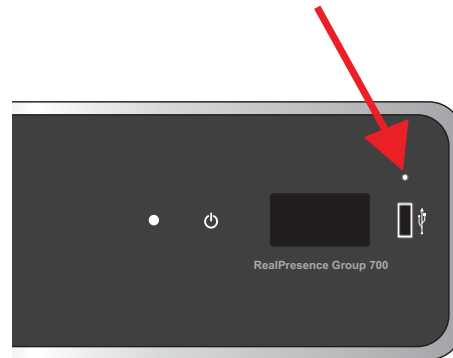

The factory restore operation completely erases the system's flash memory and reinstalls the software version and default configuration stored in its factory partition.

The following items are *not* saved:

- Software updates
- All system settings including option keys and the remote control channel ID
- Directory entries
- CDR data



If you follow the procedure to restore the system to factory defaults while a USB storage device is connected, the system restores from the USB device instead of the system's factory partition.

To reset the system to its factory partition software using the restore button:

- 1 While the system is powered off, press and hold the restore button.
- 2 While holding the restore button, press the power button once.
- 3 Keep holding the restore button for 5 more seconds, then release it.

During the factory restore process, the system displays the Polycom startup screen on HDMI monitors. Other types of monitors will be blank. Do not power off the system during the factory restore process. The system restarts automatically when the process is complete.

Deleting Files

You can remove customer data and configuration information from the system for security purposes.

To perform a logical delete of the system files:

- 1 Power off the system by holding down the Power sensor for 3 to 5 seconds.
- 2 Unplug all network connections.
- 3 Perform a factory restore.
- 4 Wait for the system to start up and display the setup wizard.
- 5 Power off the system.

Performing a Factory Restore on the Polycom Touch Control

If the Polycom Touch Control is not functioning correctly or you have forgotten the Administration password, you can use the restore button to reset the device. This operation completely erases the device's settings and reinstalls the software.

The restore button is on the underside of the Polycom Touch Control, as shown in the following figure.

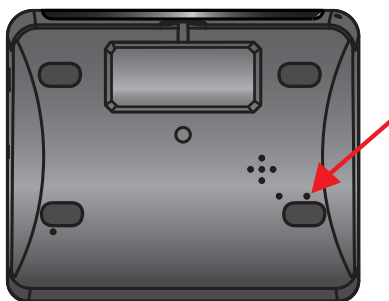

To reset the Polycom Touch Control using the restore button:

- 1 Power off the Polycom Touch Control.
- 2 Disconnect the LAN cable.
- 3 Disconnect all USB devices.
- 4 Press and hold the factory restore button while you reconnect the LAN cable to the device. Continue to hold the factory restore button down for about 10 seconds after the device powers on.

If the device requires login information, the default for the admin ID is `admin` and for the password, it's `456`.

During the factory restore process, the default platform and applications are reinstalled. Do not power off the device during the factory restore process. The device displays a success message when the process is complete.

Performing a Factory Restore on the Polycom EagleEye Director

If the Polycom EagleEye Director is not functioning correctly or you need to recover from a corrupted partition, you can use the restore button to reset the device. This operation completely erases the camera's settings and reinstalls the software.

The following figure shows you the location of the restore button on the back of the Polycom EagleEye Director.

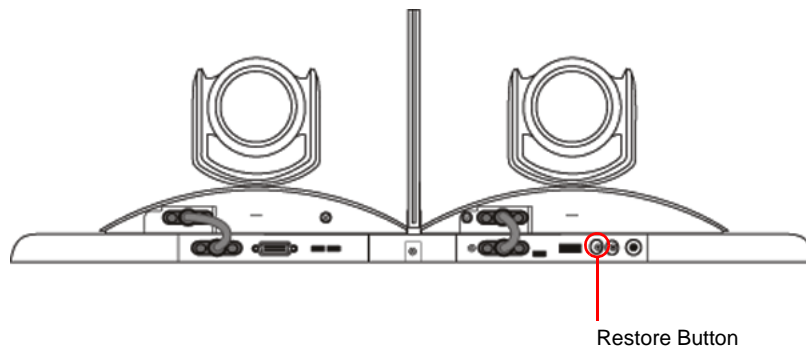

To reset the Polycom EagleEye Director using the restore button:



Be sure to keep the Polycom EagleEye Director powered on during the factory restore.

- 1 Press and hold the restore button on the back of the EagleEye Director for 2-3 seconds while the power light cycles.

When normal video content is displayed on the monitor instead of a blue screen, the EagleEye Director has been successfully restored.

- 2 Release the restore button.

How to Contact Technical Support

If you are not able to make test calls successfully and you have verified that the equipment is installed and set up correctly, contact your Polycom distributor or Polycom Technical Support.

To contact Polycom Technical Support, go to support.polycom.com.

Enter the following information, then ask a question or describe the problem. This information helps us to respond faster to your issue:

- The 14-digit serial number from the **System Detail** screen or the back of the system
- The software version from the **System Detail** screen
- Any active alerts generated by the system
- Information about your network
- Troubleshooting steps you have already tried

You can find the system detail information in the local interface by going to **System > Information** or in the web interface by clicking **System** in the blue bar at the top of the web interface page.

Polycom Solution Support

Polycom Implementation and Maintenance services provide support for Polycom solution components only. Additional services for supported third-party Unified Communications (UC) environments integrated with Polycom solutions are available from Polycom Global Services, and its certified Partners, to help customers successfully design, deploy, optimize, and manage Polycom visual communication within their third-party UC environments. UC Professional Services for Microsoft Integration is mandatory for Polycom Conferencing for Microsoft Outlook and Microsoft Office Communications Server or Microsoft Lync Server integrations. For additional information and details please refer to http://www.polycom.com/services/professional_services/index.html or contact your local Polycom representative.

System Back Panel Views

Polycom RealPresence Group 300 System

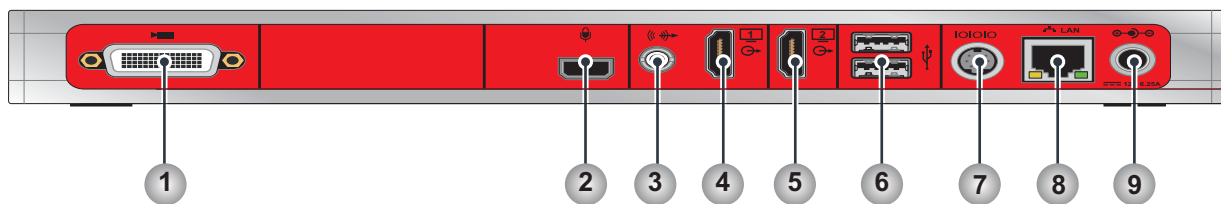

Reference Number	Input/Output	Supported Formats	Description
1	Video Input	HDCI	Input for the camera
2	Microphone Input	Polycom Microphone	Audio input for Polycom microphones or a SoundStation IP 7000 or Soundstructure mixer
3	Aux Audio Output	3.5mm Stereo	Audio output for main monitor audio or external speaker system System tones and sound effects + Audio from the far site +
4	Video Output 1	HDMI	Output for Monitor 1
5	Video Output 2	HDMI	Output for Monitor 2 (available only with a monitor option key)
6	USB Connectors	USB 2.0	USB for Software Update, remote control battery charge
7	Serial Port	RS-232	Serial port for integrator API
8	LAN Port	Ethernet	Connectivity for IP and SIP calls, People+Content IP, and the system's web interface
9	Power Input	12 V 6.25 A	Power input

Polycom RealPresence Group 500 System

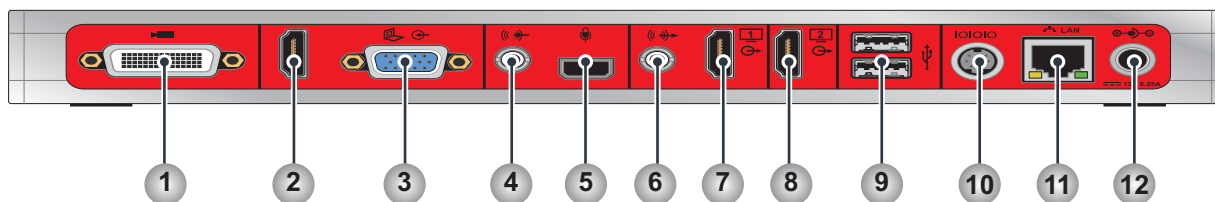

Reference Number	Input/Output	Supported Formats	Description
1	Video Input 1	HDCI	Input for Camera 1
2	Video Input 2/ Audio Input 1	HDMI	Video and audio input for Content Audio input 1 can be configured only as Content
3	Video Input 2	VGA	Video input for Content
Note: Use either the HDMI or VGA video input, but not both.			
4	Audio Input 2	3.5mm Stereo	Audio input for Content or microphone Can be configured as a separate line level analog microphone input
5	Microphone Input	Polycom Microphone	Audio input for Polycom microphones or a SoundStation IP 7000 or Soundstructure mixer
6	Audio Output 1	3.5mm Stereo	Audio output for main monitor audio or external speaker system Audio Mix Routed to the Output: System tones and sound effects + Audio from the far site + Content audio connected to audio input 3
7	Video Output 1 also carries audio	HDMI	Output for Monitor 1 Audio output for main monitor audio or external speaker system Audio Mix Routed to the Output: System tones and sound effects + Audio from the far site + Content audio connected to audio input 3
8	Video Output 2 video only	HDMI	Output for Monitor 2
9	USB Connectors	USB 2.0	USB for Software Update, remote control battery charge

Reference Number	Input/Output	Supported Formats	Description
10	Serial Port	RS-232	Serial port for integrator API
11	LAN Port	Ethernet	Connectivity for IP calls, People+Content IP, and the system's web interface
12	Power Input	12 V 6.25 A	Power input

Polycom RealPresence Group 700 System

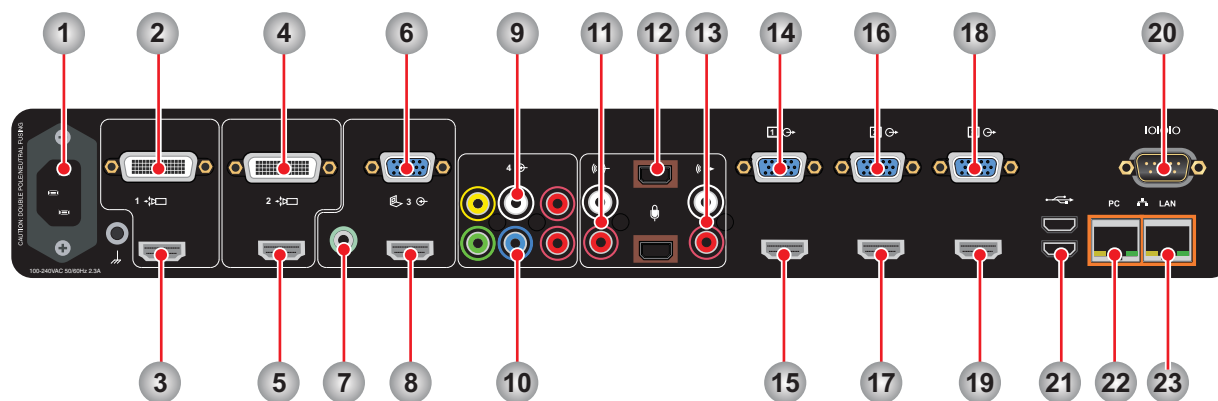

Reference Number	Input/Output	Supported Formats	Description
1	Power Input	100-240 VAC 2.3 A	Power input
2	Video Input 1	HDCI	Input for Camera 1
3	Video Input 1	HDMI	Input for Camera 1
4	Video Input 2	HDCI	Input for Camera 2
5	Video Input 2	HDMI	Input for Camera 2
Note: Use either the HDCI or HDMI for video inputs 1 and 2, but not both.			
6	Video Input 3	VGA	Video input for PC Content
7	Audio Input 3	3.5mm Stereo	Audio input for PC Content Associated with Video Input 3 (audio is disabled until camera 3 is selected) Audio is included in output 1.
8	Video Input 3	HDMI	Video and audio input for PC Content
Note: Use either the HDMI or VGA for video input 3, but not both.			
9	Video Input 4 Audio Input 4	Composite Video, RCA Audio	Video and audio input for VCR/DVD Content Associated with Video Input 4 (audio is disabled until camera 4 is selected)
10	Video Input 4	Component Video	Video and audio input for VCR/DVD Content
Note: Use either the Composite/RCA or Component for input 4, but not both.			
11	Audio Input 2	RCA	Auxiliary audio input Intended as microphone input; not included in audio mix of output 1

Reference Number	Input/Output	Supported Formats	Description
12	Audio Input 1	Polycom Microphone	Audio input for Polycom microphones or a SoundStation IP 7000 or Soundstructure mixer
13	Audio Output 2	RCA	Audio output for main monitor audio or external speaker system Audio Mix Routed to the Output: System tones and sound effects + Audio from the far site + Content audio connected to PC audio input
14	Video Output 1	VGA	Output for Monitor 1
15	Video Output 1 Audio Output 1	HDMI	Output for Monitor 1 Audio Mix Routed to the Output: System tones and sound effects + Audio from the far site + Content audio connected to PC audio input
16	Video Output 2	VGA	Output for Monitor 2
17	Video Output 2	HDMI	Output for Monitor 2
18	Video Output 3	VGA	Output for Monitor 3
19	Video Output 3	HDMI	Output for Monitor 3
Note: Use either the HDMI or VGA for video outputs 1, 2, and 3, but not both.			
20	Serial Port	RS-232	Serial port for integrator API
21	USB Connectors	USB 3.0	USB for Software Update, remote control battery charge
22	PC LAN Port	Ethernet	Pass-through Ethernet connector for providing IP to a connected computer
23	LAN Port	Ethernet	Connectivity for IP calls, People+Content IP, and the system's web interface

Call Speeds and Resolutions

Point-to-Point Dialing Speeds

The following table shows the maximum allowable H.323/SIP point-to-point dialing speeds for each system.

System	Maximum Call Speed
RealPresence Group 300	3072 kbps
RealPresence Group 500	6144 kbps
RealPresence Group 700	6144 kbps

Multipoint Dialing Speeds

The following table shows the maximum allowable H.323/SIP dialing speeds for the number of sites in a call. Maximum speeds can be further limited by the communications equipment. Multipoint option keys are required for some of the capabilities shown in the table.

Number of Sites in Call	Max Speed for Each Site	Max Speed for Each Site (ICE Enabled, Lync/OCS R2)	Max Speed for Each Site (CCCP Lync with A/V MCU)
3	3072 kbps	1024 kbps	664 kbps
4	2048 kbps	512 kbps	664 kbps
5	1536 kbps	384 kbps	664 kbps

Number of Sites in Call	Max Speed for Each Site	Max Speed for Each Site (ICE Enabled, Lync/OCS R2)	Max Speed for Each Site (CCCP Lync with A/V MCU)
6	1152 kbps	256 kbps	664 kbps
7 (RealPresence Group 700 only)	1024 kbps	128 kbps	664 kbps
8 (RealPresence Group 700 only)	832 kbps	128 kbps	664 kbps

Call Speeds and Resolutions

The following illustrations show the resolution and frame rate sent in a call, depending on the speed of the call and the **Optimized for** setting of your Camera input. The values for sharpness and motion are the same from 4 MB to 6 MB for systems that support higher call speeds.

The difference between NTSC and PAL cameras is how frame rates are calculated:

- NTSC 60 fps equals PAL 50 fps
- NTSC 30 fps equals PAL 25 fps

The following table shows the resolutions for People video on RealPresence Group systems with NTSC cameras in H.264 High Profile calls.

		Camera Source					
		SD (720x480x60)		HD (1280x720x60)		HD (1920x1080x60)	
Call Speed (kbps)	Motion/Sharpness	Resolution	Max Frame Rate (fps)	Resolution	Max Frame Rate (fps)	Resolution	Max Frame Rate (fps)
<512	Motion	352x240	60	512x288	60	512x288	60
512-639	Motion	704x480	60	768x448	60	768x448	60
640-831	Motion	704x480	60	1024x576	60	1024x576	60
831-1727	Motion	704x480	60	1280x720	60	1280x720	60
>=1728	Motion	704x480	60	1280x720	60	1920x1080	60
< 128	Sharpness	352x240	30	512x288	30	512x288	30
128-383	Sharpness	704x480	30	768x448	30	768x448	30
384-511	Sharpness	704x480	30	1024x576	30	1024x576	30

		Camera Source					
		SD (720x480x60)		HD (1280x720x60)		HD (1920x1080x60)	
Call Speed (kbps)	Motion/Sharpness	Resolution	Max Frame Rate (fps)	Resolution	Max Frame Rate (fps)	Resolution	Max Frame Rate (fps)
512-1023	Sharpness	704x480	30	1280x720	30	1280x720	30
1024-2047	Sharpness	704x480	30	1280x720	30	1920x1080	30
>=2048	Sharpness	704x480	30	1280x720	30	1920x1080	60

The following table shows the resolutions for People video on RealPresence Group systems with NTSC cameras in H.264 Baseline Profile calls.

		Camera Source					
		SD (720x480x60)		HD (1280x720x60)		HD (1920x1080x60)	
Call Speed (kbps)	Motion/Sharpness	Resolution	Max Frame Rate (fps)	Resolution	Max Frame Rate (fps)	Resolution	Max Frame Rate (fps)
<768	Motion	352x240	60	512x288	60	512x288	60
768-959	Motion	704x480	60	768x448	60	768x448	60
960-1231	Motion	704x480	60	1024x576	60	1024x576	60
1232-3071	Motion	704x480	60	1280x720	60	1280x720	60
>=3072	Motion	704x480	60	1280x720	60	1920x1080	60
< 128	Sharpness	352x240	30	512x288	30	512x288	30
128-575	Sharpness	704x480	30	768x448	30	768x448	30
576-831	Sharpness	704x480	30	1024x576	30	1024x576	30
832-1727	Sharpness	704x480	30	1280x720	30	1280x720	30
1728-3455	Sharpness	704x480	30	1280x720	30	1920x1080	30
>=3456	Sharpness	704x480	30	1280x720	30	1920x1080	60

Resolution and Frame Rates for Content Video

The high frame rates with high resolution apply only to point-to-point calls above 832 kbps. In addition, you must set **Optimized for** value of your Camera input to **Sharpness**. Low frame rates apply if your call does not meet these requirements.

For multipoint calls, the maximum resolution and frame rate for content is 720p @ 30 fps.

Resolution	Encode Resolution	Sharpness	Motion
800 x 600	800 x 600	30	60
1024 x 768	1024 x 768	30	60
1280 x 720	1280 x 720	30	60
1280 x 768	1280 x 720	30	60
1280 x 1024	1280 x 1024	30	60
1600 x 1200	1280 x 720	30	60
1680 x 1050	1280 x 720	30	60
1920 x 1080	1920 x 1080	30	60*
1920 x 1200	1920 x 1080	30	60*

*Available only when the **Quality Preference** setting on your RealPresence Group 500 is set to **Content Stream** in **Admin Settings > Network > IP Network > Network Quality**.