



---

# Integrator's Reference Manual for the VSX Series



## Trademark Information

Polycom®, the Polycom logo design, and Vortex® are registered trademarks of Polycom, Inc., and Conference on Demand™, Global Management System™, PathNavigator™, People+Content™, PowerCam™, Pro-Motion™, Siren™ 14, Visual Concert™, and VSX™ are trademarks of Polycom, Inc. in the United States and various other countries. All other trademarks are the property of their respective owners.

## Patent Information

The accompanying product are protected by one or more U.S. and foreign patents and/or pending patent applications held by Polycom, Inc.

© 2004 Polycom, Inc. All rights reserved.

Polycom Inc.  
4750 Willow Road  
Pleasanton, CA 94588-2708  
USA

No part of this document may be reproduced or transmitted in any form or by any means, electronic or mechanical, for any purpose, without the express written permission of Polycom, Inc. Under the law, reproducing includes translating into another language or format.

As between the parties, Polycom, Inc. retains title to, and ownership of, all proprietary rights with respect to the software contained within its products. The software is protected by United States copyright laws and international treaty provision. Therefore, you must treat the software like any other copyrighted material (e.g. a book or sound recording).

Every effort has been made to ensure that the information in this manual is accurate. Polycom, Inc. is not responsible for printing or clerical errors. Information in this document is subject to change without notice.

# Contents

---

## Chapter 1 - Cables

Network Cables .....	1 - 1
LAN Cable .....	1 - 1
ISDN Cable .....	1 - 2
Analog Telephone (POTS) Cable .....	1 - 3
V.35/RS-449/RS-530 Adapter .....	1 - 4
V.35 Cable .....	1 - 5
V.35 and RS-366 Serial Cable .....	1 - 6
RS-449 and RS-366 Serial Cable .....	1 - 7
RS-530 with RS-366 Serial Cable .....	1 - 8
Video and Camera Cables .....	1 - 9
S-Video Cable .....	1 - 9
BNC to S-Video Cable .....	1 - 10
BNC to S-Video Adapter .....	1 - 11
VCR/DVD Composite Cable .....	1 - 12
VGA Cable .....	1 - 13
Composite Video Cable .....	1 - 14
PowerCam Plus Primary Cable .....	1 - 15
PowerCam Primary Cable .....	1 - 16
PowerCam Secondary Break-Out Cable .....	1 - 17
PowerCam Secondary Control Cable (VSX 8000) .....	1 - 18
PowerCam Secondary Control Cable (VSX 7000) .....	1 - 19
S-Video to RCA Adapter .....	1 - 20
Audio Cables .....	1 - 21
Conference Link Cable .....	1 - 21
Audio Cable .....	1 - 23
Vortex Cable .....	1 - 24
VSX to VTX Cable .....	1 - 25
Visual Concert to VSX Cable .....	1 - 26
Serial (RS-232) Cables .....	1 - 27
RS-232 Cable (VSX 7000) .....	1 - 27
RS-232 Cable (VSX 8000) .....	1 - 29
RS-232 Adapter .....	1 - 30
Null Modem Cable .....	1 - 31
Null Modem Adapter .....	1 - 32
Content Sharing Cables .....	1 - 33
Visual Concert VSX Cable .....	1 - 33
ImageShare II to PC Cable .....	1 - 34

## Chapter 2 - Using the API

Using the API with an RS-232 Interface .....	2 - 1
Configuring the RS-232 Interface .....	2 - 1
Starting an API Session via an RS-232 Interface .....	2 - 2
Using the API with a LAN Connection .....	2 - 2

## Chapter 3 - System Commands

Syntax Conventions .....	3 - 2
Alphabetical List of Commands .....	3 - 3
API Commands .....	3 - 11
Audio Commands .....	3 - 16
Call Commands .....	3 - 20
Camera Control Commands .....	3 - 39
Diagnostics and Statistics Commands .....	3 - 42
IP Commands .....	3 - 58
ISDN Commands .....	3 - 69
Peripherals Commands .....	3 - 84
Polycom Tools Commands .....	3 - 88
Security and Permissions Commands .....	3 - 107
Video Commands .....	3 - 110

## Appendix

Status Display .....	Appendix - 1
B Channel Status Message Example .....	Appendix - 1

# 1 Cables

## Network Cables

### LAN Cable

This cable connects a VSX system to the LAN.

Description	Used With	Part Number	Length
Orange RJ-45 connectors on both ends 	VSX 3000 VSX 7000 VSX 8000	2457-08343-001	Shipped Length: 12 ft (3.6 m) Maximum Approved Length: 100 ft (30 m)

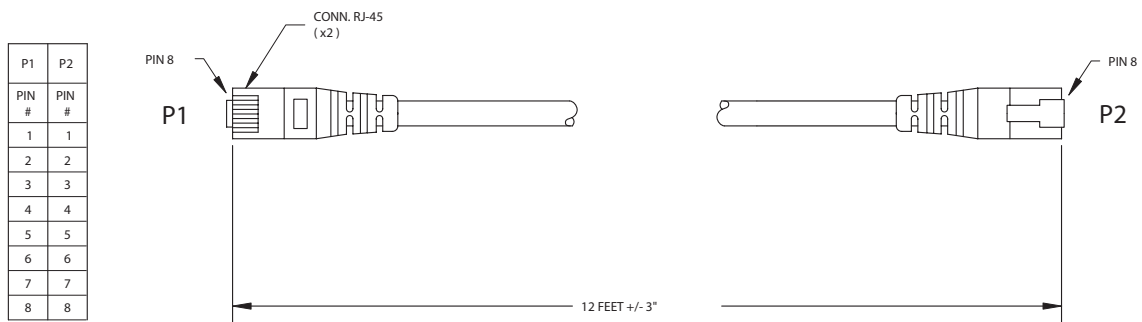

This drawing is provided for design reference only. Polycom claims no responsibility or liability for the quality, performance and/or reliability of cables based on this reference drawing. Cables are available from Polycom that meet the appropriate manufacturing tolerances, quality and performance parameters.

## ISDN Cable

This cable connects a VSX system to a BRI or PRI line.

Description	Used With	Part Number	Length
Clear RJ-45 connectors on both ends 	VSX 3000 VSX 7000 VSX 8000	2457-08548-001	Shipped Length: 20 ft (6.6 m) Maximum Approved Length: 50 ft (15 m)

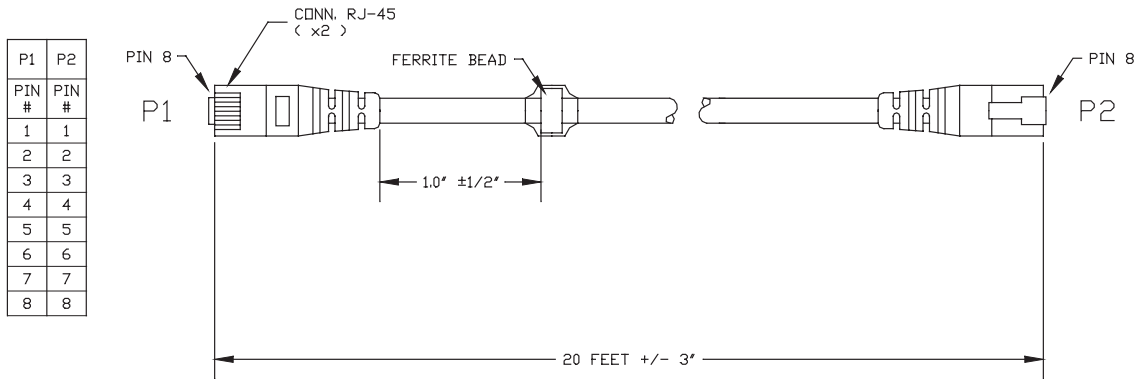

This drawing is provided for design reference only. Polycom claims no responsibility or liability for the quality, performance and/or reliability of cables based on this reference drawing. Cables are available from Polycom that meet the appropriate manufacturing tolerances, quality and performance parameters.

## Analog Telephone (POTS) Cable

This cable connects a VSX 8000 to an analog telephone.

Description	Used With	Part Number	Length
Pink RJ-11 connectors on both ends 	VSX 8000	2457-20071-001	Shipped Length: 12 ft (3.6 m) Maximum Approved Length: 100 ft (30 m)

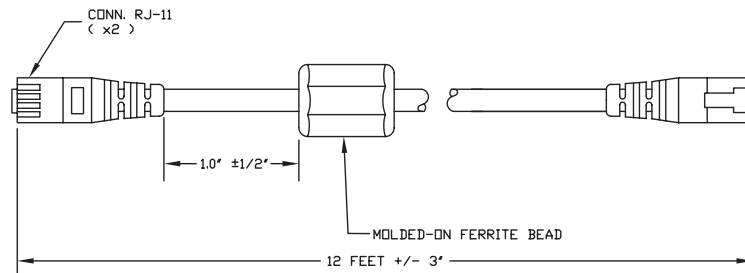

WIRING IS "PIN TO PIN" 1-1, 2-2, ETC.



This drawing is provided for design reference only. Polycom claims no responsibility or liability for the quality, performance and/or reliability of cables based on this reference drawing. Cables are available from Polycom that meet the appropriate manufacturing tolerances, quality and performance parameters.

## V.35/RS-449/RS-530 Adapter

This adapter is used when connecting a VSX system to V.35 or other third-party network equipment.

Description	Used With	Part Number	Length
68-pin to 44-pin 	VSX 7000 VSX 8000	2457-21264-001	Shipped Length: 6 in (15.23 cm)

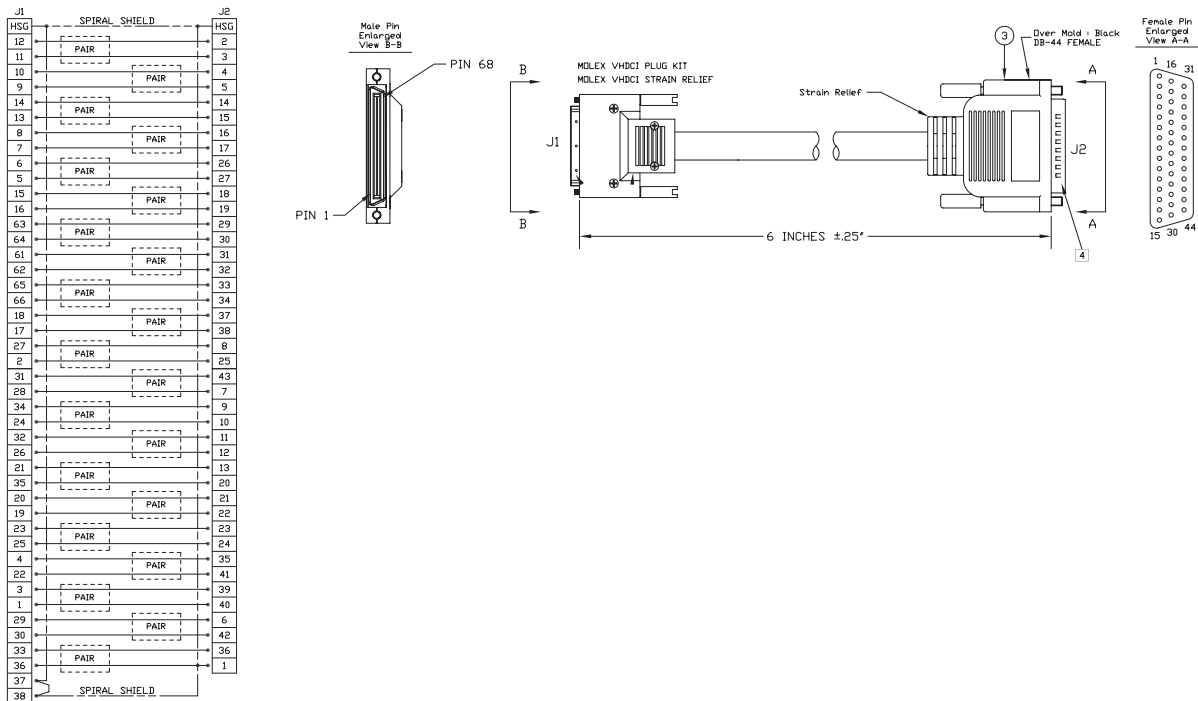

This drawing is provided for design reference only. Polycom claims no responsibility or liability for the quality, performance and/or reliability of cables based on this reference drawing. Cables are available from Polycom that meet the appropriate manufacturing tolerances, quality and performance parameters.



## V.35 Cable

This cable connects a VSX system to third-party network equipment via the V.35 adapter (2457-21264-001).

Description	Used With	Part Number	Length
HD-44 M connectors on both ends	VSX 7000 VSX 8000	2457-10608-001	Shipped Length: 5 ft (1.65 m)

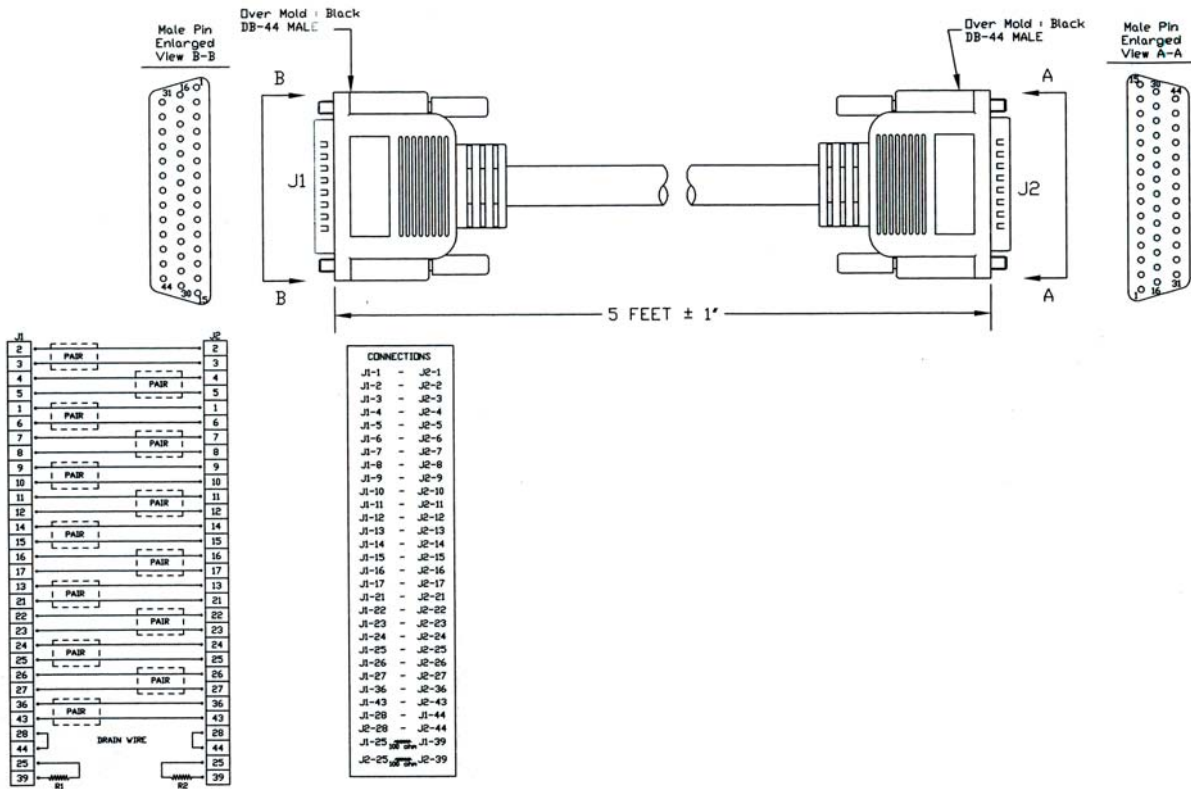

This drawing is provided for design reference only. Polycom claims no responsibility or liability for the quality, performance and/or reliability of cables based on this reference drawing. Cables are available from Polycom that meet the appropriate manufacturing tolerances, quality and performance parameters.

## V.35 and RS-366 Serial Cable

This cable connects a VSX system to third-party network equipment via the V.35 adapter (2457-21264-001).

Description	Used With	Part Number	Length
HD-44 M to "Y" Winchester 34M/RS-366	VSX 7000 VSX 8000	2457-10609-001	Shipped Length: 5 ft (1.65 m)

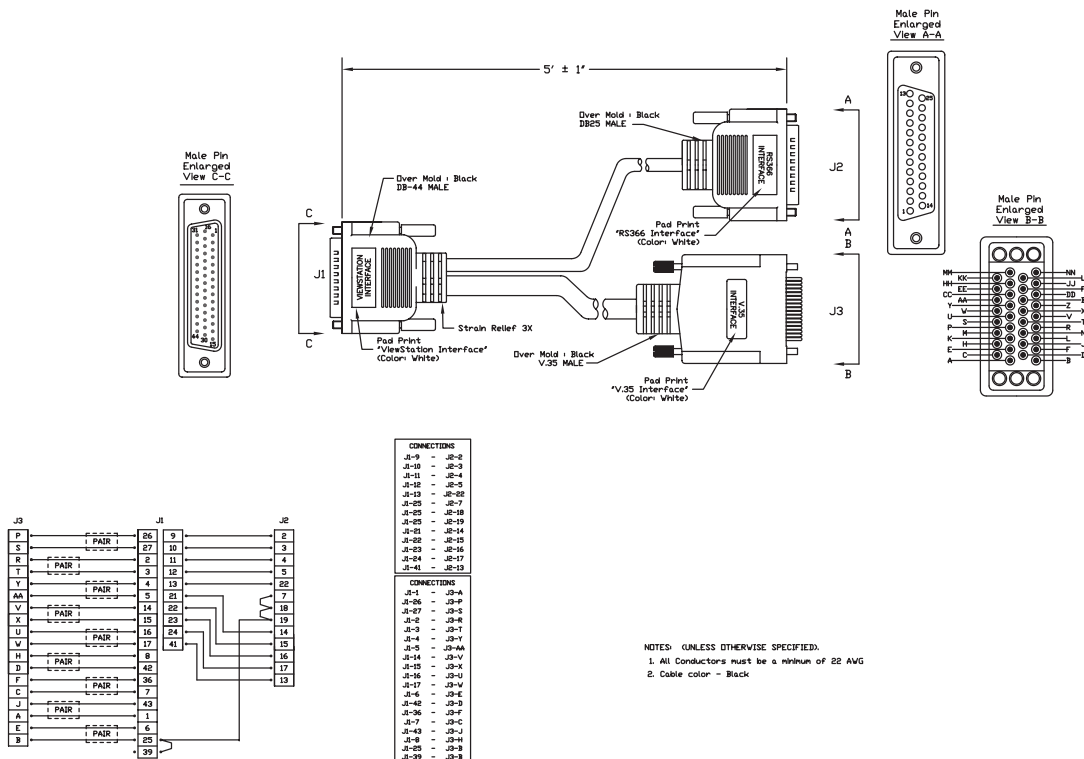

This drawing is provided for design reference only. Polycom claims no responsibility or liability for the quality, performance and/or reliability of cables based on this reference drawing. Cables are available from Polycom that meet the appropriate manufacturing tolerances, quality and performance parameters.

## RS-449 and RS-366 Serial Cable

This cable connects a VSX system to third-party network equipment via the V.35 adapter (2457-21264-001).

Description	Used With	Part Number	Length
HD-44 M to "Y" RS-449 DB-37M/RS-366 DB-25M	VSX 7000 VSX 8000	2457-10610-001	Shipped Length: 5 ft (1.65 m)

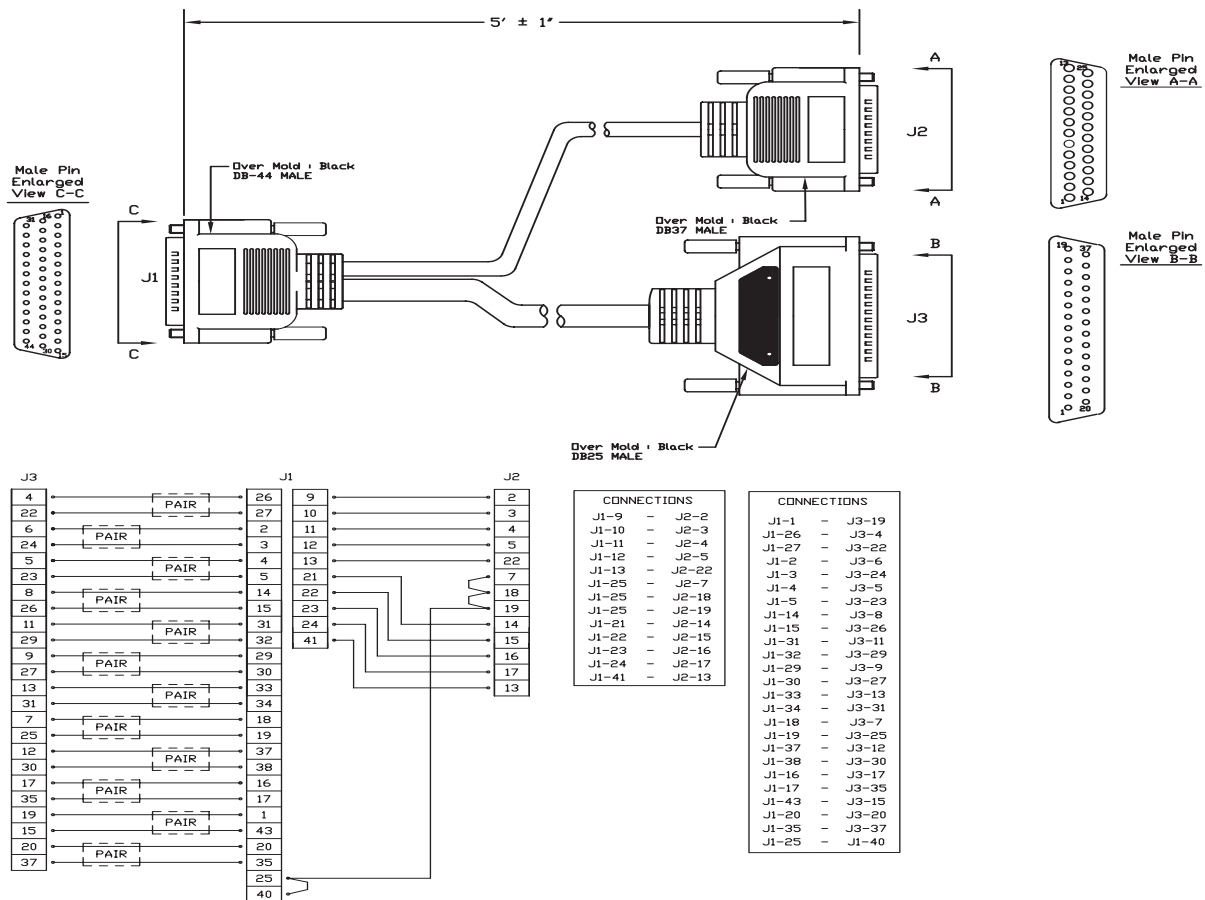

This drawing is provided for design reference only. Polycom claims no responsibility or liability for the quality, performance and/or reliability of cables based on this reference drawing. Cables are available from Polycom that meet the appropriate manufacturing tolerances, quality and performance parameters.

## RS-530 with RS-366 Serial Cable

This cable connects a VSX system to third-party network equipment.

Description	Used With	Part Number	Length
HD-68M to "Y" RS-530 DB-37M/RS-366 DB-25M	VSX 7000 VSX 8000	2457-21263-001	Shipped Length: 5 ft (1.65 m)

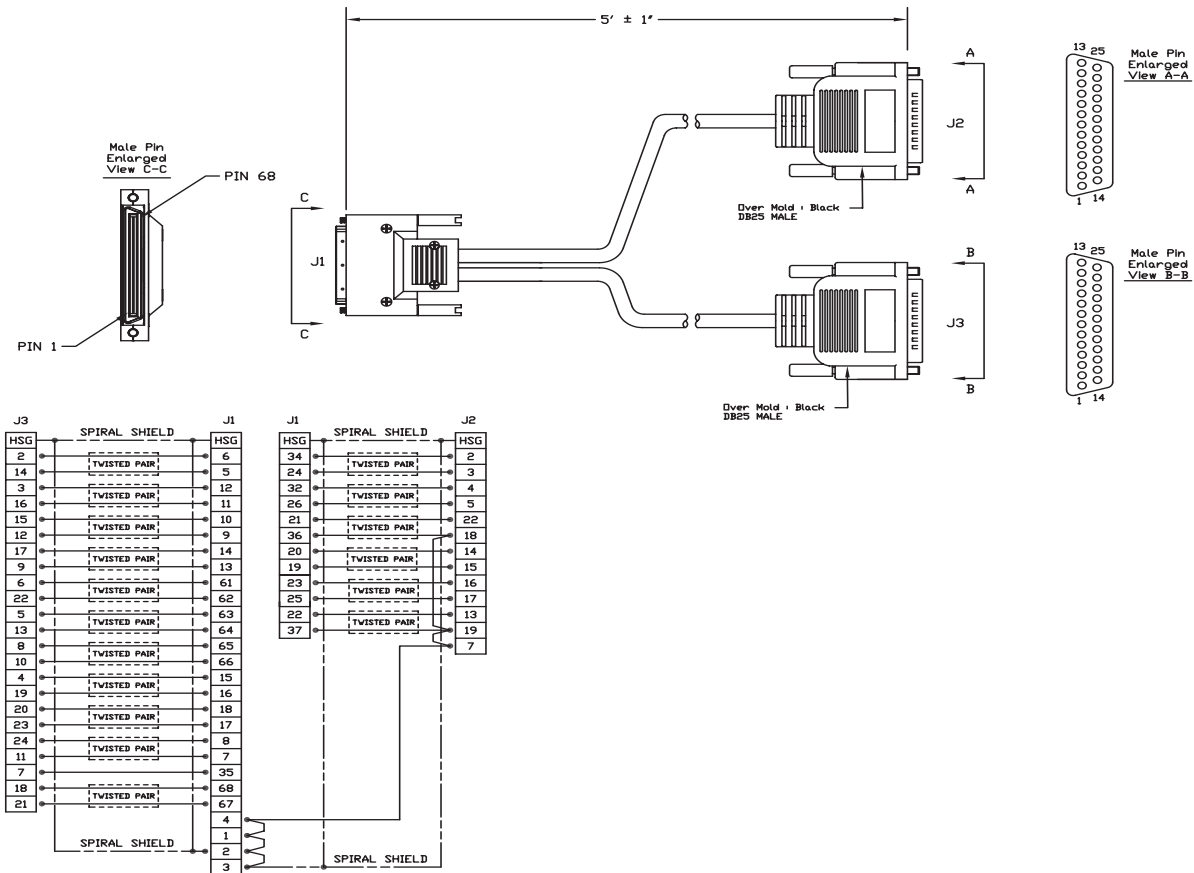

This drawing is provided for design reference only. Polycom claims no responsibility or liability for the quality, performance and/or reliability of cables based on this reference drawing. Cables are available from Polycom that meet the appropriate manufacturing tolerances, quality and performance parameters.

# Video and Camera Cables

## S-Video Cable

The S-video cable connects a VSX system to a monitor or camera.

Description	Used With	Part Number	Length	Other Cables Available
Yellow 4-pin mini-DIN connectors on both ends 	VSX 3000 VSX 7000 VSX 8000 (may require BNC adapter)	2457-08409-001	Shipped Length: 25 ft (7.6 m) Maximum Approved Length: 50 ft (15 m)	2457-09204-001 50 ft (15 m)

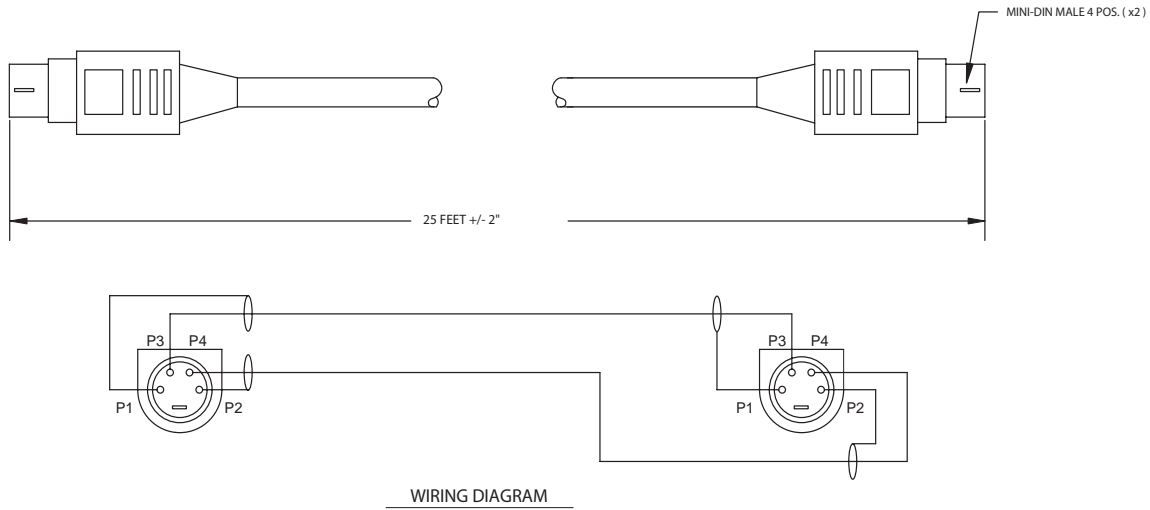

This drawing is provided for design reference only. Polycom claims no responsibility or liability for the quality, performance and/or reliability of cables based on this reference drawing. Cables are available from Polycom that meet the appropriate manufacturing tolerances, quality and performance parameters.

## BNC to S-Video Cable

Use this cable to connect S-video devices to a VSX 8000 system.

Description	Used With	Part Number	Length
4-pin mini-DIN to dual BNC 	VSX 8000	2457-21489-001	Shipped Length: 6 ft (1.8 m)

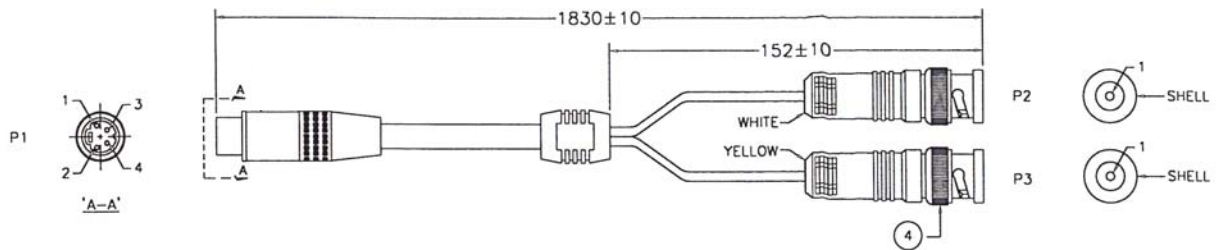

WIRING DIAGRAM

COLOR	P1		P2
WHITE	POS 3	---	POS 1
SPIRAL SHIELD	POS 1	---	SHELL
BLACK	POS 4	---	P3
SPIRAL SHIELD	POS 2	---	POS 1
			SHELL



This drawing is provided for design reference only. Polycom claims no responsibility or liability for the quality, performance and/or reliability of cables based on this reference drawing. Cables are available from Polycom that meet the appropriate manufacturing tolerances, quality and performance parameters.

## BNC to S-Video Adapter

This adapter may be required when connecting standard S-video cables to a VSX 8000.

Description	Used With	Part Number	Length
Dual BNC to 4-pin mini-DIN 	VSX 8000	2457-21490-001	Shipped Length: 1 ft (.33 m)

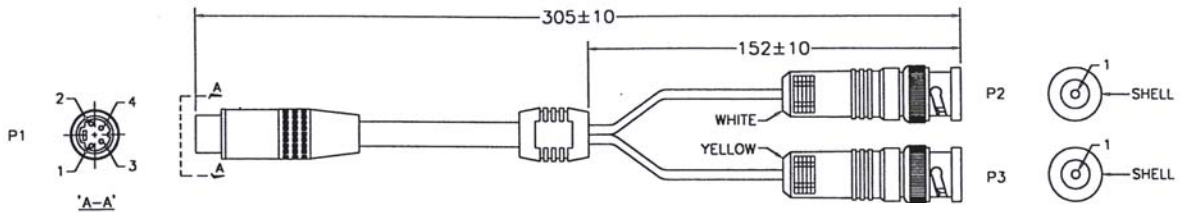

WIRING DIAGRAM

COLOR	P1		P2
WHITE	POS 3	---	POS 1
SPIRAL SHIELD	POS 1	---	SHELL
		---	
BLACK	POS 4	---	P3
SPIRAL SHIELD	POS 2	---	POS 1
		---	*SHELL



This drawing is provided for design reference only. Polycom claims no responsibility or liability for the quality, performance and/or reliability of cables based on this reference drawing. Cables are available from Polycom that meet the appropriate manufacturing tolerances, quality and performance parameters.

## VCR/DVD Composite Cable

This cable connects a VSX system to a VCR or DVD player.

Description	Used With	Part Number	Length
Triple RCA connectors on both ends 	VSX 3000 VSX 7000 VSX 8000 (requires RCA to 4-pin mini-DIN adapter)	2457-08412-001	Shipped Length: 8 ft (2.6 m) Maximum Approved Length: 50 ft (15 m)

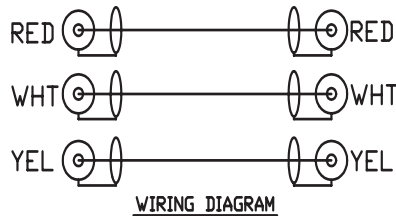
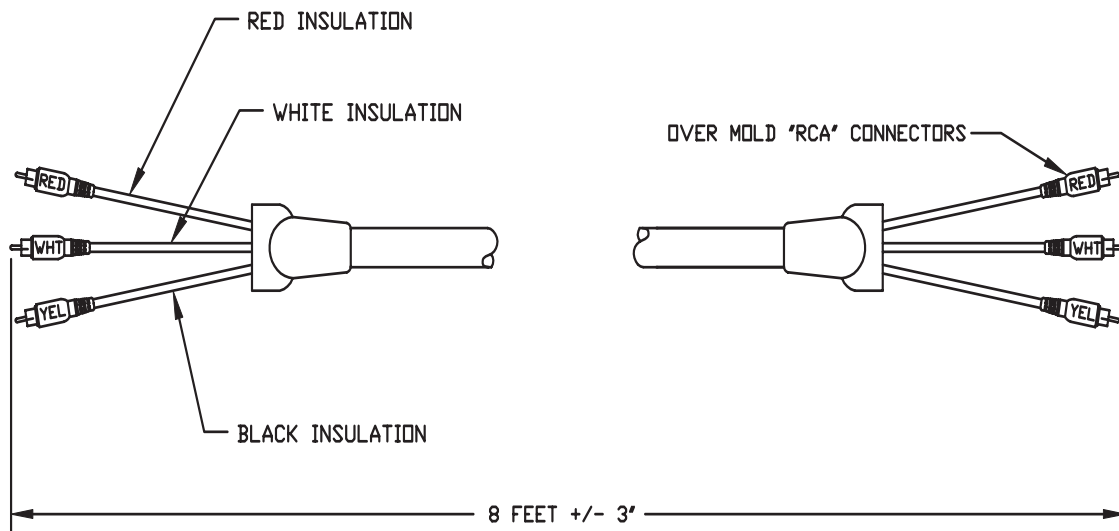

This drawing is provided for design reference only. Polycom claims no responsibility or liability for the quality, performance and/or reliability of cables based on this reference drawing. Cables are available from Polycom that meet the appropriate manufacturing tolerances, quality and performance parameters.



## VGA Cable

This cable connects a VSX system to a VGA monitor.

Description	Used With	Part Number	Length
HD-15 high-density subminiature connectors on both ends 	VSX 7000 (use with additional display adapter) VSX 8000	2457-09211-001	Shipped Length: 30 ft (9.1 m)

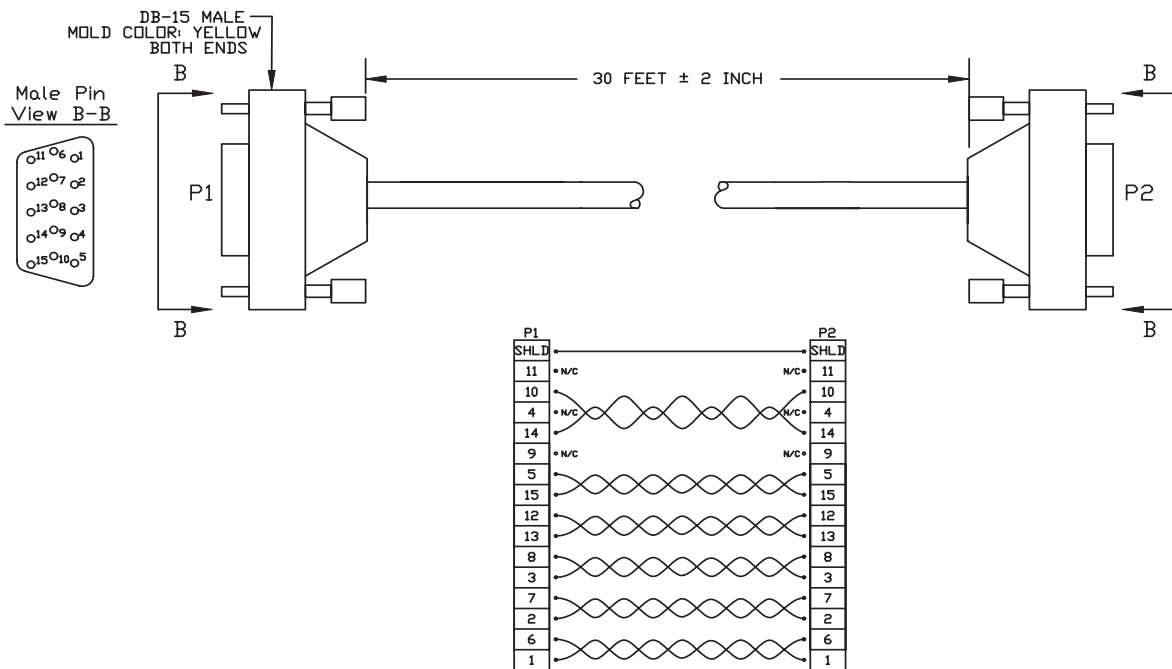

This drawing is provided for design reference only. Polycom claims no responsibility or liability for the quality, performance and/or reliability of cables based on this reference drawing. Cables are available from Polycom that meet the appropriate manufacturing tolerances, quality and performance parameters.

## Composite Video Cable

This cable connects a VSX 7000 or VSX 8000 to a monitor or camera.

Description	Used With	Part Number	Length
Single yellow RCA connector on both ends 	VSX 7000 VSX 8000 (requires composite adapter)	2457-09207-001	Shipped Length: 25 ft (7.6 m) Maximum Approved Length: 100 ft (30 m)

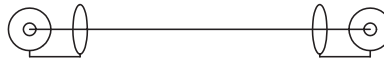
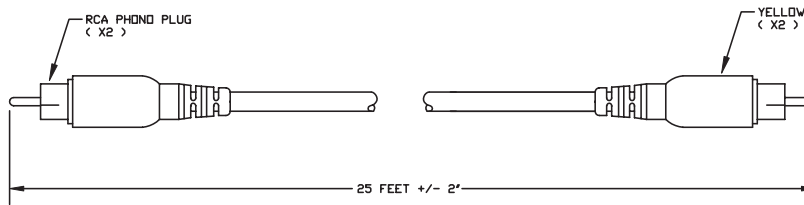

WIRING DIAGRAM



This drawing is provided for design reference only. Polycom claims no responsibility or liability for the quality, performance and/or reliability of cables based on this reference drawing. Cables are available from Polycom that meet the appropriate manufacturing tolerances, quality and performance parameters.

## PowerCam Plus Primary Cable

This cable connects a VSX 8000 to a PowerCam Plus camera.

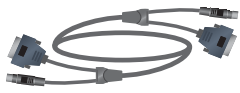
Description	Used With	Part Number	Length
4-pin mini-DIN and DB-15 on both ends 	VSX 8000 (requires S-Video to BNC adapter, requires DB-15 to DB-9 adapter if used for a secondary camera)	1457-50105-001	Shipped Length: 9 ft 10 in (3 m)

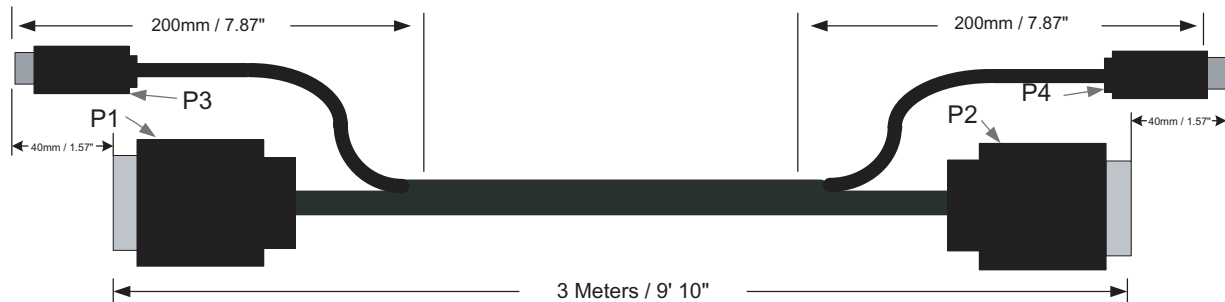

P1 Connector			P2 Connector		
Pin #	Signal Name		Pin #	Signal Name	
1	Arm Mic		1	Arm Mic	
2	Left Mic		2	Left Mic	
3	A GND		3	A GND	
4	Cam ID Bit		4	Cam ID Bit	
5	P GND		5	P GND	
6	+12V		6	+12V	
7	SW-RX/SN-TX		7	SW-RX/SN-TX	
8	IR signal		8	IR signal	
9	Center Mic		9	Center Mic	
10	Right Mic		10	Right Mic	
11	A GND		11	A GND	
12	P GND		12	P GND	
13	+12V		13	+12V	
14	SW-TX/SN-RX		14	SW-TX/SN-RX	
15	IR return		15	IR return	
P3 4 Pin mini Din			P4 4 Pin mini Din		
1	A GND		1	A GND	
2	A GND		2	A GND	
3	Luma		3	Luma	
4	Chroma		4	Chroma	



Front View of Connector





Front View of Connector





This drawing is provided for design reference only. Polycom claims no responsibility or liability for the quality, performance and/or reliability of cables based on this reference drawing. Cables are available from Polycom that meet the appropriate manufacturing tolerances, quality and performance parameters.

## PowerCam Primary Cable

This cable connects a VSX 8000 to a PowerCam camera up to 10 ft away.

Description	Used With	Part Number	Length
8-pin mini-DIN to 4-pin mini-DIN and DB-15 	VSX 8000 (requires S-Video to BNC adapter, requires DB-15 to DB-9 adapter if used for a secondary camera)	1457-50338-001	Shipped Length: 9 ft 10 in (3 m) Maximum Approved Length: 10 ft (3 m). Use Secondary Break-Out cable and power supply 300-0013-01 in conjunction with a PowerCam Secondary Control cable to get approved runs more than 10 ft.

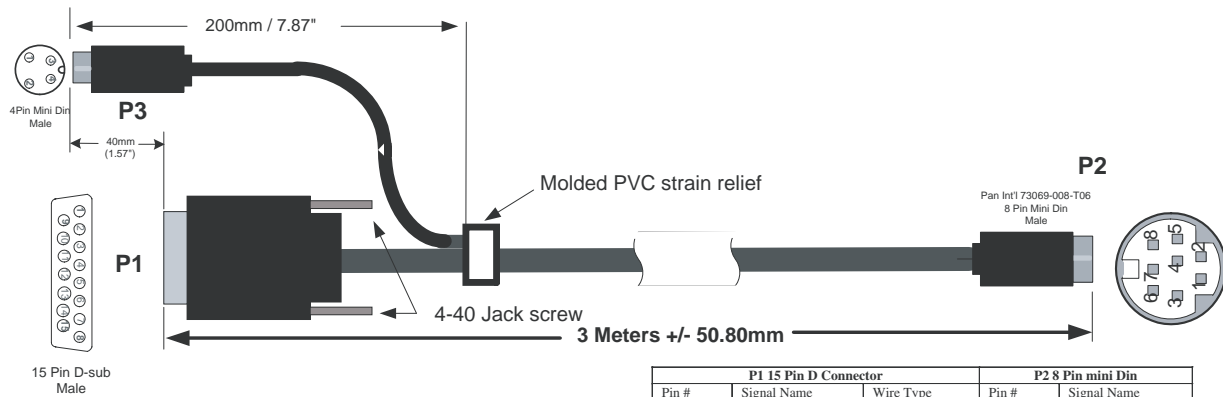

P1 15 Pin D Connector			P2 8 Pin mini Din	
Pin #	Signal Name	Wire Type	Pin #	Signal Name
1-4	N/C			
5	PGND	22AWG wire	3	DGND
6	+12V	22 AWG wire	7	+12V
7	SW-RX/SN-TX	30 AWG wire	2	SW-RX/SN-TX
8	IR-SIGNAL	30 AWG wire	4	IR_SIGNAL
9-11	N/C			
12	P GND	22 AWG wire	3	DGND
13	+12V	22 AWG wire	7	+12V
14	SW-TX/SN-RX	30 AWG wire	1	SW-TX/SN-RX
15	IR RETURN	30 AWG wire	3	DGND
	SHIELD	DRAIN wire		SHIELD
P3 4 Pin Mini Din				
1	RTN	Coax Shield	5	GVID
2	RTN	Coax Shield	5	GVID
3	Luma	Micro Coax	6	Luma
4	Chroma	Micro Coax	8	Chroma
	SHIELD	DRAIN wire		SHIELD



This drawing is provided for design reference only. Polycom claims no responsibility or liability for the quality, performance and/or reliability of cables based on this reference drawing. Cables are available from Polycom that meet the appropriate manufacturing tolerances, quality and performance parameters.

## PowerCam Secondary Break-Out Cable

This cable connects S-video and secondary control cables and a power supply to a PowerCam camera. This combination is required to use a PowerCam as either the primary or secondary camera for distances more than 10 ft away.

Description	Used With	Part Number	Length
8-pin mini-DIN to 3-way breakout block	VSX 7000 (use with S-video cable and PTZ cable, 2457-21712-001) VSX 8000 (use with control cable 1457-50527-001 and S-Video cable) Separate power supply required (part number 300-0013-01)	1457-50526-001	Shipped Length: 6 ft (1.8 m)

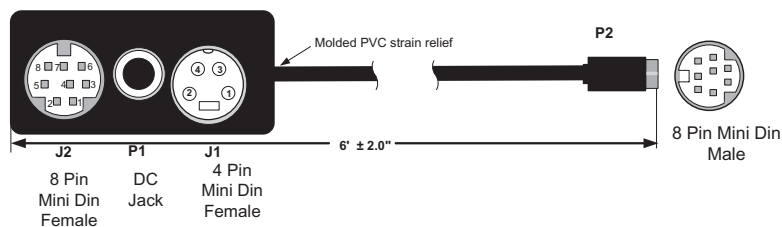

Mounting Hole	Molded Conn.Pin	Signal Name	Wire Type	P2 Pin #	Signal Name
MH6	J2.5	VCS TXD / CAM RXD	30 AWG wire	1	TXD
MH8	J2.3	VCS RXD / CAM TXD	30 AWG wire	2	RXD
MH10	2.6&4 P1.1	GND 2	2 AWG wire	3	DGND
MH11	2.6&4 P1.1	GND 2	2 AWG wire	3	DGND
MH5	J 2.7	IR_SIG	30 AWG wire	4	IR-SIGNAL
MH4	J1.1	Chroma Return	Coax Shield	5	AGND
MH1	J1.2	Luma Return	Coax Shield	5	AGND
MH3	J1.3	Luma (Y)	Micro Coax	6	Luma
MH7	P1.2	+12V	22 AWG wire	7	+12V
MH9	P 1.2	+12V	22 AWG wire	7	+12V
MH2	J1.4	Chroma (C)	Micro Coax	8	Chroma
J2	SHIELD		DRAIN wire	SHIELD	



This drawing is provided for design reference only. Polycom claims no responsibility or liability for the quality, performance and/or reliability of cables based on this reference drawing. Cables are available from Polycom that meet the appropriate manufacturing tolerances, quality and performance parameters.

## PowerCam Secondary Control Cable (VSX 8000)

This cable connects a VSX 8000 to a D30 or D100 camera VISCA port, or to a Break-Out cable that is also connected to a PowerCam camera and a power supply. This combination is required for distances more than 10 ft away.

Description	Used With	Part Number	Length
8-pin mini-DIN to DB-15	VSX 8000 (requires DB-15 to DB-9 adapter if used for a secondary camera)	1457-50527-001	Shipped Length: 50 ft (15 m)

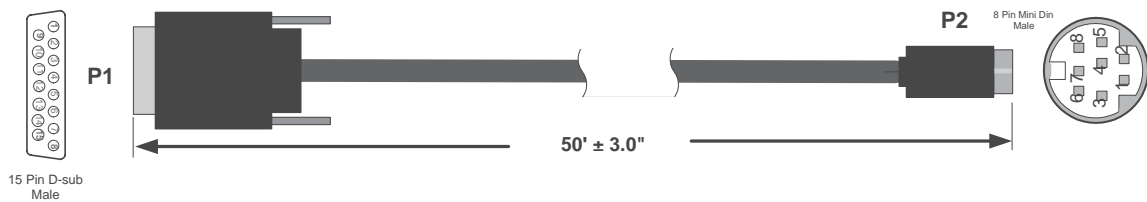

P1 15 Pin D Connector		P2 VISCA 8 Pin mini Din	
Pin #	Signal Name	Pin #	Signal Name
1-6, 9-11, 13	NC	1, 2, 8	NC
7	SW-RX/SN-TX	3	SW-RX/SN-TX
8	IR-SIGNAL	7	IR OUT
12	P-GND	4	GND
14	SW-TX/SN-RX	5	SW-TX/SN-RX
15	IR RETURN	6	GND
SHIELD		SHIELD	



This drawing is provided for design reference only. Polycom claims no responsibility or liability for the quality, performance and/or reliability of cables based on this reference drawing. Cables are available from Polycom that meet the appropriate manufacturing tolerances, quality and performance parameters.

## PowerCam Secondary Control Cable (VSX 7000)

This cable connects a VSX 7000 to the secondary break-out cable of a PowerCam camera. An S-video cable is also required.

Description	Used With	Part Number	Length
8-pin mini-DIN on both ends 	VSX 7000	2457-21713-001	Shipped Length: 25 ft (7.6 m)

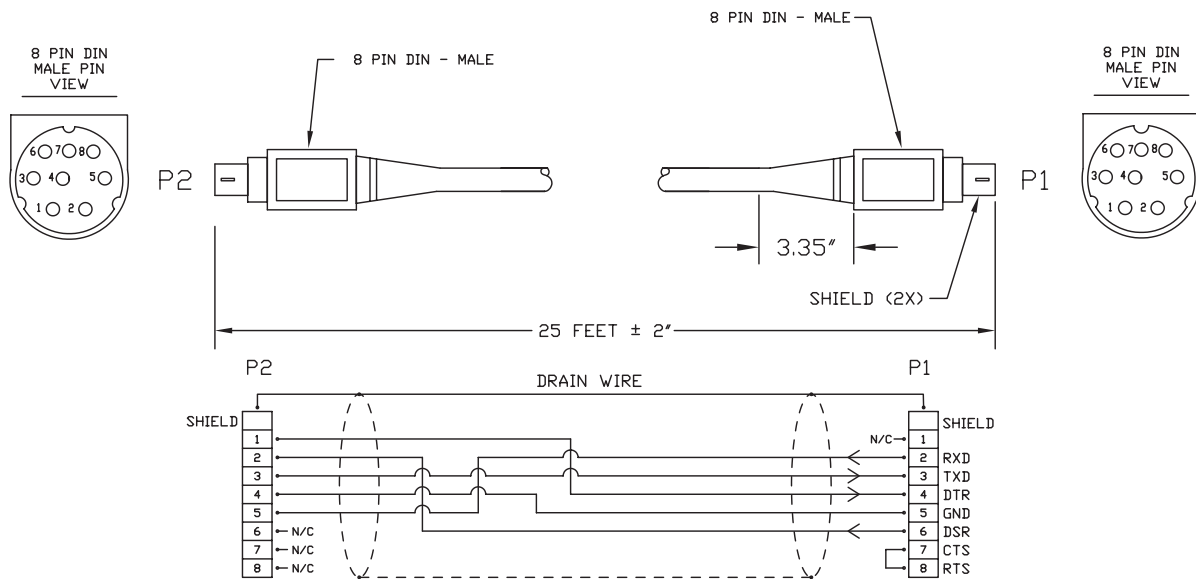

This drawing is provided for design reference only. Polycom claims no responsibility or liability for the quality, performance and/or reliability of cables based on this reference drawing. Cables are available from Polycom that meet the appropriate manufacturing tolerances, quality and performance parameters.

## S-Video to RCA Adapter

This adapter is used when connecting a standard composite video cable (or the video jack on a VCR cable) into an S-Video connector on a VSX 8000.

Description	Used With	Part Number	Length
Yellow RCA to 4-pin mini-DIN	VSX 8000	1517-08822-002	Shipped Length: 2 in

WIRE LIST:	
P1-3	→ J1-CENTER
P1-4	→ N.C.
P1-1	→ P1-2 → J1-SHIELD
P1-SHIELD	→ N.C.

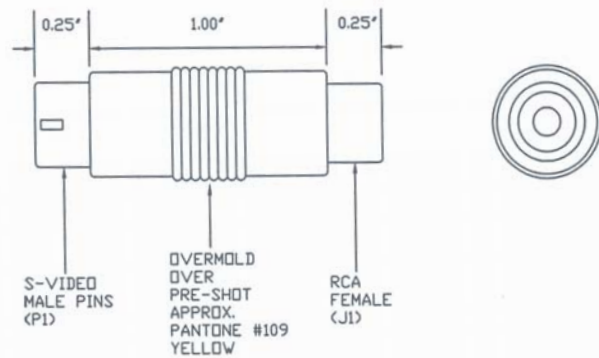

This drawing is provided for design reference only. Polycom claims no responsibility or liability for the quality, performance and/or reliability of cables based on this reference drawing. Cables are available from Polycom that meet the appropriate manufacturing tolerances, quality and performance parameters.



# Audio Cables

## Conference Link Cable

These cables connect a VSX system to a microphone pod or Visual Concert VSX (VSX 7000).

Description	Used With	Part Number	Length	Other Cables Available
Brown RJ-9, offset tab connectors on both ends 	VSX 7000 VSX 8000	2457-20910-003 (with ferrite bead)	Shipped Length: 30 ft (9 m) Maximum Approved Length: 50 ft (15 m)	2457-20910-050: 50 ft (15 m)
		2457-20910-002 (for use with additional mic pod only, without ferrite bead)	Shipped Length: 10 ft (3 m)	

### Main conference link (with ferrite bead)

Use this cable to connect a microphone pod (or Visual Concert VSX, if using a VSX 7000) to the system.

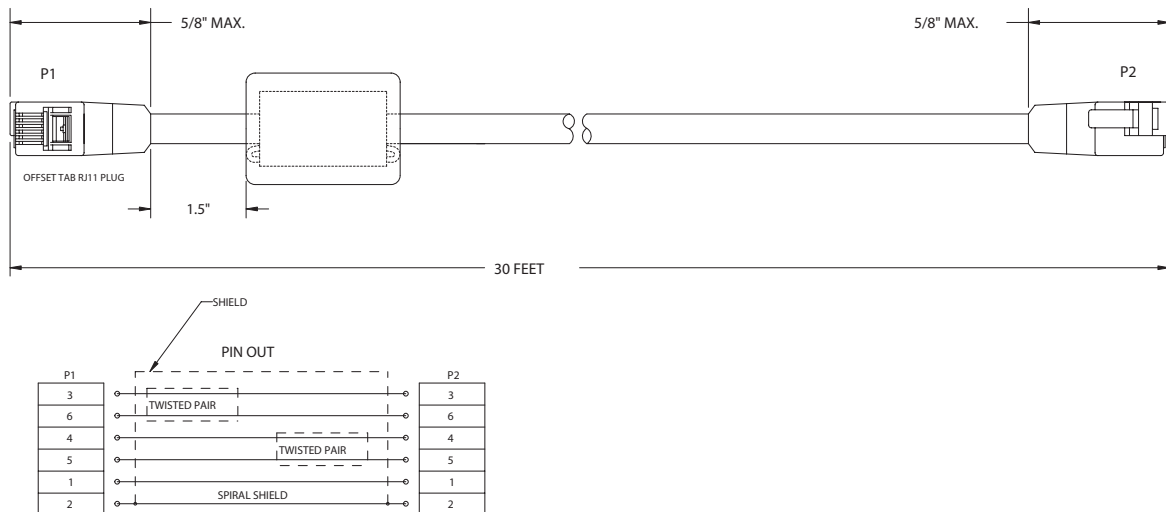

This drawing is provided for design reference only. Polycom claims no responsibility or liability for the quality, performance and/or reliability of cables based on this reference drawing. Cables are available from Polycom that meet the appropriate manufacturing tolerances, quality and performance parameters.

## Secondary conference link (without ferrite bead)

Use this cable to connect an additional microphone pod to a Visual Concert VSX (if using a VSX 7000) or microphone pod that is connected to the system. If you are using a VSX 7000, you can also use this cable to connect a Visual Concert VSX unit to a microphone pod that is connected to the system.

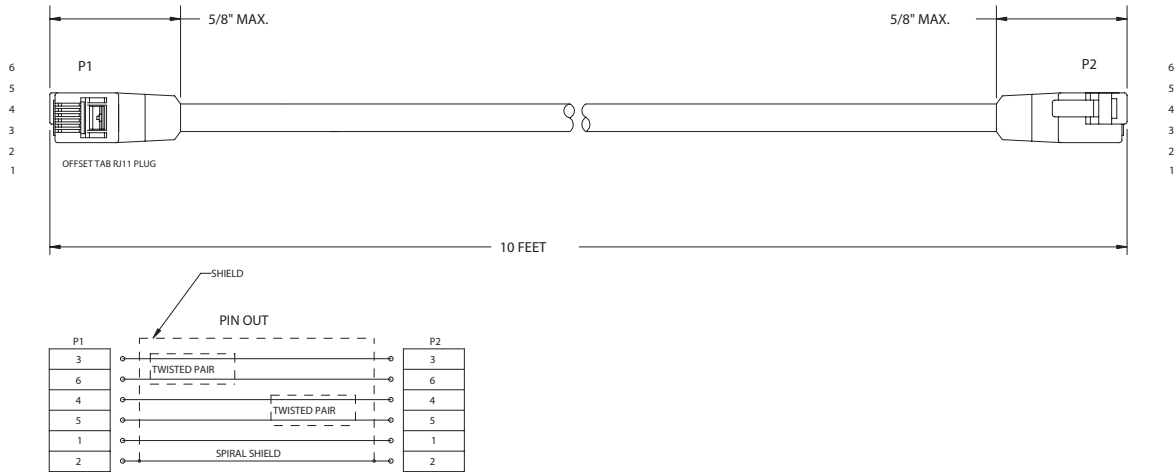

This drawing is provided for design reference only. Polycom claims no responsibility or liability for the quality, performance and/or reliability of cables based on this reference drawing. Cables are available from Polycom that meet the appropriate manufacturing tolerances, quality and performance parameters.

## Audio Cable

This cable connects a VSX system to an external audio system.

Description	Used With	Part Number	Length
Dual RCA connectors (red/white) on both ends 	VSX 7000 VSX 8000	2457-09212-001	Shipped Length: 25 ft (7.6 m) Maximum Approved Length: 100 ft (30 m)

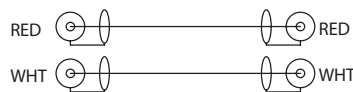
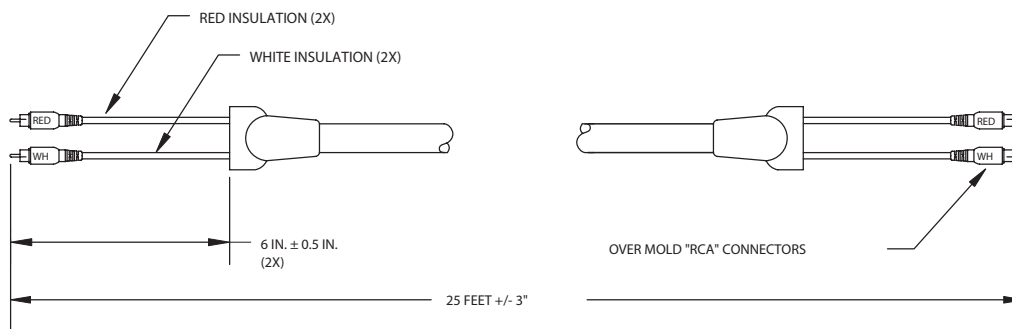

WIRING DIAGRAM



This drawing is provided for design reference only. Polycom claims no responsibility or liability for the quality, performance and/or reliability of cables based on this reference drawing. Cables are available from Polycom that meet the appropriate manufacturing tolerances, quality and performance parameters.

## Vortex Cable

This cable connects a VSX 8000 to a Vortex mixer.

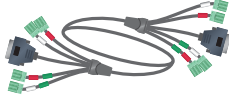
Description	Used With	Part Number	Length
4 mini-Phoenix + DB-9 on both ends 	VSX 8000	2457-21978-001	Shipped Length: 6 ft (1.8 m)

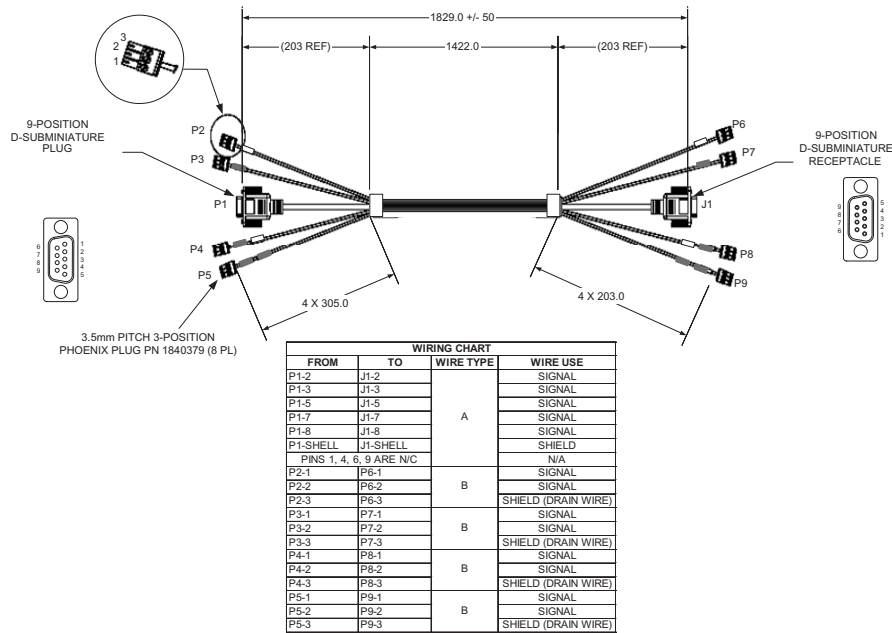

This drawing is provided for design reference only. Polycom claims no responsibility or liability for the quality, performance and/or reliability of cables based on this reference drawing. Cables are available from Polycom that meet the appropriate manufacturing tolerances, quality and performance parameters.

## VSX to VTX Cable

This cable connects a VSX system to a VTX 1000 conference phone.

Description	Used With	Part Number	Length	Other Cables Available
Black offset RJ-9 to RJ-45 	VSX 7000 VSX 8000	2457-21626-001	Shipped Length: 30 ft (9 m)	2457-21626-050 50 ft (15 m)

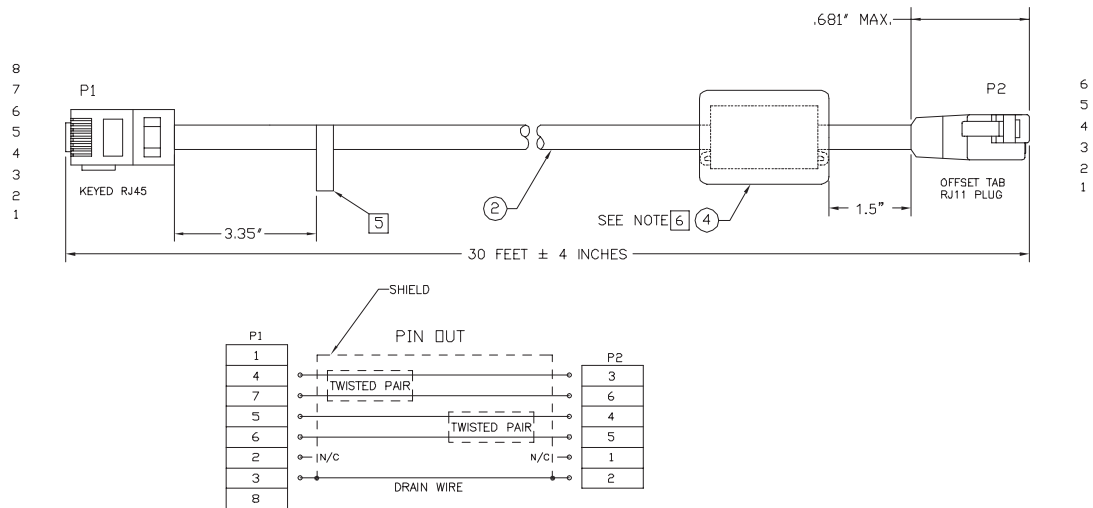

This drawing is provided for design reference only. Polycom claims no responsibility or liability for the quality, performance and/or reliability of cables based on this reference drawing. Cables are available from Polycom that meet the appropriate manufacturing tolerances, quality and performance parameters.

## Visual Concert to VSX Cable

This cable connects a VSX 7000 to a Visual Concert VSX.

Description	Used With	Part Number	Length	Other Cables Available
 Black offset RJ-9 to RJ-45	VSX 7000	2457-21624-001	Shipped Length: 10 ft Maximum Approved Length:	2457-21625-001 3 ft (0.9 m)

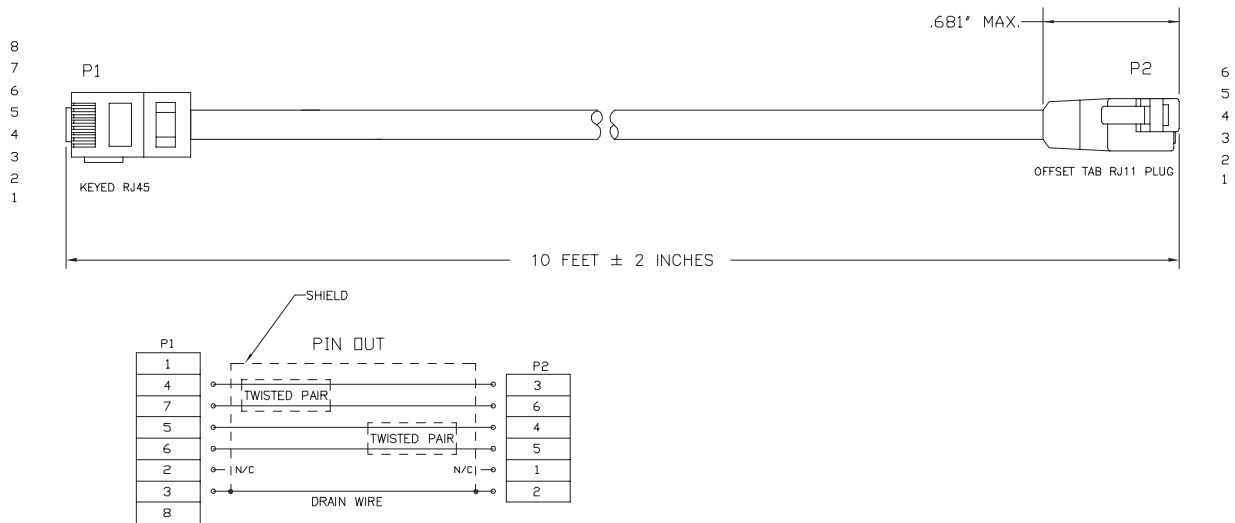

This drawing is provided for design reference only. Polycom claims no responsibility or liability for the quality, performance and/or reliability of cables based on this reference drawing. Cables are available from Polycom that meet the appropriate manufacturing tolerances, quality and performance parameters.

# Serial (RS-232) Cables

## RS-232 Cable (VSX 7000)

This cable connects a VSX 7000 to a serial device.

Description	Used With	Part Number	Length	Other Cables Available
DB-9 to 8-pin mini-DIN 	VSX 7000	2457-09156-001	Shipped Length: 10 ft Maximum Approved Length: 100 ft (30 m)	Use 2457-21714-001 instead when connecting to a modem.
		2457-10029-001 (RTS/CTS not supported on this cable)	Shipped Length: 50 ft (15 m)	

### RS-232 Cable, 10 ft

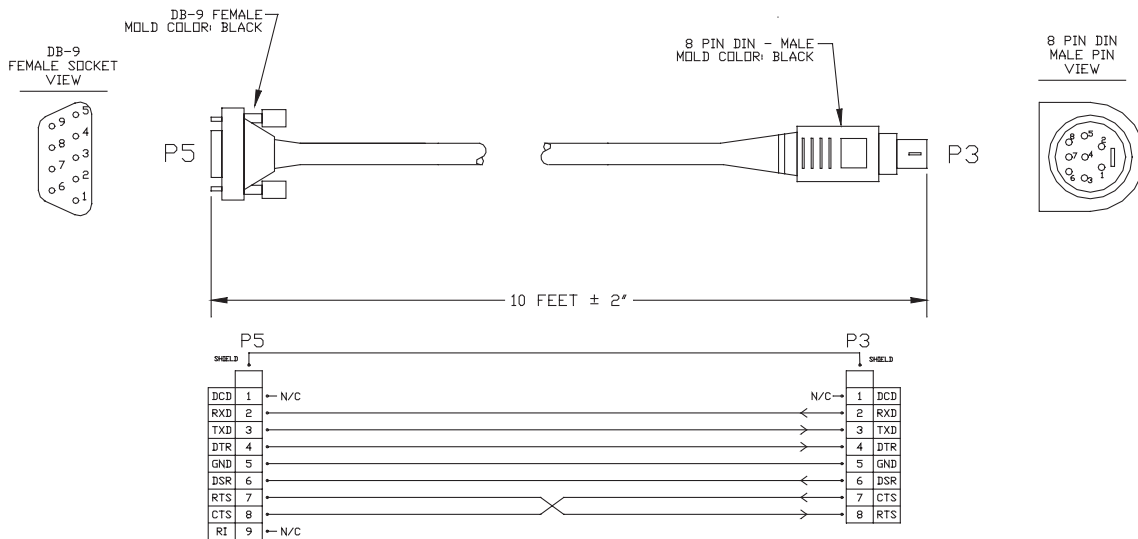

This drawing is provided for design reference only. Polycom claims no responsibility or liability for the quality, performance and/or reliability of cables based on this reference drawing. Cables are available from Polycom that meet the appropriate manufacturing tolerances, quality and performance parameters.

## RS-232 Cable, 50 ft

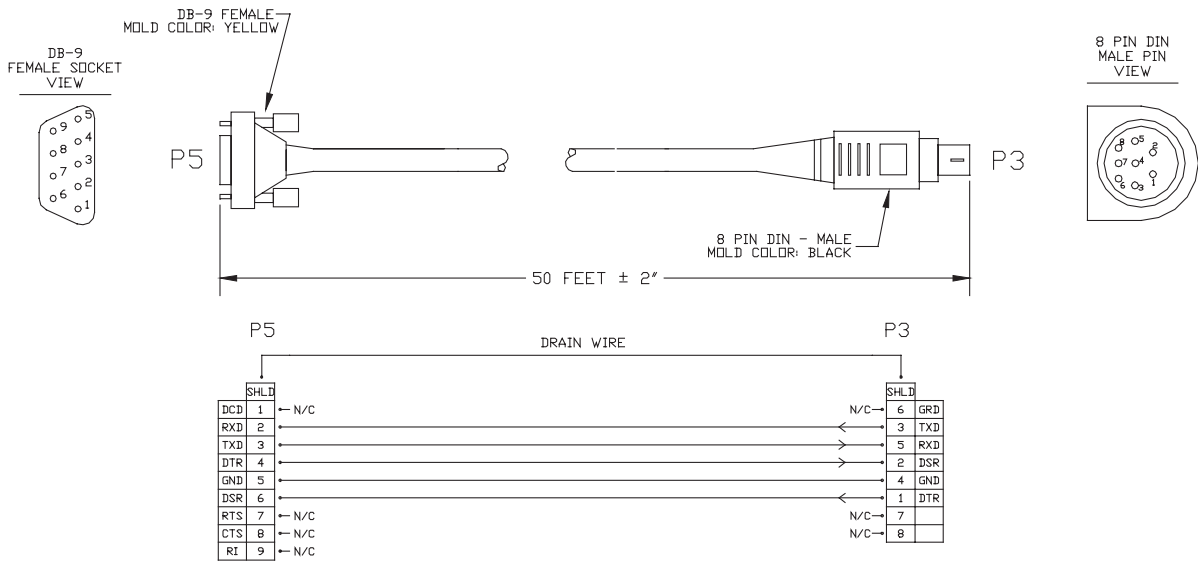

This drawing is provided for design reference only. Polycom claims no responsibility or liability for the quality, performance and/or reliability of cables based on this reference drawing. Cables are available from Polycom that meet the appropriate manufacturing tolerances, quality and performance parameters.



## RS-232 Cable (VSX 8000)

This cable connects a VSX 8000 to a serial device in pin 2.

Description	Used With	Part Number	Length
	VSX 8000 (may require null modem adapter)	2457-09172-001	Shipped Length: 25 ft (7.6 m) Maximum Approved Length: 100 ft (30 m)

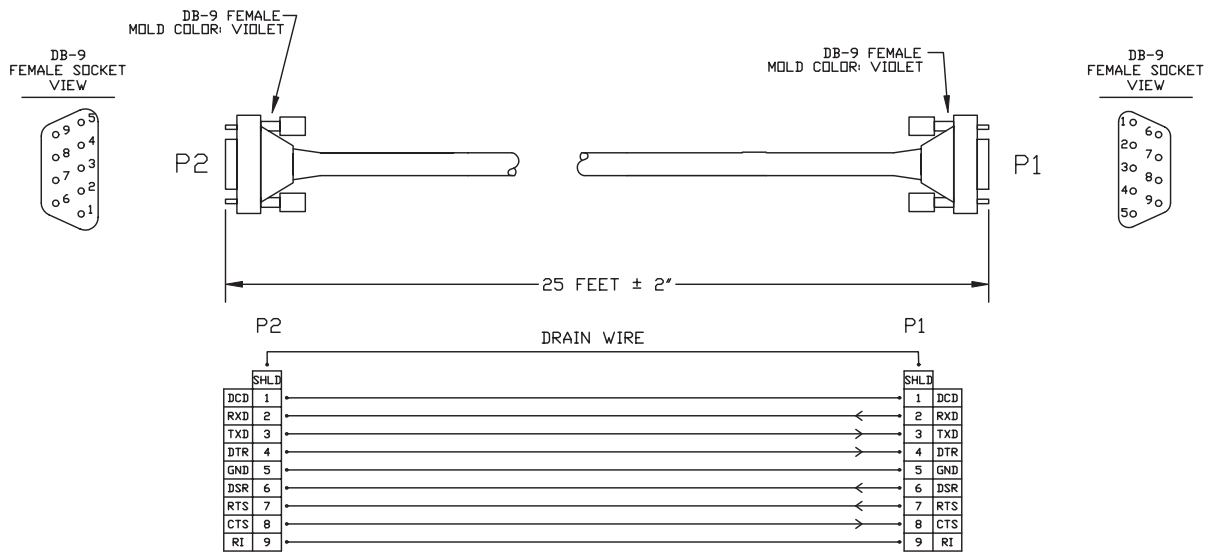

This drawing is provided for design reference only. Polycom claims no responsibility or liability for the quality, performance and/or reliability of cables based on this reference drawing. Cables are available from Polycom that meet the appropriate manufacturing tolerances, quality and performance parameters.

## RS-232 Adapter

This adapter connects a camera control cable to one of the VSX 8000's RS-232 ports.

Description	Used With	Part Number
DB-15 to DB-9	VSX 8000	2457-21930-001

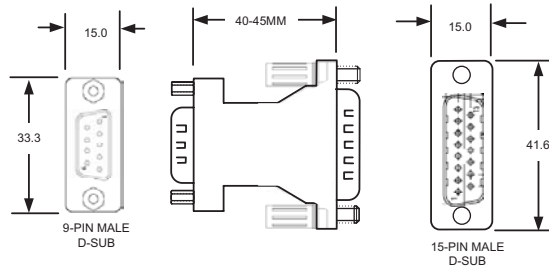

CONNECTION TABLE		
9-PIN	15-PIN	SIGNAL
2	7	RXD/TXD
3	14	TXD/RXD
5	12	GND
ALL OTHERS	N/C	N/A



This drawing is provided for design reference only. Polycom claims no responsibility or liability for the quality, performance and/or reliability of cables based on this reference drawing. Cables are available from Polycom that meet the appropriate manufacturing tolerances, quality and performance parameters.

## Null Modem Cable

This cable connects a VSX 7000 to a serial device.

Description	Used With	Part Number	Length
8-pin mini-DIN to DB-9	VSX 7000	2457-21714-001	Shipped Length: 25 ft (7.6 m)

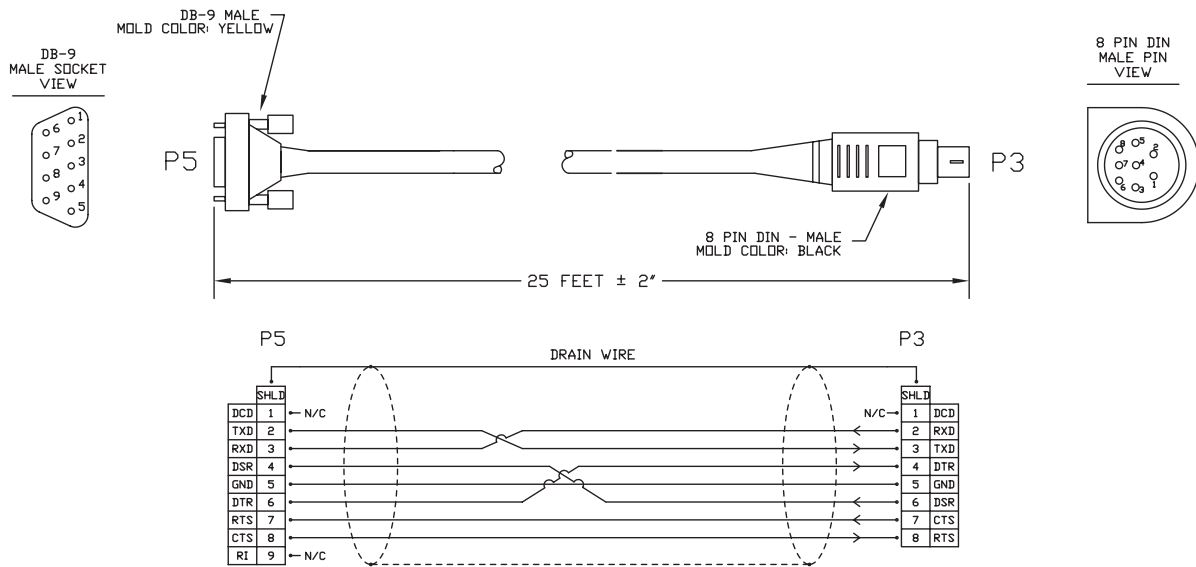

This drawing is provided for design reference only. Polycom claims no responsibility or liability for the quality, performance and/or reliability of cables based on this reference drawing. Cables are available from Polycom that meet the appropriate manufacturing tolerances, quality and performance parameters.

## Null Modem Adapter

This adapter is used when connecting a VSX 8000 to a serial device that transmits on pin 3.

Description	Used With	Part Number
Male to female DB-9 adapter plug 	VSX 8000	1517-21577-001

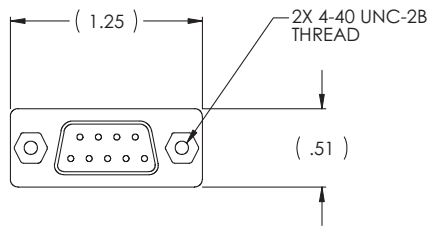
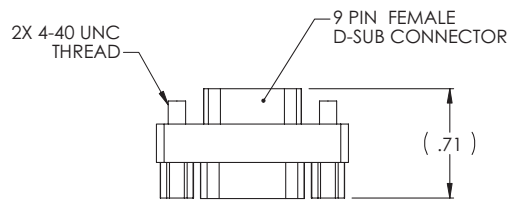

DB9F	DB9M
PIN 1&6	PIN 4
PIN 2	PIN 3
PIN 3	PIN 2
PIN 4	PIN 1&6
PIN 5	PIN 5
PIN 7	PIN 8
PIN 8	PIN 7
PIN 9	N/C

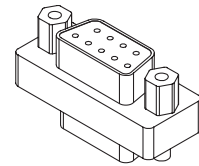
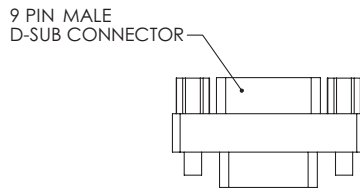

This drawing is provided for design reference only. Polycom claims no responsibility or liability for the quality, performance and/or reliability of cables based on this reference drawing. Cables are available from Polycom that meet the appropriate manufacturing tolerances, quality and performance parameters.

# Content Sharing Cables

## Visual Concert VSX Cable

This cable connects a Visual Concert VSX to a PC.

Description	Used With	Part Number	Length
RJ-45, HD-15, and stereo jack connectors on both ends 	VSX 7000	2457-10757-001	Shipped Length: 6 ft (1.8 m)

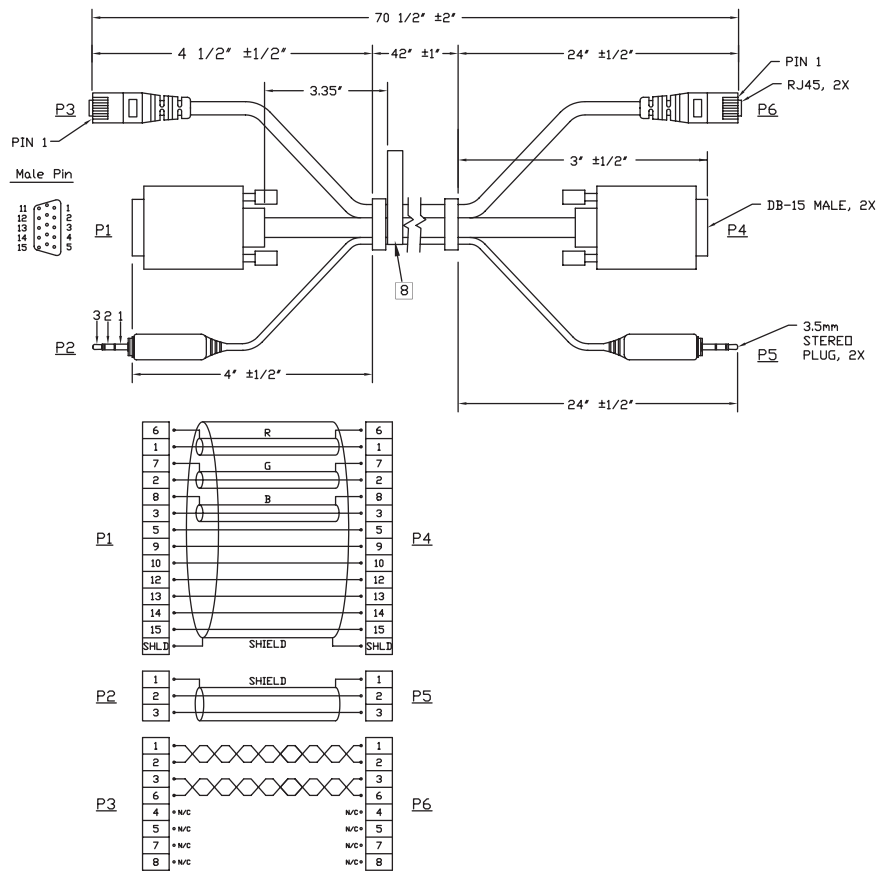

This drawing is provided for design reference only. Polycom claims no responsibility or liability for the quality, performance and/or reliability of cables based on this reference drawing. Cables are available from Polycom that meet the appropriate manufacturing tolerances, quality and performance parameters.

## ImageShare II to PC Cable

This cable connects an ImageShare II to a PC.

Description	Used With	Part Number	Length
HD-15 and stereo jack connectors on both ends 	VSX 8000	185-0020-01	Shipped Length: 3 ft (0.9 m)

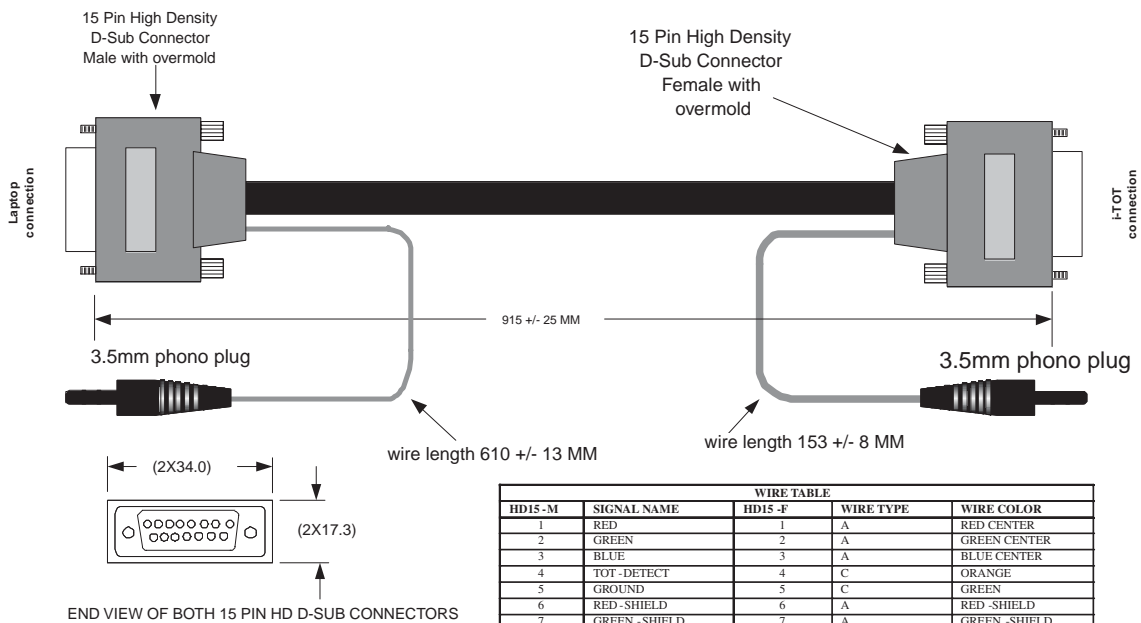

WIRE TABLE				
HD15 -M	SIGNAL NAME	HD15 -F	WIRE TYPE	WIRE COLOR
1	RED	1	A	RED CENTER
2	GREEN	2	A	GREEN CENTER
3	BLUE	3	A	BLUE CENTER
4	TOT -DETECT	4	C	ORANGE
5	GROUND	5	C	GREEN
6	RED -SHIELD	6	A	RED -SHIELD
7	GREEN -SHIELD	7	A	GREEN -SHIELD
8	BLUE -SHIELD	8	A	BLUE -SHIELD
9	N/C	9	N/C	N/C
10	SYNC -RETURN	10	B	BLACK -WHITE
11	N/C	11	N/C	N/C
12	SDA	12	C	BROWN
13	H-SYNC	13	B	BLUE
14	V-SYNC	14	B	RED
15	SCL	15	C	YELLOW
3.5mm PLUG				
TIP	LEFT -AUDIO	TIP	A	BLACK
RING	RIGHT -AUDIO	RING	A	WHITE
SLEEVE	OUTER SHIELD	SLEEVE	A	BLACK SHIELD
SLEEVE	OUTER SHIELD	SLEEVE	A	WHITE SHIELD



This drawing is provided for design reference only. Polycom claims no responsibility or liability for the quality, performance and/or reliability of cables based on this reference drawing. Cables are available from Polycom that meet the appropriate manufacturing tolerances, quality and performance parameters.

# 2

## Using the API

This section describes the API commands for software version 7.0. The VSX Series Application Programming Interface (API) is a set of commands for advanced users who want to automate a VSX system. You can use the API by connecting a computer's RS-232 (serial) port to the VSX system. Or, you can use Telnet port 24 over the LAN to use the API.

### Using the API with an RS-232 Interface

---

If you use an RS-232 interface, you must configure the computer and the VSX system for serial communication.

#### Configuring the RS-232 Interface

If you use the API with a serial connection, make sure that the RS-232 interfaces of the VSX system and your computer are configured appropriately.

To access the RS-232 screen on your system, select **System > Admin Settings > General Settings > Serial Port**.

Configure the **Baud Rate** and **RS-232 Mode** options as follows:

Option	Configure this way on your computer	Configure this way on the VSX system
Baud Rate	Must be the same rate for both devices. Available rates are: <ul style="list-style-type: none"><li>• 9600</li><li>• 14400</li><li>• 19200</li><li>• 38400</li><li>• 57600</li><li>• 115200</li></ul>	
RS-232 Mode	—	Control

The RS-232 port on the VSX system supports two modes: Control and Pass-Thru.

In Control Mode, a device (for example, a PC) connected to the RS-232 port can control the system using the Remote Control API.

In Pass-Thru Mode, the operational modes of both endpoints' RS-232 ports depend on the port configuration of each endpoint.

## Starting an API Session via an RS-232 Interface

After you have verified that the VSX system and your computer are both configured appropriately, set up both devices as follows:

1. Power off the computer and the VSX system.
2. Use an RS-232 cable to connect the computer's RS-232 port to the VSX 7000's RS-232 port or the VSX 8000's RS-232 port 1 or port 2.

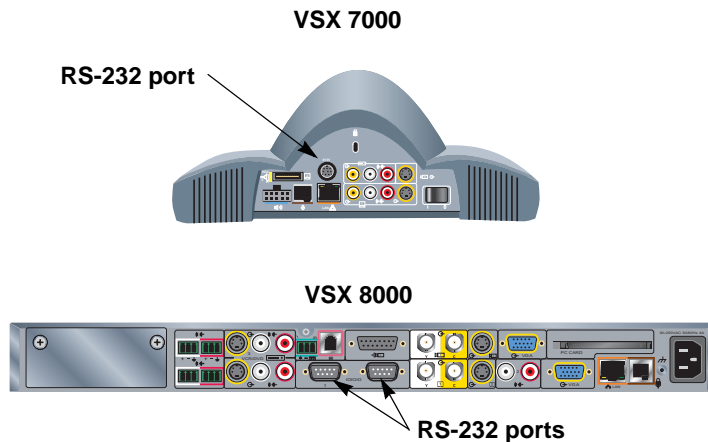

3. Power on the computer and the VSX system.
4. From the computer, start a serial session using HyperTerminal or another appropriate utility.

## Using the API with a LAN Connection

---

If you have a PC connected to the LAN, you can use the API via Telnet port 24.

1. On the PC, open a command line interface.
2. Start a Telnet session using the VSX system's IP address and port 24 — for example, `telnet 255.255.255.255 24`.



# 3

## System Commands

This section describes the system shell commands and their parameters. The commands are categorized into these sections:

- ❑ API Commands
- ❑ Audio Commands
- ❑ Call Commands
- ❑ Camera Control Commands
- ❑ Diagnostics and Statistics Commands
- ❑ IP Commands
- ❑ ISDN Commands
- ❑ Peripherals Commands
- ❑ Polycom Tools Commands
- ❑ Security and Permissions Commands
- ❑ Video Commands

For a list of all the commands in alphabetical order, see the [Alphabetical List of Commands](#) section on [page 3-3](#).

## Syntax Conventions

---

The following conventions are used for the API commands.

All of the commands are case sensitive.

Convention	Meaning
<b>&lt;param&gt;</b> <b>&lt;param1 param2&gt;</b>	Required parameter. Multiple parameters are separated by the pipe (" ") character. Example: <b>allowdialing &lt;yes no get&gt;</b> This shows that the <b>allowdialing</b> command must be followed by one of the arguments listed.
<b>[param]</b> <b>["param"]</b>	Optional parameter. Quotation marks indicate strings to be supplied by the user. Example: <b>adminpassword &lt;set get&gt; ["password"]</b> This shows that the <b>adminpassword</b> command can be used to set a password defined by the user. Use quotation marks when entering strings that contain spaces. To set My VSX Password as the administrator password, you would enter this command: <code>adminpassword set "My VSX Password"</code>
<b>{a..z}</b>	Range of alphanumeric values. Example: <b>abk letter &lt;{a..z}&gt;</b> This shows that the <b>abk</b> command can be used to return address book entries that begin with an alphanumeric character in the range specified.
<b>{n..nn}</b>	Range of numeric values. Example: <b>camera near &lt;{1..4}&gt;</b> This shows that the <b>camera</b> command can be used to select camera 1, 2, 3, or 4 at the near site.
<b>"n"</b>	A number of any value.



---

Although the API command parser accepts the minimum number of characters in a command which makes it unique, you should always use the full command string when writing applications to run the VSX system. The shortcuts are merely to save time when testing or developing an application.

---

# Alphabetical List of Commands

The following table lists the commands in alphabetical order.

Command	Category
<b>!</b> command on page 3-11	API
<b>abk</b> command on page 3-20	Call
<b>adminpassword</b> command on page 3-107	Security and Permissions
<b>advnetstats</b> command on page 3-42	Diagnostics and Statistics
<b>alertusertone</b> command on page 3-20	Call
<b>alertvideotone</b> command on page 3-21	Call
<b>all register</b> command on page 3-88	Polycom Tools
<b>all unregister</b> command on page 3-88	Polycom Tools
<b>allowabkchanges</b> command on page 3-107	Security and Permissions
<b>allowcamerapresetssetup</b> command on page 3-107	Security and Permissions
<b>allowdialing</b> command on page 3-108	Security and Permissions
<b>allowmixedcalls</b> command on page 3-21	Call
<b>allowstreaming</b> command on page 3-21	Call
<b>allowusersetup</b> command on page 3-108	Security and Permissions
<b>answer</b> command on page 3-21	Call
<b>areacode</b> command on page 3-69	ISDN
<b>audiometer</b> command on page 3-44	Diagnostics
<b>audiotransmitlevel</b> command on page 3-16	Audio
<b>autoanswer</b> command on page 3-22	Call
<b>backlightcompensation</b> command on page 3-110	Video
<b>bri1enable, bri2enable, bri3enable, bri4enable</b> command on page 3-69	ISDN
<b>briallenable</b> command on page 3-69	ISDN
<b>button</b> command on page 3-89	Polycom Tools
<b>calldetail</b> command on page 3-44	Diagnostics
<b>calldetailreport</b> command on page 3-22	Call
<b>callencryption</b> command on page 3-108	Security and Permissions, Call
<b>callpreference</b> command on page 3-22	Call
<b>callstate</b> command on page 3-45	Diagnostics and Statistics, Call

Command	Category
<b>camera</b> command on page 3-39	Camera Control
<b>cameradirection</b> command on page 3-40	Camera Control
<b>chaircontrol</b> command on page 3-24	Call
<b>colorbar</b> command on page 3-45	Diagnostics and Statistics
<b>colorscheme</b> command on page 3-46	Diagnostics
<b>configchange</b> command on page 3-90	Polycom Tools
<b>confirmdiradd</b> command on page 3-108	Security and Permissions
<b>confirmdirdel</b> command on page 3-109	Security and Permissions
<b>country</b> command on page 3-90	Polycom Tools
<b>cts</b> command on page 3-69	ISDN
<b>daylightsavings</b> command on page 3-90	Polycom Tools
<b>dcd</b> command on page 3-69	ISDN
<b>dcdfilter</b> command on page 3-70	ISDN
<b>defaultgateway</b> command on page 3-58	IP
<b>dhcp</b> command on page 3-58	IP
<b>dial</b> command on page 3-25	Call
<b>dialchannels</b> command on page 3-25	Call
<b>dialingdisplay</b> command on page 3-91	Polycom Tools
<b>diffservaudio, diffservfec, diffserv-video</b> command on page 3-26	Call
<b>dir</b> command on page 3-12	API
<b>directory</b> command on page 3-26	Call
<b>display</b> command on page 3-46	Diagnostics and Statistics
<b>displayglobaladdresses</b> command on page 3-109	Security and Permissions
<b>displaygraphics</b> command on page 3-110	Video
<b>displayipext</b> command on page 3-91	Polycom Tools
<b>displayipisdninfo</b> command on page 3-47	Diagnostics and Statistics
<b>displayparams</b> command on page 3-92	Tools
<b>dns</b> command on page 3-58	IP
<b>dsr</b> command on page 3-70	ISDN
<b>dsranswer</b> command on page 3-70	ISDN
<b>dtr</b> command on page 3-70	ISDN
<b>dualmonitor</b> command on page 3-110	Video
<b>dynamicbandwidth</b> command on page 3-59	IP

Command	Category
<b>e164ext</b> command on page 3-59	IP
<b>echocanceller</b> command on page 3-16	Audio
<b>echocancellerred</b> command on page 3-16	Audio
<b>echocancellerwhite</b> command on page 3-17	Audio
<b>enablesnmp</b> command on page 3-93	Polycom Tools
<b>encryption</b> command on page 3-109	Security and Permissions
<b>exit</b> command on page 3-12	API
<b>farcontrolnearcamera</b> command on page 3-41	Camera Control
<b>farnametimedisplay</b> command on page 3-26	Call
<b>gabk</b> command on page 3-26	Call
<b>gabpassword</b> command on page 3-93	Polycom Tools
<b>gabserverip</b> command on page 3-94	Polycom Tools
<b>gatekeeperip</b> command on page 3-59	IP
<b>gatewayareacode</b> command on page 3-60	IP
<b>gatewaycountrycode</b> command on page 3-60	IP
<b>gatewayext</b> command on page 3-60	IP
<b>gatewaynumber</b> command on page 3-60	IP
<b>gatewaynumbertype</b> command on page 3-61	IP
<b>gatewayprefix</b> command on page 3-61	IP
<b>gatewaysetup</b> command on page 3-62	IP
<b>gatewaysuffix</b> command on page 3-62	IP
<b>gential</b> command on page 3-27	Call
<b>gentialtonepots</b> command on page 3-27	Call
<b>generatetone</b> command on page 3-47	Diagnostics and Statistics
<b>get screen</b> command on page 3-94	Polycom Tools
<b>getcallstate</b> command on page 3-47	Diagnostics and Statistics
<b>gmscity</b> command on page 3-94	Polycom Tools
<b>gmscontactemail</b> command on page 3-94	Polycom Tools
<b>gmscontactfax</b> command on page 3-94	Polycom Tools
<b>gmscontactnumber</b> command on page 3-95	Polycom Tools

Command	Category
<b>gmscontactperson</b> command on page 3-95	Polycom Tools
<b>gmscountry</b> command on page 3-95	Polycom Tools
<b>gmsstate</b> command on page 3-96	Polycom Tools
<b>gmstechsupport</b> command on page 3-96	Polycom Tools
<b>gmsurl</b> command on page 3-96	Polycom Tools
<b>graphicsmonitor</b> command on page 3-84	Peripherals, Video
<b>h323name</b> command on page 3-63	IP
<b>hangup</b> command on page 3-27	Call
<b>help</b> command on page 3-13	API
<b>history</b> command on page 3-13	API
<b>homecallquality</b> command on page 3-96	Polycom Tools
<b>homemultipoint</b> command on page 3-97	Polycom Tools
<b>homerecentcalls</b> command on page 3-97	Polycom Tools
<b>homesystem</b> command on page 3-97	Polycom Tools
<b>homesystemname</b> command on page 3-97	Polycom Tools
<b>hostname</b> command on page 3-63	IP
<b>ipaddress</b> command on page 3-64	IP
<b>ipdialspeed</b> command on page 3-28	Call
<b>ipisdninfo</b> command on page 3-28	Call
<b>ipprecaudio, ipprecfecc, ipprecvideo</b> command on page 3-64	IP
<b>ipstat</b> command on page 3-64	IP
<b>isdnareacode</b> command on page 3-28	Call
<b>isdncountrycode</b> command on page 3-70	ISDN
<b>isdndialingprefix</b> command on page 3-71	ISDN
<b>isdndialspeed</b> command on page 3-29	Call
<b>isdnum</b> command on page 3-71	ISDN
<b>isdnswitch</b> command on page 3-71	ISDN
<b>keypadaudioconf</b> command on page 3-17	Audio
<b>language</b> command on page 3-98	Polycom Tools
<b>lanport</b> command on page 3-65	IP
<b>lanstat</b> command on page 3-48	Diagnostics and Statistics
<b>linestate</b> command on page 3-29	Call
<b>listen</b> command on page 3-98	Polycom Tools

Command	Category
<b>localdatetime</b> command on page 3-98	Polycom Tools
<b>marqueedisplaytext</b> command on page 3-99	Polycom Tools
<b>maxgabinternationalcallspeed</b> command on page 3-29	Call
<b>maxgabinternetcallspeed</b> command on page 3-30	Call
<b>maxgabisdncallspeed</b> command on page 3-30	Dial/Call
<b>maxtimeincall</b> command on page 3-30	Call
<b>meetingpassword</b> command on page 3-30	Call
<b>midrangespeaker</b> command on page 3-17	Polycom Tools
<b>monitor1</b> command on page 3-84	Peripherals, Video
<b>monitor2</b> command on page 3-84	Peripherals, Video
<b>mpautoanswer</b> command on page 3-31	Call
<b>mpmode</b> command on page 3-32	Call
<b>mute</b> command on page 3-18	Audio
<b>muteautoanswer</b> command on page 3-18	Audio
<b>natconfig</b> command on page 3-109	Security and Permissions
<b>nearloop</b> command on page 3-49	Diagnostics and Statistics
<b>netstats</b> command on page 3-50	Diagnostics and Statistics
<b>ntpmode</b> command on page 3-99	Polycom Tools
<b>ntpserver</b> command on page 3-99	Polycom Tools
<b>numberofmonitors</b> command on page 3-111	Video
<b>numdigitsdid</b> command on page 3-65	Call, IP
<b>numdigitstext</b> command on page 3-66	Call, IP
<b>outboundcallroute</b> command on page 3-33	Call
<b>pause</b> command on page 3-13	API
<b>phone</b> command on page 3-33	Call
<b>ping</b> command on page 3-50	Diagnostics and Statistics
<b>pip</b> command on page 3-112	Call, Video
<b>popupinfo</b> command on page 3-100	Polycom Tools
<b>preset</b> command on page 3-41	Camera Control
<b>priareacode</b> command on page 3-72	ISDN

Command	Category
<b>pricallbycall</b> command on page 3-72	ISDN
<b>prichannel</b> command on page 3-73	ISDN
<b>pricsu</b> command on page 3-74	ISDN
<b>pridialchannels</b> command on page 3-74	ISDN
<b>priintlprefix</b> command on page 3-74	ISDN
<b>prilinebuildout</b> command on page 3-75	ISDN
<b>prilinesignal</b> command on page 3-76	ISDN
<b>primarycamera</b> command on page 3-41	Camera Control
<b>prinumber</b> command on page 3-76	ISDN
<b>prinumberingplan</b> command on page 3-77	ISDN
<b>prioutsideline</b> command on page 3-77	ISDN
<b>priswitch</b> command on page 3-78	ISDN
<b>reboot</b> command on page 3-51	API
<b>recentcalls</b> command on page 3-34	Call
<b>registerthissystem</b> command on page 3-13	Polycom Tools
<b>repeat</b> command on page 3-14	API
<b>requireacctnumtodial</b> command on page 3-35	Call
<b>roomphonenumber</b> command on page 3-35	Call
<b>rs232 baud</b> command on page 3-100	Polycom Tools
<b>rs232 mode</b> command on page 3-101	Polycom Tools
<b>rs366dialing</b> command on page 3-35	Call
<b>rt</b> command on page 3-78	ISDN
<b>rts</b> command on page 3-78	ISDN
<b>run</b> command on page 3-101	Polycom Tools
<b>screen</b> command on page 3-101	Polycom Tools
<b>serialnum</b> command on page 3-51	Diagnostics and Statistics
<b>setaccountnumber</b> command on page 3-36	Call
<b>showpopup</b> command on page 3-101	Polycom Tools
<b>sleep</b> command on page 3-84	Peripherals
<b>sleeptext</b> command on page 3-85	Peripherals
<b>sleeptime</b> command on page 3-85	Peripherals



Command	Category
<b>snapshottimeout</b> command on page 3-102	Polycom Tools
<b>snmpadmin</b> command on page 3-102	Polycom Tools
<b>snmpcommunity</b> command on page 3-102	Polycom Tools
<b>snmpconsoleip</b> command on page 3-103	Polycom Tools
<b>snmplocation</b> command on page 3-103	Polycom Tools
<b>snmpsystemdescription</b> command on page 3-103	Polycom Tools
<b>soundeffectsvolume</b> command on page 3-18	Audio
<b>spidnum</b> command on page 3-79	ISDN
<b>st</b> command on page 3-79	ISDN
<b>stream</b> command on page 3-85	Peripherals
<b>streamannounce</b> command on page 3-85	Peripherals
<b>streamaudioport</b> command on page 3-85	Peripherals
<b>streamenable</b> command on page 3-86	Peripherals
<b>streammulticastip</b> command on page 3-86	Peripherals
<b>streamrestoredefaults</b> command on page 3-86	Peripherals
<b>streamrouterhops</b> command on page 3-86	Peripherals
<b>streamspeek</b> command on page 3-87	Peripherals
<b>streamvideoport</b> command on page 3-87	Peripherals
<b>subnetmask</b> command on page 3-66	IP
<b>subwoofer</b> command on page 3-19	Polycom Tools
<b>subwooferoffset</b> command on page 3-103	Polycom Tools
<b>sysinfo</b> command on page 3-51	Polycom Tools
<b>systemname</b> command on page 3-36	Call
<b>tcpports</b> command on page 3-66	IP
<b>techsupport</b> command on page 3-51	Diagnostics and Statistics
<b>teleareacode</b> command on page 3-36	Call
<b>telecountrycode</b> command on page 3-37	Call
<b>telenumber</b> command on page 3-37	Call
<b>testlan</b> command on page 3-52	Diagnostics and Statistics
<b>textinput</b> command on page 3-104	Polycom Tools

Command	Category
<b>timediffgmt</b> command on page 3-104	Polycom Tools
<b>traceroute</b> command on page 3-104	Polycom Tools
<b>typeofservice</b> command on page 3-67	IP
<b>udpports</b> command on page 3-67	IP
<b>usefixedports</b> command on page 3-67	IP
<b>usegatekeeper</b> command on page 3-67	IP
<b>usepathnavigator</b> command on page 3-105	Polycom Tools
<b>v35dialingprotocol</b> command on page 3-79	ISDN
<b>v35num</b> command on page 3-80	ISDN
<b>v35portsused</b> command on page 3-80	ISDN
<b>v35prefix</b> command on page 3-81	ISDN
<b>v35profile</b> command on page 3-82	ISDN
<b>v35suffix</b> command on page 3-83	ISDN
<b>validateacctnum</b> command on page 3-37	Call
<b>vcbutton</b> command on page 3-38	Call
<b>vcrecordsource</b> command on page 3-87	Peripherals
<b>vcstream</b> command on page 3-87	Peripherals
<b>version</b> command on page 3-14	API
<b>volume</b> command on page 3-19	Audio, Call
<b>vtxstate</b> command on page 3-87	Peripherals
<b>waitfor</b> command on page 3-14	API
<b>wake</b> command on page 3-105	Polycom Tools
<b>wanipaddress</b> command on page 3-68	IP
<b>webport</b> command on page 3-105	Polycom Tools
<b>whoami</b> command on page 3-15	API
<b>winsresolution</b> command on page 3-68	IP
<b>winsserver</b> command on page 3-106	Polycom Tools
<b>xmladvnetstats</b> command on page 3-55	Diagnostics
<b>xmlnetstats</b> command on page 3-56	Diagnostics

## API Commands

Command	Syntax	Description	Example
!	<p>!<b>&lt;“string”</b>{1..64}&gt;</p> <p>Where:</p> <ul style="list-style-type: none"> <li>• <b>“string”</b>: Specifies the most recent command from the history list that begins with this string.</li> <li>• <b>{1..64}</b>: Specifies the nth command in the history list.</li> </ul>	<p>Allows you to execute a previously used command starting with a specific number or letter from the history list. For more information about the history list, refer to the <a href="#">history</a> command on page 3-13.</p>	<pre>-&gt;gatewaynumber set 123456789 gatewaynumber 123456789 restart system for changes to take effect. restart now? &lt;y,n&gt; -&gt;hangup video hanging up video call -&gt;history 1 gatewaynumber set 123456789 2 hangup video 3 history</pre> <p>Consequently, each of the following ! &lt;letter or number&gt; commands executes the command and print its output from the history list.</p> <pre>-&gt;!1 gatewaynumber set 123456789 gatewaynumber 123456789 restart system for changes to take effect. restart now? &lt;y,n&gt; -&gt;!2 hangup video hanging up video call -&gt;!h hangup video hanging up video call</pre>

Command	Syntax	Description	Example
!(continued)			<pre>-&gt;!hi history 1 gatewaynumber set 123456789 2 hangup video 3 history 4 gatewaynumber set 123456789 5 hangup video 6 hangup video 7 history -&gt;!gat gatewaynumber set 123456789 gatewaynumber 123456789 restart system for changes to take effect. restart now? &lt;y,n&gt; -&gt;history 1 gatewaynumber set 123456789 2 hangup video 3 history 4 gatewaynumber set 123456789 5 hangup video 6 hangup video 7 history 8 gatewaynumber set 123456789 9 history</pre>
dir	<b>dir ["string"]</b> Where: <ul style="list-style-type: none"> <li>• <b>"string"</b>: Lists flash files which partially match a string of up to 250 alphanumeric characters. To list all the files, omit "string".</li> </ul>	Lists flash files. No wild cards are allowed.	<pre>dir dat dir abk dir</pre>
exit	<b>exit</b>	Ends the API command session.	<pre>exit</pre>

Command	Syntax	Description	Example
help	<p><b>help</b>  <b>[all help verbose terse]"string"]</b>  <b>syntax]</b></p> <p>Where:</p> <ul style="list-style-type: none"> <li>• <b>all</b>: Returns detailed help for all commands.</li> <li>• <b>help</b>: Describes the various types of help described in this section.</li> <li>• <b>verbose</b>: Sets verbose mode, which shows syntax and help for commands.</li> <li>• <b>terse</b>: Sets terse mode, which shows help for commands without showing syntax.</li> <li>• <b>"string"</b>: Returns detailed help for any commands containing "string". Use quotation marks around strings that contain spaces. For example: "display call".</li> <li>• <b>syntax</b>: Returns the help syntax conventions.</li> </ul>	<p>Returns a simple or detailed list of commands when used with the parameters all, help, string, or syntax. Also switches help display mode when used with the parameters verbose or terse. This command without parameters returns the list of command names only.</p>	<pre>help returns a list of all com- mands, some of which are: ! abk adminpassword advnetstats allowabkchanges alldialing allowusersetup answer areacode1</pre>
history	<p><b>history</b></p>	<p>Lists the last commands used in the current session.</p> <p>If more than 64 commands have been issued, only the last 64 are displayed.</p>	<pre>history might return something like this: 1ipaddress set 192.168.1.105 2hostname set MyVSX 3 lanport 100fdx 4 callstate register 5 lanport get 6history</pre>
pause	<p><b>pause &lt;{0..65535}&gt;</b></p> <p>Where:</p> <ul style="list-style-type: none"> <li>• <b>{0..65535}</b>: Number of seconds to pause.</li> </ul>	<p>Causes the command interpreter to pause before executing the next command. Pauses are useful when commands are retrieved from a script file.</p>	<pre>pause 3 pauses 3 seconds before the next command.</pre>
registerthis-system	<p><b>registerthissystem &lt;yes no get&gt;</b></p> <p>Where:</p> <ul style="list-style-type: none"> <li>• <b>yes</b>: Enables this option (register this system).</li> <li>• <b>no</b>: Disables this option.</li> <li>• <b>get</b>: Returns the current setting (yes or no).</li> </ul>	<p>Sets or gets the system's IP address to be registered and displayed in the Global Directory (GDS) when the system is powered on. If you do not enable this option, the system has access to the GDS, but the IP address does not appear in the Global Directory.</p>	<pre>registerthissys- tem yes</pre>

Command	Syntax	Description	Example
repeat	<p><b>repeat &lt;{1..n}&gt;</b></p> <p>Where:</p> <ul style="list-style-type: none"> <li>• <b>&lt;{1..n}&gt;</b>: Repeats the specified command in the history list.</li> </ul> <p>Values larger than the number of commands in the history list are not valid. The history list may contain up to 64 commands.</p>	Allows you to repeat a specified command from the history list. For more information about the history list, refer to the <a href="#">history</a> command on page 3-13.	<p>The following is a sample history list containing the command entries:</p> <pre>1 dynamic-bandwidth get 2 get screen 3 language get 4 primary-callchoice ip 5 lanstat min 1</pre> <p>Consequently, the command:</p> <pre>repeat 4</pre> <p>will repeat command 4:</p> <pre>primary-callchoice ip</pre> <p>from the history list.</p>
waitfor	<p><b>waitfor &lt;callcomplete systemready&gt;</b></p> <p>Where:</p> <ul style="list-style-type: none"> <li>• <b>callcomplete</b>: Causes the API shell to wait until a call being placed either connects or fails.</li> <li>• <b>systemready</b>: Causes the system to return the message "system is ready" when the system is ready to make a call.</li> </ul>	Used within script files or control panel programs to wait for a specific event before executing the next statement. (See the <a href="#">run</a> command on page 3-101). This command causes the API shell to wait until a call being placed either connects or fails, or until system is ready to place a call (such as after a reboot waiting for the ISDN lines to come up). This command can be used to synchronize a remote controller with the system. The API shell echoes the message "call complete" when the call connects or is aborted.	<pre>waitfor callcomplete</pre>
version	<b>version</b>	Returns the current VSX system's version information. User interface screen location: <b>System &gt; System Information: System Software</b>	<pre>version returns information similar to this: version "Release 7.0 12sep2004 06:09"</pre>

Command	Syntax	Description	Example
whoami	whoami	Displays the same initial banner information as when the RS-232/Telnet session was started with the VSX system.	<pre> whoami might return something like this: Hi, my name is : mine Here is what I know about myself: Model: VSX 7000 Serial Number: 82024102408DAK Software Version: Release 7.0 - 19Jul2004 16:16 Build Information: cknoll on ausgto03.austin.p olycom.com FPGA Revision: 4.3.0 Main Processor: BSP15 v0.0 ~ Core/Mem Clks 405/135 [3:4 0:3] Time In Last Call: 0:00:00 Total Time In Calls: 58:17:10 Total Calls: 81 SNTP Time Service: auto insync ntp1.polycom.com Local Time is: Tue, 20 Jul 2004 17:16:41 -0500 Network Interface: ISDN_QUAD_BRI IP Video Number: 216.54.150.47 ISDN Video Number: 1. MP Enabled: g H323 Enabled: True FTP Enabled: True HTTP Enabled: True SNMP Enabled: True NIC Slot 1 SW Ver: 6.03 NIC Slot 1 Boot Ver: 0.02 </pre>

## Audio Commands

Command	Syntax	Description	Example
audiotransmitlevel	<p><b>audiotransmitlevel</b>  <b>&lt;up down set get register unregister&gt; [-20..30]</b></p> <p>Where:</p> <ul style="list-style-type: none"> <li>• <b>up</b>: Sets the volume 1 decibel higher than the current setting.</li> <li>• <b>down</b>: Sets the volume 1 decibel lower than the current setting.</li> <li>• <b>set</b>: Sets the volume to the specified dB level. Valid values are: {-20..30}</li> <li>• <b>get</b>: Returns the current audio volume of the far site.</li> <li>• <b>register</b>: Registers to receive notification when audio transmit level changes.</li> <li>• <b>unregister</b>: Unregisters to receive notification when audio transmit level changes.</li> </ul>	<p>Sets or gets the audio volume transmitted to the far site. Used when a control system needs to increase the audio gain level of DTMF tones being sent to a gateway.</p>	<pre>audiotransmitlevel up</pre>
echocanceller	<p><b>echocanceller &lt;red white&gt;</b>  <b>&lt;yes no get&gt;</b></p> <p>Where:</p> <ul style="list-style-type: none"> <li>• <b>red</b>: Line in red.</li> <li>• <b>white</b>: Line in white.</li> <li>• <b>yes</b>: Enables the echo canceller option.</li> <li>• <b>no</b>: Disables the echo canceller option.</li> <li>• <b>get</b>: Returns the current setting (yes or no).</li> </ul>	<p>Prevents users from hearing their voice loop back from the far site. This option is enabled by default.</p> <p><b>Note:</b> Polycom strongly recommends that you do <i>not</i> turn off echo cancellation except when using an external microphone system with its own built-in echo cancellation.</p> <p>User interface screen location:  <b>System &gt; Admin Settings &gt; Audio</b> (page 2): <b>Echo Canceller</b></p>	<pre>echocanceller yes</pre>
echocancellerred	<p><b>echocancellerred &lt;yes no get&gt;</b></p> <p>Where:</p> <ul style="list-style-type: none"> <li>• <b>yes</b>: Enables the echo canceller option for red line in.</li> <li>• <b>no</b>: Disables the echo canceller option for red line in.</li> <li>• <b>get</b>: Returns the current setting (yes or no).</li> </ul>	<p>Sets or gets the line in red (right) echo canceller.</p> <p>User interface screen location:  <b>System &gt; Admin Settings &gt; Audio</b> (page 2): <b>Echo Canceller</b></p>	<pre>echocancellerred yes</pre>



Command	Syntax	Description	Example
echocancel- lerwhite	<b>echocancellerwhite &lt;yes no get&gt;</b> Where: <ul style="list-style-type: none"> <li><b>yes:</b> Enables the echo canceller option for white line in.</li> <li><b>no:</b> Disables the echo canceller option for white line in.</li> <li><b>get:</b> Returns the current setting (yes or no).</li> </ul>	Sets or gets the line in white (left) echo canceller. User interface screen location: <b>System &gt; Admin Settings &gt; Audio (page 2): Echo Cancellor</b>	echocancellerwhite yes
keypadaudio- oconf	<b>keypadaudioconf &lt;yes no get&gt;</b> Where: <ul style="list-style-type: none"> <li><b>yes:</b> Enables audio confirmation.</li> <li><b>no:</b> Disables audio confirmation.</li> <li><b>get:</b> Returns the current setting (yes or no).</li> </ul>	Sets the keypad audio confirmation. When this option is enabled, an audio response (English-language only) is echoed when a numeric key is pressed on the remote control. User interface screen location: <b>System &gt; Admin Settings &gt; General Settings &gt; System Settings &gt; Remote Control: Keypad Audio Confirmation</b>	keypadaudioconf yes
midranges- peaker	<b>midrangespeaker &lt;on off get&gt;</b> Where: <ul style="list-style-type: none"> <li><b>on:</b> Turns the midrange speaker on.</li> <li><b>off:</b> Turns the midrange speaker off.</li> <li><b>get:</b> Returns the current setting (on or off).</li> </ul>	Specifies whether to use the system's built-in midrange speaker. (VSX 7000 only) User interface screen location: <b>System &gt; Admin Settings &gt; Audio (page 3): Midrange Speaker</b> <b>Note:</b> This option is only available when stereo audio is disabled.	midrangespeaker on

Command	Syntax	Description	Example
mute	<p><b>mute &lt;register unregister near far&gt;</b>  <b>mute near &lt;on off toggle get&gt;</b>  <b>mute far get</b></p> <p>Where:</p> <ul style="list-style-type: none"> <li>• <b>register:</b> Registers the system to give notification when the mute mode changes.</li> <li>• <b>unregister:</b> Disables register mode.</li> <li>• <b>near:</b> Sets the command for the near site. Requires one of these parameters: on, off, toggle, or get.</li> <li>• <b>far:</b> Sets the command for the far site. Requires the parameter get.</li> </ul> <p>For <b>mute &lt;near far&gt;</b> parameter:</p> <ul style="list-style-type: none"> <li>• <b>on:</b> Turns on the mute mode for the near site (mute near).</li> <li>• <b>off:</b> Turns off the mute mode for the near site (mute near).</li> <li>• <b>toggle:</b> If in mute near mode, switches to the other mode setting (mute near off) and vice versa.</li> <li>• <b>get:</b> Returns the current setting for the near or far site (mute near far get).</li> </ul>	<p>Sets the near or far site mute mode. Also sets the system to register or unregister mode. In register mode, the system sends notification to the RS-232 session when the far or near site is muted or unmuted.</p>	<pre>mute near on</pre>
muteautoanswer	<p><b>muteautoanswer &lt;yes no get&gt;</b></p> <p>Where:</p> <ul style="list-style-type: none"> <li>• <b>yes:</b> Enables Mute Auto Answer Calls mode. The microphone will be muted when the VSX system receives a call while in Auto Answer mode.</li> <li>• <b>no:</b> Disables Mute Auto Answer Calls mode. The microphone will not be muted when the VSX system receives a call while in Auto Answer mode.</li> <li>• <b>get:</b> Returns the current setting (yes or no).</li> </ul>	<p>Sets the VSX system to Mute Auto Answer Calls mode. When this option is selected, the microphone pod is turned off to prevent the far site from hearing the near site when the VSX system is in Auto Answer mode.</p> <p>User interface screen location:  <b>System &gt; User Settings: Mute Auto Answer Calls</b></p>	<pre>muteautoanswer yes</pre>
soundeffectsvolume	<p><b>soundeffectsvolume &lt;set get test&gt;</b>  <b>soundeffectsvolume set &lt;{0..10}&gt;</b></p> <p>Where:</p> <ul style="list-style-type: none"> <li>• <b>set:</b> Sets the volume of sound effects. Requires a volume parameter in the range {0..10}.</li> <li>• <b>get:</b> Returns the current setting.</li> <li>• <b>test:</b> Tests the volume of sound effects.</li> </ul>	<p>Allows you to adjust and test the volume of the sounds made by the VSX system when an object on the screen is selected with the remote control.</p> <p>User interface screen location:  <b>System &gt; Admin Settings &gt; Audio: Sound Effects Volume</b></p>	<pre>soundeffectsvolu me set 6</pre>

Command	Syntax	Description	Example
subwoofer	<b>subwoofer &lt;on off get&gt;</b> Where: <ul style="list-style-type: none"> <li>• <b>on</b>: Turns the system subwoofer on.</li> <li>• <b>off</b>: Turns the system subwoofer off.</li> <li>• <b>get</b>: Returns the current setting (on or off).</li> </ul>	Specifies whether to use the system's subwoofer. (VSX 7000 only) User interface screen location: <b>System &gt; Admin Settings &gt; Audio</b> (page 3): <b>Subwoofer Speaker</b>	subwoofer on
volume	<b>volume &lt;set up down get&gt;</b> <b>volume set &lt;{0..50}&gt;</b> Where: <ul style="list-style-type: none"> <li>• <b>set</b>: Sets the volume to a specified level. Requires a volume setting from {0..50}.</li> <li>• <b>up</b>: Increases the audio volume by 1.</li> <li>• <b>down</b>: Decreases the audio volume by 1.</li> <li>• <b>get</b>: Returns the current volume level.</li> </ul>	Changes the call audio volume (not sound effects) on the VSX system. User interface screen location: <b>System &gt; Admin Settings &gt; Audio</b> (page 3): <b>Master Audio Volume</b>	volume set 10

## Call Commands



abk entries are entries stored on the VSX system. gabk entries are entries stored on the GDS. On the user interface screens, the Address Book and Global Address Book features are referred to as Directory and Global Directory.

Command	Syntax	Description	Example
abk	<p><b>abk &lt;batch all letter range refresh&gt;</b>  <b>abk batch &lt;{1..59}&gt;</b>  <b>abk letter &lt;{a..z}&gt;</b>  <b>abk range &lt;“n1”&gt;&lt;“n2”&gt;</b></p> <p>Where:</p> <ul style="list-style-type: none"> <li>• <b>batch:</b> Returns a batch of 10 records. Requires a batch number, which must be an integer in the range {1..59}.</li> <li>• <b>all:</b> Returns all the records in the Address Book.</li> <li>• <b>letter:</b> Returns entries beginning with the letter specified from the range {a..z}. Requires one or two alphanumeric characters. Valid characters are:            - _ / ; @ , . \            0 through 9            a through z</li> <li>• <b>range:</b> Returns local Address Book entries numbered “n1” through “n2”. Requires two integers.</li> <li>• <b>refresh:</b> Gets a more current copy of the Address Book/Global Directory.</li> </ul>	<p>Returns local Address Book entries.</p> <p>User interface screen location:  <b>Directory &gt; Search button or alphabet tabs</b></p>	<p>abk batch 0            Returns records 0 through 9.            abk range 2 8            Returns Address Book entries 2 through 8.</p>
alertuser-tone	<p><b>alertusertone &lt;1 2 3 4 get&gt;</b></p> <p>Where:</p> <ul style="list-style-type: none"> <li>• <b>1, 2, 3, or 4:</b> Sets the user alert to the corresponding tone.</li> <li>• <b>get:</b> Returns the current alert user tone setting (1, 2, 3, or 4).</li> </ul>	<p>Sets the tone used for user alerts.</p> <p>User interface screen location:  <b>System &gt; Admin Settings &gt; Audio: User Alert Tones</b></p>	<p>alertusertone 1</p>

Command	Syntax	Description	Example
alertvideo-tone	<p><b>alertvideotone &lt;1 2 3 4 5 6 7 8 9 10get&gt;</b></p> <p>Where:</p> <ul style="list-style-type: none"> <li>• <b>1, 2, 3, 4, 5, 6, 7, 8, 9, or 10:</b> Sets the incoming video alert to the corresponding tone.</li> <li>• <b>get:</b> Returns the current alert video tone setting (1, 2, 3, 4, 5, 6, or 7).</li> </ul>	<p>Sets the tone used for incoming video calls.</p> <p>User interface screen location:  <b>System &gt; Admin Settings &gt; Audio: Incoming Video Call</b></p>	<pre>alertusertone 8</pre>
allowmixed-calls	<p><b>allowmixedcalls &lt;yes no get&gt;</b></p> <p>Where:</p> <ul style="list-style-type: none"> <li>• <b>yes:</b> Enables mixed IP and ISDN calls.</li> <li>• <b>No:</b> Disables mixed IP and ISDN calls.</li> <li>• <b>get:</b> Returns the current setting (yes or no).</li> </ul>	<p>Sets or gets the ability to place and receive mixed protocol multipoint calls (IP and ISDN). It allows the administrator to disable this ability for security reasons.</p> <p>User interface screen location:  <b>System &gt; Admin Settings &gt; General Settings &gt; System Settings &gt; Call Settings: Allow Mixed IP and ISDN Calls</b></p> <p><b>Note:</b> This option is only visible on screen if ISDN and IP have both been enabled on the Call Preference screen.</p>	<pre>allowmixedcalls yes</pre>
allow-streaming	<p><b>allowstreaming &lt;yes no get&gt;</b></p> <p>Where:</p> <ul style="list-style-type: none"> <li>• <b>yes:</b> Allows streaming calls.</li> <li>• <b>no:</b> Disallows streaming calls.</li> <li>• <b>get:</b> Returns the current setting (yes or no).</li> </ul>	<p>Adds Streaming to the Utilities screen so that users can start streaming calls.</p> <p>User interface screen location:  <b>System &gt; Admin Settings &gt; Network &gt; IP &gt; Streaming: Allow Streaming</b></p>	<pre>allowstreaming yes</pre>
answer	<p><b>answer video</b></p> <p>Where:</p> <ul style="list-style-type: none"> <li>• <b>video:</b> Answers incoming video calls when the Auto Answer Point to Point or Auto Answer Multipoint option is set to No.</li> </ul>	<p>Answers incoming video calls.</p>	<pre>answer video</pre>

Command	Syntax	Description	Example
autoanswer	<p><b>autoanswer</b> <b>&lt;yes no donotdisturb get&gt;</b></p> <p>Where:</p> <ul style="list-style-type: none"> <li>• <b>yes:</b> Allows any incoming call to be connected automatically. This is the factory default setting.</li> <li>• <b>no:</b> Prompts the user to answer incoming calls.</li> <li>• <b>donotdisturb:</b> Notifies the user of incoming calls, but does not connect the call. The site that placed the call receives a Far Site Busy (H.320) or Call Rejected (H.323) code.</li> <li>• <b>get:</b> Returns the status of the option (yes, no, or donotdisturb).</li> </ul>	<p>Sets the Auto Answer Point to Point mode, which determines how the system will handle an incoming call in a point-to-point video conference.</p> <p>User interface screen location: <b>System &gt; Admin Settings &gt; General Settings &gt; System Settings &gt; Call Settings: Auto Answer Point to Point</b></p>	<pre>autoanswer donotdisturb</pre>
calldetailreport	<p><b>calldetailreport</b> <b>&lt;yes no get&gt;</b></p> <p>Where:</p> <ul style="list-style-type: none"> <li>• <b>yes:</b> Turns on call detail reporting.</li> <li>• <b>no:</b> Does not generate Call Detail Report.</li> <li>• <b>get:</b> Returns the current setting (yes or no).</li> </ul>	<p>Specifies whether to generate a report of all calls made with the system.</p> <p>User interface screen location: <b>System &gt; Admin Settings &gt; General Settings &gt; System Settings &gt; Call Settings</b> (page 2): <b>Call Detail Report</b></p>	<pre>calldetailreport yes</pre>
callencryption	<p><b>callencryption</b> <b>&lt;required disabled get&gt;</b></p> <p>Where:</p> <ul style="list-style-type: none"> <li>• <b>required:</b> Sets call encryption to be used for every call when it is available.</li> <li>• <b>disabled:</b> Disables call encryption.</li> <li>• <b>get:</b> Returns the current setting (required or disabled).</li> </ul>	<p>Sets or gets the encryption mode. Use encryption when the far site is capable of encryption.</p> <p>User interface screen location: <b>System &gt; Admin Settings &gt; General Settings &gt; Security: AES Encryption</b></p> <p><b>Note:</b> The Encryption options are only visible on the user interface if an encryption key has been entered.</p>	<pre>callencryption required</pre>
callpreference	<p><b>callpreference</b> <b>&lt;h320 h323 both get&gt;</b></p> <p>Where:</p> <ul style="list-style-type: none"> <li>• <b>h320:</b> Selects H.320 (ISDN) as the supported call type.</li> <li>• <b>h323:</b> Selects H.323 (IP) as the supported call type.</li> <li>• <b>both:</b> Selects both H.320 and H.323.</li> <li>• <b>get:</b> Returns the selected call types.</li> </ul>	<p>Specifies the supported call types (ISDN, IP, or both). After making a change, you must restart the system.</p> <p>User interface screen location: <b>System &gt; Admin Settings &gt; Network &gt; Call Preference: Enable IP H.323, Enable SIP, and Enable ISDN H.320</b></p>	<pre>callpreference h323</pre>

Command	Syntax	Description	Example
callstate	<p><b>callstate &lt;register unregister get&gt;</b></p> <p>Where:</p> <ul style="list-style-type: none"> <li>• <b>register</b>: Registers the system to give notification of call activities.</li> <li>• <b>unregister</b>: Disables the register mode.</li> <li>• <b>get</b>: Returns the selected call state mode (register or unregister).</li> </ul>	Registers the RS-232 session to receive notifications about call state activities.	<pre>callstate register  returns callstate registered  Acknowledgment that the session is now registered to list call state activities.  This is an example of the callstate data that may be returned after registering.  cs: call[0] chan[0] dialstr[IP:192.16 8.1.103] state [RINGING] cs: call[0] chan[0] dialstr[IP:192.16 8.1.103] state [RINGING] cs: call[0] chan[0] dialstr[IP:192.16 8.1.103] state [CONNECTED] cs: call[0] chan[0] dialstr[IP:192.16 8.1.103] state [COMPLETE] active: call[0] speed[128] cleared: call[0] line[0] bchan[0] cause[16] dialstr[IP:192.16 8.1.103] ended: call[0]</pre>

Command	Syntax	Description	Example
chaircontrol	<p><b>chaircontrol</b>  <b>&lt;rel_chair req_chair req_floor req_term_name req_vas view view_broadcaster list set_password set_broadcaster set_term_name hangup_term end_conf&gt;&lt;register unregister&gt;</b></p> <p>Subcommands:</p> <p><b>chaircontrol req_term_name</b>  <b>&lt;"term_no"&gt;</b></p> <p><b>chaircontrol &lt;view&gt;&lt;"term_no"&gt;</b></p> <p><b>chaircontrol</b>  <b>&lt;set_broadcaster&gt;&lt;"term_no"&gt;</b></p> <p><b>chaircontrol</b>  <b>&lt;set_term_name&gt;&lt;"term_no"&gt;</b>  <b>&lt;"term_name"&gt;</b></p> <p><b>chaircontrol</b>  <b>&lt;set_password&gt;&lt;meeting unique&gt;&lt;"unique string"&gt;</b></p> <p><b>chaircontrol</b>  <b>&lt;"hangup_term"&gt;&lt;"term_no"&gt;</b></p> <p>Where:</p> <ul style="list-style-type: none"> <li>• <b>rel_chair</b>: Releases the chair.</li> <li>• <b>req_chair</b>: Requests the chair.</li> <li>• <b>req_floor</b>: Requests the floor.</li> <li>• <b>req_term_name &lt;"term_no"&gt;</b>: Requests the terminal name for the specified terminal number.</li> <li>• <b>req_vas</b>: Requests voice-activated switching.</li> <li>• <b>view &lt;"term_no"&gt;</b>: Views the specified terminal.</li> <li>• <b>view_broadcaster</b>: Views the broadcaster.</li> <li>• <b>list</b>: Lists terminals in the conference.</li> <li>• <b>set_broadcaster &lt;"term_no"&gt;</b>: Requests the specified terminal to become the broadcaster.</li> <li>• <b>set_term_name &lt;"term_no"&gt;&lt;"term_name"&gt;</b>: Sets the terminal name of the specified terminal number.</li> <li>• <b>set_password &lt;"string"&gt;</b>: Sets the chaircontrol password. This password is the Meeting Password (<b>System &gt; Admin Setting &gt; General Settings &gt; Security: Meeting Password</b>).</li> </ul> <p>To clear the chaircontrol password, omit the parameter string.</p>	<p>Used for various chair control functions while the system is in a multipoint call.</p> <p>User interface screen location: When in a multipoint call, press the <b>NEAR</b> button on the remote control twice to bring up the Chair Control screen.</p>	<pre>chaircontrol req_term_name 2</pre>



Command	Syntax	Description	Example
chaircontrol (continued)	<ul style="list-style-type: none"> <li>• <b>“hangup_term” “term_no”</b>: Disconnects the specified terminal from the conference.</li> <li>• <b>end_conf</b>: Ends the conference.</li> <li>• <b>register</b>: Registers to receive feedback on all chair control operations.</li> <li>• <b>unregister</b>: Unregisters (stops feedback on all chair control operations). Use quotation marks around compound names and around strings that contain spaces. For example: “united states” or “111 222 333”.</li> </ul>		
dial	<p><b>dial &lt;addressbook manual&gt;</b>  <b>dial addressbook &lt;“name”&gt;</b>  <b>dial manual &lt;“speed”&gt; &lt;“dialstr1”&gt;</b>  <b>[“dialstr2”] [&lt;h323 h320 ip isdn&gt;</b></p> <p>Where:</p> <ul style="list-style-type: none"> <li>• <b>addressbook</b>: Dials an address book entry. Requires the name of the entry.</li> <li>• <b>manual</b>: Dials a video call number dialstr1 at speed of type h323 or h320 (the parameters ip and isdn are deprecated). Requires the parameters “speed” and “dialstr1”.</li> <li>• <b>“name”</b>: The name of the Address Book entry. The name may be up to 25 characters. Use quotation marks around strings that contain spaces. For example: “John Doe”.</li> </ul> <p>For <b>dial manual</b> parameter:</p> <ul style="list-style-type: none"> <li>• <b>“speed”</b>: Valid data rate for the network.</li> <li>• <b>“dialstr1”, “dialstr2”</b>: Valid ISDN or IP directory number.</li> <li>• <b>h323, h320, ip, isdn</b>: Type of call.</li> </ul> <p><b>Note:</b> The parameters ip and isdn are deprecated.</p>	Lets you dial video or audio calls either manually or from the Directory.	<pre>dial manual 2x64 5551212 5551213 h320 dial addressbook "Monday meeting"</pre>
dialchan- nels	<p><b>dialchannels &lt;set get&gt; &lt;1..N&gt;</b></p> <p>Where:</p> <ul style="list-style-type: none"> <li>• <b>set</b>: Sets the number of channels to dial.</li> <li>• <b>get</b>: Returns the current setting.</li> <li>• <b>1..N</b>: is number of ISDN lines. N is 8 for QBRI, 23 and 30 for the PRI.</li> </ul>	Lets you define how many ISDN channels are dialed in parallel. User interface screen location: <b>System &gt; Admin Settings &gt; Network &gt; ISDN</b>	dialchannels set 8

Command	Syntax	Description	Example
diffservaudio, diffservfecc, diffservvideo	<b>diffservaudio &lt;set get&gt;</b> <b>diffservaudio set &lt;{0..63}&gt;</b> <b>diffservfecc &lt;set get&gt;</b> <b>diffservfecc set &lt;{0..63}&gt;</b> <b>diffservvideo &lt;set get&gt;</b> <b>diffservvideo set &lt;{0..63}&gt;</b> Where: <ul style="list-style-type: none"> <li>• <b>set:</b> Sets the command. A priority level in the range {0..63} is required.</li> <li>• <b>get:</b> Returns the current setting.</li> </ul>	Lets you enable the DiffServ option and specify a priority level for audio, far-end camera control (FECC), and video, respectively. The priority level value for each can be between 0 and 63.  User interface screen location: <b>System &gt; Admin Settings &gt; Network &gt; IP &gt; Quality of Service: Type of Service &gt; DiffServ</b>	diffservaudio set 2
directory	<b>directory &lt;yes no get&gt;</b> Where: <ul style="list-style-type: none"> <li>• <b>yes:</b> Displays the directory button on the home screen.</li> <li>• <b>no:</b> Removes the directory button from the home screen.</li> <li>• <b>get:</b> Returns the current setting (yes or no).</li> </ul>	Specifies whether users can access the directory from the home screen.  User interface screen location: <b>System &gt; Admin Settings &gt; General Settings &gt; Home Screen Settings: Directory</b>	directory yes
farnametimedisplay	<b>farnametimedisplay &lt;on off "time" get&gt;</b> Where: <ul style="list-style-type: none"> <li>• <b>on:</b> Allows the near site to display the far site name for the duration of the call.</li> <li>• <b>off:</b> Disables the far site name display.</li> <li>• <b>"time":</b> Specifies the number of seconds to display the far site name at the beginning of a call. Valid values are: 15 30 60 120</li> <li>• <b>get:</b> Returns the current setting.</li> </ul>	returns the length of time the far-site name is to be displayed. User interface screen location: <b>System &gt; Admin Settings &gt; General Settings &gt; System Settings &gt; Call Settings (page 2): Far Site Name Display Time</b>	farnametimedisplay 60 farnametimedisplay off
gabk	<b>gabk &lt;batch all&gt;</b> <b>gabk batch &lt;{0..59}&gt;</b> Where: <ul style="list-style-type: none"> <li>• <b>batch:</b> Returns entries in batches. Must be followed by a value in the range {0..59}. The size of the batches is determined by the GAB server.</li> <li>• <b>all:</b> Returns all entries in the Global Directory.</li> </ul>	Returns Global Directory entries.	gabk batch 9 gabk batch all

Command	Syntax	Description	Example
gendial	<b>gendial</b> <{0..9 # *}> Where: <ul style="list-style-type: none"> <li>• <b>0..9</b>: generates the DTMF tone corresponding to a telephone's buttons, 0-9.</li> <li>• <b>#</b>: generates the DTMF tone corresponding to a telephone's # button.</li> <li>• <b>*</b>: generates the DTMF tone corresponding to a telephone's * button.</li> </ul>	Generates DTMF dialing tones over a video call.  User interface screen location: On the near or far video screen, press <b>#</b> on the remote control to access a keypad for generating tones.	<b>gendial 2</b>  generates the DTMF tone corresponding to a telephone's 2 button over a video call.
gential- tonepots	<b>gentialtonepots</b> ["buttons"] Where: <ul style="list-style-type: none"> <li>• <b>"buttons"</b>: Valid buttons are: 0..9, #, and *.</li> </ul>	Generates DTMF dialing tones over a POTS line.  <b>Note:</b> To generate DTMF tones over video, use the command <b>gential</b> instead.	<b>gentialtonepots 2</b>  generates the DTMF tone corresponding to a telephone's 2 button over a POTS line.
hangup	<b>hangup video</b> [{1..3}] Where: <ul style="list-style-type: none"> <li>• <b>hangup</b>: Hangs up the current call. If it is a multipoint call, this disconnects the system from all other endpoints in the call if the <b>"call"</b> parameter is not used.</li> <li>• <b>{1..3}</b>: Selects which call in a multipoint call to hang up. The number corresponds to the order in which endpoints were connected to the call.</li> </ul>	Hangs up the current video call.	<b>hangup video 2</b>  disconnects the second endpoint that was added to the call, while leaving other endpoints connected.

Command	Syntax	Description	Example
ipdialspeed	<p><b>ipdialspeed &lt;set get&gt;&lt;“valid speed”&gt;&lt;on off&gt;</b></p> <p>Where:</p> <ul style="list-style-type: none"> <li>• <b>set:</b> Sets the IP dialing speed. The parameters “valid speed” and on or off are required.</li> <li>• <b>get:</b> Returns the current setting (on or off). The parameter “valid speed” is required.</li> <li>• <b>“valid speed”:</b> Valid speeds are: 56, 64, 2x56, 112, 2x64, 128, 168, 192, 224, 256, 280, 320, 336, 384, 392, 7x64, 8x56, 504, 512, 560, 576, 616, 640, 672, 704, 728, 768, 784, 832, 840, 16x56, 14x64, 952, 960, 1008, 1024, 1064, 1088, 1120, 1152, 1176, 1216, 1232, 1280, 1288, 24x56, 21x64, 1400, 1408, 1456, 1472, 1512, 1536, 1568, 1600, 1624, 1664, 1680, 1728, 1736, 32x56, 28x64, 1848, 1856, 1904, and 1920 kbps.</li> <li>• <b>on:</b> Enables the specified speed.</li> <li>• <b>off:</b> Disables the specified speed.</li> </ul>	<p>Sets or gets the valid IP dialing speed, and enables or disables the specified speed.</p> <p>User interface screen location:  <b>System &gt; Admin Settings &gt; Network &gt; Call Preference</b>            (page 3): <b>Preferred Speeds</b></p>	<pre>ipdialspeed get 168 returns: ipdialspeed 168 off</pre>
ipisdninfo	<p><b>ipisdninfo &lt;both ip-only isdn-only none get&gt;</b></p> <p>Where:</p> <ul style="list-style-type: none"> <li>• <b>both:</b> Displays IP and ISDN information on the Home screen.</li> <li>• <b>ip-only:</b> Displays only IP information on the Home screen.</li> <li>• <b>isdn-only:</b> Displays only ISDN information on the Home screen.</li> <li>• <b>none:</b> Does not display any IP or ISDN information on the Home screen.</li> <li>• <b>get:</b> Returns the current setting (both, ip-only, or isdn-only, or none).</li> </ul>	<p>Determines whether the home screen displays IP information, ISDN information, both, or neither.</p> <p>User interface screen location:  <b>System &gt; Admin Settings &gt; General Settings &gt; Home Screen Settings</b> (page 2): <b>IP or ISDN Information</b></p>	<pre>ipisdninfo ip-only</pre>
isdnarea-code	<p><b>isdnareacode &lt;set get&gt; ["area code"]</b></p> <p>Where:</p> <ul style="list-style-type: none"> <li>• <b>set:</b> Sets the ISDN area code when followed by the “area code” parameter. To erase the current setting, omit “area code”.</li> <li>• <b>get:</b> Returns the area code information.</li> <li>• <b>“area code”:</b> Numeric value.</li> </ul>	<p>Sets or gets the ISDN area code or STD code associated with the area where the system is used.</p> <p>User interface screen location:  <b>System &gt; Admin Settings &gt; Network &gt; ISDN: Area Code</b></p> <p><b>Note:</b> This screen is only accessible if you have a Quad BRI network interface connected to your system.</p>	<pre>isdnareacode set 512</pre>

Command	Syntax	Description	Example
isdndial-speed	<p><b>isdndialspeed &lt;set get&gt;&lt;“valid speed”&gt;&lt;on off&gt;</b></p> <p>Where:</p> <ul style="list-style-type: none"> <li>• <b>set</b>: Sets the ISDN dialing speed. The parameters “valid speed” and on or off are required.</li> <li>• <b>get</b>: Returns the current setting (on or off). The parameter “valid speed” is required.</li> <li>• <b>“valid speed”</b>: Valid speeds are: 56, 2x56, 112, 168, 224, 280, 336, 392, 64, 8x56, 2x64, 128, 192, 256, 320, 384, 7x64, 512, 560, 576, 616, 640, 672, 704, 728, 768, 784, 832, 840, 14x64, 952, 960, 1008, 1024, 1064, 1088, 1120, 1152, 1176, 1216, 1232, 1280, 1288, 21x64, 1400, 1408, 1456, 1472, 1512, 1536, 1568, 1600, 1624, 1664, 1680, 1728, 28x64, 1856, and 1920 kbps.</li> </ul> <p><b>Note:</b> The highest speed for BRI systems is 512 kbps, the highest speed for T1 systems is 1472 kbps, and the highest speed for E1 systems is 1920 kbps.</p> <ul style="list-style-type: none"> <li>• <b>on</b>: Enables the specified speed.</li> <li>• <b>off</b>: Disables the specified speed.</li> </ul>	<p>Enables or disables the valid dialing speed of the ISDN network interface.</p> <p>User interface screen location: <b>System &gt; Admin Settings &gt; Network &gt; Call Preference</b> (page 5): <b>Call Speeds</b></p> <p><b>Note:</b> This screen is only accessible if you have a Quad BRI, PRI, or V.35 network interface connected to your system.</p>	<pre>isdndialspeed set 256 on</pre>
linestate	<p><b>linestate &lt;register unregister&gt;</b></p> <p>Where:</p> <ul style="list-style-type: none"> <li>• <b>register</b>: Registers to receive notification when IP or ISDN line states change.</li> <li>• <b>unregister</b>: Unregisters to receive notification when IP or ISDN line states change.</li> </ul>	<p>Registers the API session to receive notifications about IP or ISDN line state changes.</p> <p><b>Note:</b> This screen is only accessible if you have a Quad BRI, PRI, or V.35 network interface connected to your system.</p>	<pre>linestate register</pre>
maxgabinternationalcallspeed	<p><b>maxgabinternationalcallspeed &lt;set get&gt;&lt;“valid speed”&gt;</b></p> <p>Where:</p> <ul style="list-style-type: none"> <li>• <b>set</b>: Sets the maximum speed for international calls when followed by a valid speed value.</li> <li>• <b>get</b>: Returns the current valid speed.</li> <li>• <b>“valid speed”</b>: Valid speeds are: 2x64, 128, 256, 384, 512, 768, 1024, and 1472 kbps.</li> </ul>	<p>Sets or gets the maximum speed for international ISDN calls made from the Global Directory.</p>	<pre>maxgabinternational callspeed set 512</pre>

Command	Syntax	Description	Example
maxgabinternetcallspeed	<p><b>maxgabinternetcallspeed &lt;set get&gt;&lt;“valid speed”&gt;</b></p> <p>Where:</p> <ul style="list-style-type: none"> <li>• <b>set</b>: Sets the maximum speed for Internet calls when followed by a valid speed value.</li> <li>• <b>get</b>: Returns the current valid speed.</li> <li>• <b>“valid speed”</b>: Valid speeds are: 128, 256, 384, 512, 768, 1024, and 1472 kbps.</li> </ul>	Sets or gets the maximum speed for Internet (IP/H.323) calls made from the Global Directory.	maxgabinternetcallspeed set 384
maxgabisdncallspeed	<p><b>maxgabisdncallspeed &lt;set get&gt;&lt;“valid speed”&gt;</b></p> <p>Where:</p> <ul style="list-style-type: none"> <li>• <b>set</b>: Sets the maximum speed for ISDN calls when followed by a valid speed value.</li> <li>• <b>get</b>: Returns the current valid speed.</li> <li>• <b>“valid speed”</b>: Valid speeds are: 2x64, 128, 256, 384, 512, 768, 1024, and 1472 kbps.</li> </ul>	Sets or gets the maximum speed for ISDN (H.320) calls made from the Global Directory.  User interface screen location: <b>System &gt; Admin Settings &gt; Network &gt; Call Preference</b> (page 4): <b>ISDN Video Calls (H.320)</b>	maxgabisdncallspeed set 384
maxtimeincall	<p><b>maxtimeincall &lt;set get&gt; [“time”]</b></p> <p>Where:</p> <ul style="list-style-type: none"> <li>• <b>set</b>: Sets the maximum time for calls when followed by a parameter from {0..999}.</li> </ul> <p>To erase the current setting, omit the time parameter. The call will then stay up indefinitely.</p> <ul style="list-style-type: none"> <li>• <b>get</b>: Returns the current setting.</li> <li>• <b>“time”</b>: Maximum call time in minutes. Must be an integer in the range {0..999}.</li> </ul>	Sets the maximum number of minutes allowed for call length. When that time has expired in a call, a message asks you if you want to hang up or stay in the call. If you do not answer within one minute, the call automatically disconnects.  User interface screen location: <b>System &gt; Admin Settings &gt; General Settings &gt; System Settings &gt; Call Settings: Maximum Time in Call</b>	maxtimeincall set 180
meetingpassword	<p><b>meetingpassword &lt;set get&gt; [“password”]</b></p> <p>Where:</p> <ul style="list-style-type: none"> <li>• <b>set</b>: Sets the meeting password if followed by the password parameter.</li> </ul> <p>To erase the current setting, omit the password parameter.</p> <ul style="list-style-type: none"> <li>• <b>get</b>: Returns the current meeting password.</li> <li>• <b>“password”</b>: User-defined password. Valid characters are: A through Z (lower and uppercase), -, _, @, /, ;, ,, ., \, and 0 through 9. The length is limited to 10 characters. Use quotation marks around the password string if it contains spaces.</li> </ul>	Sets the meeting password.  User interface screen location: <b>System &gt; Admin Settings &gt; General Settings &gt; Security: Meeting Password</b>	meetingpassword set VSXpasswd

Command	Syntax	Description	Example
mpautoanswer	<p><b>mpautoanswer</b> <b>&lt;yes no donotdisturb get&gt;</b></p> <p>Where:</p> <ul style="list-style-type: none"> <li>• <b>yes</b>: Connects incoming calls automatically. The screen will split into a multipoint call progress screen as the incoming call is answered.</li> <li>• <b>no</b>: User Interface: For an incoming call, the user will be notified and given the choice to answer the call. If the user selects Yes, the call is added to the ongoing conference. If the user selects No, the call is rejected. The factory default is No. API: For an incoming call, if the <b>listen video</b> command has been issued, the string "listen video ringing" will be returned in the RS-232 session.</li> <li>• <b>donotdisturb</b>: The user is not notified of incoming calls. The sites that placed the calls receive a Far Site Busy (H.320) or Call Rejected (H.323) code.</li> <li>• <b>get</b>: Returns the status of the option (yes, no, or donotdisturb).</li> </ul>	<p>Sets the Auto Answer Multipoint mode, which determines how the system will handle an incoming call in a multipoint video conference.</p> <p>User interface screen location: <b>System &gt; Admin Settings &gt; General Settings &gt; System Settings &gt; Call Settings: Auto Answer Multipoint or System &gt; User Settings: Auto Answer Multipoint</b></p>	<pre>mpautoanswer donotdisturb</pre>

Command	Syntax	Description	Example
mpmode	<p><b>mpmode</b>  <b>&lt;auto discussion presentation full screen get&gt;</b></p> <p>Where:</p> <ul style="list-style-type: none"> <li>• <b>auto:</b> In Auto mode, the system switches between Full Screen Mode and Discussion mode, depending on the interaction between the sites. If one site is talking uninterrupted for 15 seconds or more, the speaker appears full screen.</li> <li>• <b>presentation:</b> In Presentation mode, the person who is speaking appears full screen to the far sites, while the person who is speaking sees all the other sites on a split screen.</li> <li>• <b>discussion:</b> In Discussion mode (also called Continuous Presence mode), every site sees all the sites in the meeting at the same time, on a split screen.</li> <li>• <b>fullscreen:</b> In Full Screen mode, every site in the call sees the current speaker, or the latest person to speak, on the full screen.</li> <li>• <b>get:</b> Returns the current setting for this option.</li> </ul>	<p>Sets or gets the multipoint conference viewing mode for the system in a multipoint call. The multipoint mode can be set to auto, discussion, presentation, or fullscreen. By default, it is set to auto.</p> <p>User interface screen location:  <b>System &gt; Admin Settings &gt; Monitors &gt; Multipoint Setup: Multipoint Mode</b></p>	mpmode discussion
numdigits-did	<p><b>numdigitsdid &lt;{0..99} get&gt;</b></p> <p>Where:</p> <ul style="list-style-type: none"> <li>• <b>{0..99}:</b> Specifies the number of digits in DID numbers.</li> <li>• <b>get:</b> Returns the current setting.</li> </ul>	<p>Sets the number of digits in the DID Gateway number (E.164 dialing). The number of digits in the DID is that portion of the full DID that the Gateway will be given from the ISDN service provider as the Called Party Line Identifier. This, in turn, will be passed to the Gatekeeper for address resolution.</p> <p>User interface screen location:  <b>System &gt; Admin Settings &gt; Network &gt; IP &gt; H.323 Settings (page 4): Number of Digits in DID Number</b></p> <p><b>Note:</b> For this option to be available, the <b>Gateway Number Type</b> on the same page must be set to Direct Inward Dial.</p>	numdigitsdid 7



Command	Syntax	Description	Example
numdigit-sext	<p><b>numdigitsext &lt;{0..99} get&gt;</b></p> <p>Where:</p> <ul style="list-style-type: none"> <li>• <b>{0..99}</b>: The number of digits in the gateway number if <b>gatewaynumbertype</b> is set to <b>number+extension</b>.</li> <li>• <b>get</b>: Returns the current setting.</li> </ul>	<p>Sets the number of digits in the Number+Extension Gateway number (E.164 dialing). The number of digits in that number is that portion of the full Number+Extension number that the Gateway will be given from the ISDN service provider as the Called Party Line Identifier. This, in turn, will be passed to the Gatekeeper for address resolution.</p> <p>User interface screen location:  <b>System &gt; Admin Settings &gt; Network &gt; IP &gt; H.323 Settings</b> (page 4): <b>Number of Digits in Extension</b></p>	numdigitsext 10
outbound-callroute	<p><b>outboundcallroute &lt;gateway isdn get&gt;</b></p> <p>Where:</p> <ul style="list-style-type: none"> <li>• <b>gateway</b>: Use if your outbound call needs to be handled by a gateway.</li> <li>• <b>isdn</b>: Use if your VSX system is connected to an ISDN line. ISDN is the default.</li> <li>• <b>get</b>: Returns the current setting (gateway or isdn).</li> </ul>	<p>Sets the default outbound calling route.</p> <p>User interface screen location:  <b>System &gt; Admin Settings &gt; Network &gt; IP &gt; H.323 Settings</b> (page 2): <b>Outbound Call Route</b></p>	outboundcallroute gateway
phone	<p><b>phone &lt;flash clear&gt;</b></p> <p>Where:</p> <ul style="list-style-type: none"> <li>• <b>flash</b>: Switches the phone channel to the next channel to add another telephone call to your video call.</li> <li>• <b>clear</b>: Clears any dialstring from the text box on the Telephone screen.</li> </ul>	<p>Either switches the phone channel to the next channel to add another telephone call to a video call, or clears any dialstring from the text box on the Telephone screen of the user interface.</p> <p>User interface screen location:  <b>Telephone &gt; Flash button and Clear button</b></p>	phone flash

Command	Syntax	Description	Example
pip	<p><b>pip &lt;on off auto swap get&gt;</b></p> <p>Where:</p> <ul style="list-style-type: none"> <li>• <b>on</b>: Enables PIP mode. The VSX system shows a PIP window that remains in the lower right corner of the screen until the video call is completed.</li> <li>• <b>off</b>: Disables PIP mode.</li> <li>• <b>auto</b>: The VSX system shows a PIP window when the call is first connected and when the remote control is not resting on a flat surface.</li> <li>• <b>swap</b>: Toggles the content of the PIP and the main display between the near-site and far-site view.</li> <li>• <b>get</b>: Returns the current setting for PIP mode (on, off, or auto).</li> </ul>	<p>Sets the on-screen PIP mode. The PIP feature allows the near site to adjust near-camera views while in a video conference.</p> <p>User interface screen location:  <b>System &gt; Admin Settings &gt; Monitors &gt; Monitors: PIP</b></p> <p>or</p> <p><b>System &gt; User Settings</b> (page 2): <b>PIP</b></p> <p><b>Note:</b> The Allow Access to User Settings option under <b>System &gt; Admin Settings &gt; General Settings &gt; Security</b> (page 2) must be checked for the User Settings option to be available.</p>	<p>pip auto</p>
recentcalls	<b>recentcalls</b>	<p>View the list of recent calls.</p> <p>User interface screen location:  <b>System &gt; Admin Settings &gt; Network &gt; Recent Calls</b></p>	<p>recentcalls might return something like this:</p> <pre>"Austin Oasis" 16/Jun/2004 14:39:56      Out Sooners 16/Jun/2004 14:40:07      Out A    16/Jun/2004 14:40:35      Out 4136419 16/Jun/2004 20:27:33      Out 4136419 16/Jun/2004 20:28:37      Out "POLYCOM MGC" 17/Jun/2004 02:13:23      In 209.163.168.122 17/Jun/2004 02:20:08      In "POLYCOM MGC" 17/Jun/2004 02:21:40      In "POLYCOM MGC" 17/Jun/2004 05:53:04      In "POLYCOM MGC" 17/Jun/2004 07:00:19      In</pre>

Command	Syntax	Description	Example
rs366dialing	<b>rs366dialing &lt;on off get&gt;</b> Where: <ul style="list-style-type: none"> <li>• <b>on</b>: Enables RS-366 dialing.</li> <li>• <b>off</b>: Disables RS-366 dialing.</li> <li>• <b>get</b>: Returns the current setting (on or off).</li> </ul>	Sets or gets RS-366 dialing. Enable this option if you want to call from the system through the DCE connection to the far-site video conferencing system. Disable this option if you are using your DCE to dial the call or if you have a dedicated connection to the far site.  User interface screen location: <b>System &gt; Admin Settings &gt; Network &gt; V.35/RS-449/RS-530: RS-366 Dialing.</b>	rs366dialing on
requireacctnumtodial	<b>requireacctnumtodial &lt;yes no get&gt;</b> Where: <ul style="list-style-type: none"> <li>• <b>yes</b>: Enables the option.</li> <li>• <b>no</b>: Disables the option.</li> <li>• <b>get</b>: Returns the current setting (yes or no).</li> </ul>	Enables or disables the Require Account Number to Dial option. It is used to log calls to a specific account so that they can be tracked and billed to the appropriate departments. When this option is selected, you cannot make a call without first entering an account number. This account number is saved in the GMS server database along with information specific to the call. Typically, the GMS administrator assigns the account number.  User interface screen location: <b>System &gt; Admin Settings &gt; Global Services &gt; Account Validation: Require Account Number to Dial</b>	requireacctnumtodial yes
roomphonenumber	<b>roomphonenumber &lt;set get&gt; ["number"]</b> Where: <ul style="list-style-type: none"> <li>• <b>set</b>: Sets the room phone number when followed by the "number" parameter. To erase the current setting, omit the "number" parameter.</li> <li>• <b>get</b>: Returns the current setting.</li> <li>• <b>"number"</b>: Telephone number for a telephone (not the VSX system) in the room. Use quotation marks around the number if it contains spaces. For example: "512 555 1212".</li> </ul>	Lets you enter the number of the phone that is located in the same room as the VSX system. If the system is managed by the Global Management System (GMS) software, this number will be provided to the GMS administrator if the person using the VSX system requests help.  User interface screen location: <b>System &gt; Admin Settings &gt; General Settings &gt; Location: Room Telephone Number</b>	roomphonenumber "512 5551212"

Command	Syntax	Description	Example
setaccount-number	<p><b>setaccountnumber</b> &lt;"account"&gt;</p> <p>Where:</p> <ul style="list-style-type: none"> <li>• <b>"account"</b>: Number that is needed to validate the account before dialing out.</li> </ul>	<p>Sets the account number that is required for dialing out. The account number is saved in the GMS database and is generally assigned by the GMS administrator. The option Required Account to Dial must be enabled for this command to work. When you make a call, you will be prompted to enter your account number. See the related <a href="#">requireacctnumdial</a> command on page 3-35.</p>	<pre>setaccountnumber 1234</pre>
system-name	<p><b>systemname</b> &lt;set get&gt; ["name"] <b>systemname set</b> ["system name"]</p> <p>Where:</p> <ul style="list-style-type: none"> <li>• <b>set</b>: Sets the system name when followed by the "name" parameter. To erase the current setting, omit the "name" parameter.</li> <li>• <b>get</b>: Returns the current setting for this option.</li> <li>• <b>name</b>: Character string specifying the system name. Enclose the string in quotation marks if it includes spaces. Example: "Pacific Room"</li> </ul>	<p>Sets the name of the VSX system. The first character must be a numeric (a digit) or alphabetic (a letter) character including foreign language characters. The name can be any combination of alphanumeric characters and may be up to 34 characters in length. The system name cannot be blank.</p> <p>User interface screen location: <b>System &gt; Admin Settings &gt; General Settings &gt; System Settings &gt; Directory: System Name</b></p>	<pre>systemname set MyOwnVSX systemname set "Pacific Room"</pre>
telearea-code	<p><b>teleareacode</b> &lt;set get&gt; ["area code"]</p> <p>Where:</p> <ul style="list-style-type: none"> <li>• <b>set</b>: Sets the telephone number when followed by the "telephone number" parameter. To erase the current setting, omit the parameter.</li> <li>• <b>get</b>: Returns the current setting.</li> <li>• <b>"area code"</b>: System's area code.</li> </ul>	<p>Sets or gets the system's area code.</p>	<pre>teleareacode set 555</pre>

Command	Syntax	Description	Example
telecountry-code	<p><b>telecountrycode &lt;set get&gt; ["telephone country code"]</b></p> <p>Where:</p> <ul style="list-style-type: none"> <li>• <b>set</b>: Sets the telephone country code when followed by the "telephone country code" parameter. To erase the current setting, omit the parameter.</li> <li>• <b>get</b>: Returns the country code information.</li> <li>• <b>"telephone country code"</b>: Numeric value. This code is the same as the ISDN country code.</li> </ul>	<p>Sets or gets the system's telephone country code. This code is associated with the country where the system is used. The system is generally able to automatically determine the country code based on the country you selected during initial system setup.</p> <p>User interface screen location:  <b>System &gt; Admin Settings &gt; General Settings &gt; Location: Country Code</b></p> <p><b>Note:</b> This option is automatically set by the Country.</p>	<pre>telecountrycode set 33</pre>
telenumber	<p><b>telenumber &lt;set get&gt; ["telephone number"]</b></p> <p>Where:</p> <ul style="list-style-type: none"> <li>• <b>set</b>: Sets the telephone number when followed by the "telephone number" parameter. To erase the current setting, omit the parameter.</li> <li>• <b>get</b>: Returns the current setting.</li> <li>• <b>"telephone number"</b>: System's telephone number. Enclose the string in quotation marks if it includes spaces. Example: "512 555 1212"</li> </ul>	<p>Sets or gets the system's telephone number.</p> <p>User interface screen location:  <b>System &gt; Admin Settings &gt; Network &gt; Telephony: Room Telephone Number</b></p>	<pre>telenumber set 5551212</pre>
validateacctnum	<p><b>validateacctnum &lt;yes no get&gt;</b></p> <p>Where:</p> <ul style="list-style-type: none"> <li>• <b>yes</b>: Enables the GMS account number validation option.</li> <li>• <b>no</b>: Disables the GMS account number validation option.</li> <li>• <b>get</b>: Returns the current setting (yes or no).</li> </ul>	<p>Sets the validation for the GMS account number that is used when dialing out. When the call connects, the VSX system verifies that the account exists with the Global Management System (GMS) server. If the account does not exist, the call is disconnected.</p> <p>User interface screen location:  <b>System &gt; Admin Settings &gt; Global Services &gt; Account Validation: Validate Account Number</b></p> <p><b>Note:</b> This option is only available if the <b>Required Account Number to Dial</b> is enabled.</p>	<pre>validateacctnum yes</pre>

Command	Syntax	Description	Example
vbutton	<p><b>vbutton</b>  <b>&lt;play stop get register unregister</b>  <b>&gt;</b></p> <p>Where:</p> <ul style="list-style-type: none"> <li>• <b>play:</b> Starts sending the video stream from the Visual Concert™ VSX.</li> <li>• <b>stop:</b> Stops sending the video stream from the Visual Concert VSX.</li> <li>• <b>get:</b> Returns the current mode/setting (play or stop).</li> <li>• <b>register:</b> Registers the shell session to receive notifications about Visual Concert VSX events.</li> <li>• <b>unregister:</b> Unregisters the shell session to receive notifications about Visual Concert VSX events.</li> </ul>	<p>Simulates the Visual Concert VSX play and stop buttons. It can also register or unregister to receive notification of Visual Concert VSX events.</p>	<pre>vbutton play</pre>
volume	<p><b>volume &lt;set up down get&gt;</b>  <b>volume set &lt;{0..50}&gt;</b></p> <p>Where:</p> <ul style="list-style-type: none"> <li>• <b>set:</b> Sets the volume to a specified level. Requires a volume setting from {0..50}.</li> <li>• <b>up:</b> Increases the audio volume by 1.</li> <li>• <b>down:</b> Decreases the audio volume by 1.</li> <li>• <b>get:</b> Returns the current volume level.</li> </ul>	<p>Changes the call audio volume (not sound effects) on the VSX system.</p> <p>User interface screen location:  <b>System &gt; Admin Settings &gt; Audio</b> (page 3): <b>Master Audio Volume</b></p>	<pre>volume set 10</pre>

## Camera Control Commands

Command	Syntax	Description	Example
camera	<p><b>camera</b>  <b>&lt;near far register unregister&gt;</b>  <b>camera &lt;register unregister&gt;</b>  <b>camera near</b>  <b>&lt;{1..4} source move stop&gt;</b>  <b>camera far</b>  <b>&lt;{1..5} source move stop tracking</b>  <b>&gt;</b>  <b>camera &lt;near far&gt; move</b>  <b>&lt;zoom+ zoom- left right up down </b>  <b>stop continuous discrete&gt;</b>  <b>camera far tracking</b>  <b>&lt;on off to _presets get&gt;</b></p> <p>Where:</p> <ul style="list-style-type: none"> <li>• <b>register</b>: Registers to receive feedback when the user changes the camera source.</li> <li>• <b>unregister</b>: Unregisters to receive feedback when the user changes the camera source.</li> <li>• <b>near</b>: Specifies that the command selects or controls the near camera.</li> <li>• <b>far</b>: Specifies that the command selects or controls the far camera.</li> </ul> <p>For <b>camera &lt;near far&gt;</b> parameter:</p> <ul style="list-style-type: none"> <li>• <b>{1..4}, {1..5}</b>: Specifies a near or far camera as the main video source.</li> <li>• <b>source</b>: Returns the number of the near or far camera source currently selected.</li> <li>• <b>move &lt;direction&gt;</b>: Changes the near or far camera's direction or zoom. Valid directions are: <ul style="list-style-type: none"> <li>□ <b>continuous</b>: Selects continuous movement mode. The camera will move in direction specified until a <b>camera &lt;near far&gt; move stop</b> command is sent.</li> <li>□ <b>discrete</b>: Selects discrete movement mode. The camera will move a small amount in the direction specified and then stop. No <b>stop</b> command is required.</li> </ul> </li> </ul>	<p>Controls the position and zoom of the near-site camera, and the view (camera input) that is presented.</p>	<p><code>camera far 2</code>  causes the remote terminal to begin sending its camera 2.</p> <p><code>camera far move left</code>  causes the far camera to start panning to the left.</p> <p><code>camera near move zoom+</code>  causes the near camera to zoom in.</p>

Command	Syntax	Description	Example
camera (continued)	<ul style="list-style-type: none"> <li>❑ <b>left</b>: Starts moving the camera to the left.</li> <li>❑ <b>right</b>: Starts moving the camera to the right.</li> <li>❑ <b>up</b>: Starts moving the camera up.</li> <li>❑ <b>down</b>: Starts moving the camera down.</li> <li>❑ <b>zoom-</b>: Starts zooming out.</li> <li>❑ <b>zoom+</b>: Starts zooming in.</li> <li>❑ <b>stop</b>: Stops the camera motion in progress.</li> <li>• <b>near &lt;setposition getposition&gt;</b>: Sets or gets the x, y, and z coordinates of the currently selected PTZ camera. Camera PTZ range: <ul style="list-style-type: none"> <li>-880 &lt;= x &lt;= 880 (pan)</li> <li>-300 &lt;= y &lt;= 300 (tilt)</li> <li>0 &lt;= z &lt;= 1023 (zoom)</li> </ul> <p><b>Note:</b> Some D30 cameras might not be able to reach the designed range limit. For example, although the pan limit is 880, the camera might only be able to reach 860.</p> </li> <li>• <b>stop</b>: Stops the near or far camera when in continuous mode.</li> <li>• <b>tracking</b>: Tracking mode: <ul style="list-style-type: none"> <li>❑ <b>on</b>: Turns on the far camera tracking mode. The far-site system must have the option Far Control of Near Camera enabled and auto-tracking turned on.</li> <li>❑ <b>off</b>: Turns off the far camera tracking mode.</li> <li>❑ <b>to_presets</b>: Turns on the far camera tracking to presets.</li> <li>❑ <b>get</b>: Returns the far camera tracking mode.</li> </ul> </li> </ul>		
cameradi- rection	<p><b>cameradirection &lt;normal reversed get&gt;</b></p> <p>Where:</p> <ul style="list-style-type: none"> <li>• <b>normal</b>: Sets the direction of the camera to normal.</li> <li>• <b>reversed</b>: Sets the direction of the camera to reversed.</li> <li>• <b>get</b>: Returns the current setting (normal or reversed).</li> </ul>	<p>Selects whether the camera moves in the same direction (normal) as the arrows on the remote control or in the opposite (reversed) direction.</p> <p>User interface screen location:  <b>System &gt; Admin Settings &gt; Cameras: Camera Direction</b></p>	<pre>cameradirection normal</pre>



Command	Syntax	Description	Example
farcontrol-nearcamera	<b>farcontrolnearcamera &lt;yes no get&gt;</b> Where: <ul style="list-style-type: none"> <li>• <b>yes</b>: Allows the far site to control the near camera if the far site has this capability.</li> <li>• <b>no</b>: Disables far control of the near camera.</li> <li>• <b>get</b>: Returns the current setting.</li> </ul>	Sets far control of the near camera, thus allowing remote sites to control the camera on your VSX system.  User interface screen location: <b>System &gt; Admin Settings &gt; Cameras: Far Control of Near Camera</b>	<pre>farcontrolnear-camera yes</pre>
preset	<b>preset &lt;register unregister near far&gt;</b> <b>preset &lt;near far&gt;&lt;set go&gt;&lt;"preset"&gt;</b> Where: <ul style="list-style-type: none"> <li>• <b>register</b>: Registers the system to give notification when the user sets or goes to presets.</li> <li>• <b>unregister</b>: Disables register mode.</li> <li>• <b>near</b>: Specifies the near camera. Requires a set or go parameter and a preset identifier.</li> <li>• <b>far</b>: Specifies the far camera. Requires a set or go parameter and a preset identifier.</li> </ul> For <b>preset &lt;near far&gt;</b> parameter: <ul style="list-style-type: none"> <li>• <b>set</b>: Sets a camera preset. Requires a "preset" parameter.</li> <li>• <b>go</b>: Moves the camera to a camera preset. Requires a "preset" parameter.</li> <li>• <b>"preset"</b>: Camera preset identifier. Must be an integer in the range {0..29}. While the user interface provides ten presets (0-9), the API provides 30.</li> </ul>	Sets the presets or goes (moves) to the presets for the near or far camera source. Also registers or unregisters the RS-232 session to give notification when the user sets or goes to presets. Up to ten preset camera positions can be set. These ten camera presets can be distributed across the far camera and up to four near-site cameras.	<pre>preset near set 2</pre> <p>The current location/ position of the near-site camera is saved as preset 2.</p>
primary-camera	<b>primarycamera &lt;{1..4} get&gt;</b> Where: <ul style="list-style-type: none"> <li>• <b>{1..4}</b>: Selects the camera to use as the primary video source.</li> <li>• <b>get</b>: Returns the number of the camera currently designated as the primary camera.</li> </ul>	Sets the primary camera that is used when the VSX system powers on. You cannot disconnect the main camera, but you do not have to set it as the primary camera.  User interface screen location: <b>System &gt; Admin Settings &gt; Cameras: Primary Camera</b>	<pre>primarycamera 1</pre>

## Diagnostics and Statistics Commands

Command	Syntax	Description	Example
advnetstats	<p><b>advnetstats [{0..2}]</b></p> <p>Where:</p> <ul style="list-style-type: none"> <li><b>0..2:</b> Calls in a multipoint call, where 0 is call #1, 1 is call #2, and 2 is call #3. Select a number from this range to specify a remote site call for which you want to obtain advanced network statistics.</li> </ul> <p>Omit this parameter when retrieving statistics for a point-to-point call</p>	<p>Gets advanced network statistics for a call.</p> <p>User interface screen location: <b>System &gt; Diagnostics &gt; Call Statistics</b></p>	<pre>advnetstats 1 returns: call:1 tar:24k rar:24k tvr:64.3k rvr:104k tvru:63.8k rvru:114.6k tvfr:15.0 rvfr:15.0 vfe --- tapl:66 rapl:0 taj:46mS raj:40mS tvpl:122 rvpl:0 tvj:21mS rvj:60mS dc:--- rsid:Polycom_4.2</pre> <p>Returned parameters are:</p> <p>tar Transmit audio rate</p> <p>rar Receive audio rate</p> <p>tvr Transmit video rate</p> <p>rvr Receive video rate</p> <p>tvru Transmit video rate used</p> <p>rvru Receive video rate used</p> <p>tvfr Transmit video frame rate</p> <p>rvfr Receive video frame rate</p> <p>vfe Video FEC errors</p> <p>tapl Transmit audio packet loss (H.323 calls only)</p> <p>tlsdp Transmit LSD protocol (H.320 calls only)</p>

Command	Syntax	Description	Example
advnetstats (continued)			rapl Receive audio packet loss (H.323 calls only) rlsdp Receive LSD protocol (H.320 calls only) taj Transmit audio jitter (h.323 calls only) tlsdr Transmit LSD rate (H.320 calls only) raj Receive audio jitter (H.323 calls only) rlsdp Receive LSD rate (H.320 calls only) tvpl Transmit video packet loss (H.323 calls only) tmlpp Transmit MLP protocol (H.320 calls only) rvpl Receive video packet loss (H.323 calls only) rmlpp Receive MLP protocol (H.320 calls only) tvj Transmit video jitter (H.323 calls only) tmlpr Transmit MLP rate (H.320 calls only) rvj Receive video jitter (H.323 calls only) rmlpr Receive MLP rate (H.320 calls only) dc Data conference rsid Remote system id

Command	Syntax	Description	Example
audiometer	<p><b>audiometer</b>  <b>&lt;micpod farin linein visualconcert</b>  <b> vcr aux off&gt;</b></p> <p>Where:</p> <ul style="list-style-type: none"> <li>• <b>micpod:</b> Measures the audio strength from microphone(s).</li> <li>• <b>farin:</b> Measures the strength of far-site audio.</li> <li>• <b>linein:</b> Measures the audio strength of any device connection to the audio line.</li> <li>• <b>visualconcert:</b> Measures the audio strength of Visual Concert VSX audio.</li> <li>• <b>vcr:</b> Measures the audio strength of VCR audio.</li> <li>• <b>aux:</b> Measures the audio strength of aux audio.</li> <li>• <b>off:</b> Turns off audiometer output.</li> </ul>	<p>Displays levels and peak of audio inputs. This command queries and prints the audio levels 10 times per second.</p> <p>User interface screen location:  <b>System &gt; Diagnostics &gt; Audio &gt; Audio Meter</b></p>	<pre>audiometer farin might return something like this:  audiometer farin level:-20 peak:-20  audiometer farin level:-19 peak:-19  audiometer farin level:-2 peak:-2  audiometer farin level:-4 peak:-4  audiometer farin level:-6 peak:-6  audiometer farin level:-8 peak:-8  audiometer farin level:1 peak:1</pre>
calldetail	<p><b>calldetail &lt;N all&gt;</b></p> <p>Where:</p> <ul style="list-style-type: none"> <li>• <b>N:</b> Displays the Nth call detail record.</li> <li>• <b>all:</b> Displays all call detail records.</li> </ul>	<p>Displays all or Nth call detail record(s).</p> <p>User interface screen location:  <b>Recent Calls</b> button</p> <p><b>Note:</b> This button is only available if enabled on the Home Screen Settings screen.</p>	<pre>calldetail all</pre>

Command	Syntax	Description	Example
callstate	<p><b>callstate &lt;register unregister get&gt;</b></p> <p>Where:</p> <ul style="list-style-type: none"> <li>• <b>register</b>: Registers the system to give notification of call activities.</li> <li>• <b>unregister</b>: Disables the register mode.</li> <li>• <b>get</b>: Returns the selected call state mode (register or unregister).</li> </ul>	Registers the API session to receive notifications about call state activities.	<pre>callstate register  returns callstate registered  Acknowledgment that the session is now registered to list call state activities.  This is an example of the callstate data that may be returned after registering.  cs: call[0] chan[0] dialstr[IP:192.16 8.1.103] state [RINGING] cs: call[0] chan[0] dialstr[IP:192.16 8.1.103] state [RINGING] cs: call[0] chan[0] dialstr[IP:192.16 8.1.103] state [CONNECTED] cs: call[0] chan[0] dialstr[IP:192.16 8.1.103] state [COMPLETE] active: call[0] speed[128] cleared: call[0] line[0] bchan[0] cause[16] dialstr[IP:192.16 8.1.103] ended: call[0]</pre>
colorbar	<p><b>colorbar &lt;on off&gt;</b></p> <p>Where:</p> <ul style="list-style-type: none"> <li>• <b>on</b>: Turns on the color bar test pattern.</li> <li>• <b>off</b>: Turns off the color bar test pattern.</li> </ul>	Turns the video diagnostics color bars on or off. User interface screen location: <b>System &gt; Diagnostics &gt; Video</b>	colorbar on

Command	Syntax	Description	Example
color-scheme	<p><b>colorscheme &lt;1 2 3 4 5&gt;</b></p> <p>Where:</p> <ul style="list-style-type: none"> <li>• <b>1, 2, 3, 4, 5:</b> Sets the system color scheme.</li> <li>• <b>get:</b> Returns the current setting.</li> </ul>	<p>Customizes the look of the VSX system with different color schemes.</p> <p>User interface screen location:  <b>System &gt; Admin Settings &gt; General Settings &gt; System Settings &gt; Appearance: Color Scheme</b></p>	<pre>colorscheme 4</pre>
display	<p><b>display &lt;call whoami&gt;</b></p> <p>Where:</p> <ul style="list-style-type: none"> <li>• <b>call:</b> Displays the following information about the current call: <ul style="list-style-type: none"> <li>□ call ID</li> <li>□ status</li> <li>□ speed</li> <li>□ the number to which this system is connected</li> </ul> </li> <li>• <b>whoami:</b> Returns information about the current system.</li> </ul>	<p>Displays either the call status or information about the current system.</p>	<p>Example 1</p> <pre>display call returns information similar to this: Call ID Status Speed Dialed Num ----- 01 CM_CALLINFO_ CONNECTED 128 192.168.1.2</pre> <p>Example 2</p> <pre>display whoami returns information similar to this: Hi, my name is: Jw_System Serial Number: xxxxx Brand: Polycom Software Version:   Release 7.0 VSX - 31Sept2004 Model: VSX7000 Network Interface: PRI_E1 MP Enabled: Yes Encryption Enabled: Yes H.264 Enabled: Yes H.323 Enabled: Yes IP Address: 192.168.1.104 GMT: Wed Sept 31 00:22:09 2004 Time In Last Call: 0:43:50 Total Time In Calls: 87:17:17 Total Calls: 819 Country Code: 1 Area Code: 512 PRI Number: 5555555</pre>

Command	Syntax	Description	Example
displayipisd- ninfo	<p><b>displayipisdninfo</b> <b>&lt;yes no both ip-only isdn-only none get&gt;</b></p> <p>Where:</p> <ul style="list-style-type: none"> <li>• <b>yes:</b> Replies with both.</li> <li>• <b>no:</b> Replies with none.</li> <li>• <b>both:</b> Enables the display of both IP and ISDN information.</li> <li>• <b>ip-only:</b> Disables the display of IP information.</li> <li>• <b>isdn-only:</b> Enables the display of ISDN information.</li> <li>• <b>none:</b> Disables the display of IP and ISDN information.</li> <li>• <b>get:</b> Returns the current setting.</li> </ul>	<p>Displays IP and ISDN information on the main user interface screen.</p> <p>User interface screen location: <b>System &gt; Admin Settings &gt; General Settings &gt; Home Screen Settings</b> (page 2): <b>IP or ISDN Information</b></p>	<pre>displayipisdninfo yes</pre>
gener- atetone	<p><b>generatetone &lt;on off&gt;</b></p> <p>Where:</p> <ul style="list-style-type: none"> <li>• <b>on:</b> Turns on the test tone.</li> <li>• <b>off:</b> Turns off the test tone.</li> </ul>	<p>Turns the test tone on or off. The tone is used to check the monitor audio cable connections or to monitor the volume level.</p> <p>User interface screen location: <b>System &gt; Diagnostics &gt; Audio &gt; Speaker Test</b></p>	<pre>generatetone on</pre>
getcallstate	<p><b>getcallstate</b></p>	<p>Gets the state of current calls. (To register the shell session to receive notifications about call state activities, see the <a href="#">callstate</a> command on page 3-45.</p> <p>User interface screen location: <b>System &gt; Diagnostics &gt; Call Statistics</b></p>	<pre>getcallstate returns something like cs: call[33] speed[512] dialstr[216.54.15 0.82] state[connected] cs: call[1] inactive cs: call[2] inactive</pre>

Command	Syntax	Description	Example
lanstat	<p><b>lanstat</b>  <b>&lt;min misc reset sec tmin total&gt;</b>  <b>lanstat min ["time"]</b>  <b>lanstat tmin ["time"]</b></p> <p>Where:</p> <ul style="list-style-type: none"> <li>• <b>sec</b>: Returns the accumulating total of LAN statistics for the current minute.</li> <li>• <b>min</b>: Returns the last 0 to 60 minutes of LAN statistics. A "time" parameter can be specified in the range {0..60}. When "time" is not specified, the last 10 minutes of statistics are returned.</li> <li>• <b>tmin</b>: Returns the last minutes of LAN statistics totals. A "time" parameter can be specified in the range {0..60}. When "time" is not specified, the last 10 minutes of statistics are returned.</li> <li>• <b>"time"</b>: Time in minutes. Must be an integer in the range {0..60.}</li> <li>• <b>total</b>: Returns cumulative LAN statistics.</li> <li>• <b>misc</b>: Returns miscellaneous LAN/VLAN statistics.</li> <li>• <b>reset</b>: Resets cumulative LAN statistics.</li> </ul>	Returns local area network statistics.	<p>Example 1</p> <pre>lanstat min 1 returns information similar to this: lanstat: LAN statistics for minute -1 lanstat: Port 0 Port 1 lanstat: rx_bytes 985 0 lanstat: tx_bytes 351 0 lanstat: rx_packets 6 0 lanstat: tx_packets 5 0 lanstat: rx_errors 0 0 lanstat: rx_unicasts 5 0 lanstat: rx_polycasts 1 0 lanstat: rx_polycasts_filt ered 0 0 lanstat: rx_resource_error 0 0 lanstat: rx_collisions 0 0 lanstat: rx_oversize_frame 0 0 lanstat: rx_runt_errors 0 0 lanstat: rx_crc_errs 0 0 lanstat: rx_align_errs 0 0 lanstat: rx_overruns 0 0 lanstat: rx_no_buffer 0 0 lanstat: rx_multiframe 0 0</pre>



Command	Syntax	Description	Example
lanstat (continued)			<pre>lanstat: tx_underruns 0 0 lanstat: tx_timeouts 0 0 lanstat: tx_restarts 0 0 lanstat: tx_ring_full 0 0 lanstat: carrier_deltas 0 0 lanstat: end <b>Example 2</b> lanstat misc  returns information something like this: Miscellaneous LAN Counters: lanstat: Free buffer count    = 2043 lanstat: Lowest free count     = 2034 lanstat: Packets discarded      = 0 lanstat: Max tx iterations     = 8 lanstat: Max rx iterations     = 4 lanstat: Max interrupt iters = 3 lanstat: Total interrupts     = 113137865 lanstat: Max interrupt delay = 441170 lanstat: Last interrupt delay = 214835 lanstat: end</pre>
nearloop	<p><b>nearloop &lt;on off&gt;</b></p> <p>Where:</p> <ul style="list-style-type: none"> <li>• <b>on:</b> Turns the Near End Loop on. It provides a complete internal test of the VSX system.</li> <li>• <b>off:</b> Disables the Near End Loop.</li> </ul>	<p>Turns the Near End Loop on or off. When it is on, you can test the encoder/decoder on the VSX system. This can help you diagnose a problem with an ISDN (H.320) video call. If you perform a near-end loop test during a call, the far site sees a loop of itself.</p> <p>User interface screen location:  <b>System &gt; Diagnostics &gt; Network: Near End Loop</b></p>	<pre>nearloop on</pre>

Command	Syntax	Description	Example
netstats	<p><b>netstats [{0..2}]</b></p> <p>Where:</p> <ul style="list-style-type: none"> <li>• <b>0..2</b>: Calls in a multipoint call, where 0 is the first endpoint connected). If no call is specified, <b>netstats</b> returns information about the near site.</li> </ul>	<p>Returns network statistics for each call.</p> <p>User interface screen location: <b>System &gt; Diagnostics &gt; Call Statistics</b> (page 2)</p>	<pre>netstats 2 returns information similar to this: call:1 txrate:128k rxrate:128k pktloss:0 %pktloss:0.00% tvp:H.263 rvp:H.263 tvf:CIF rvp:CIF tap:G.722.1 rap:G.722.1 tcp:H.323 rcp:H.323  where: txratetransmit clock rate rxratereceive clock rate pktlossnumber of packet loss/errors %pktlosspercentage of packet loss/errors tvptransmit video protocol rvpreceive video protocol tvftransmit video format rvfreceive video format taptransmit audio protocol rapreceive audio protocol tcptransmit comm protocol rcpreceive comm protocol</pre>
ping	<p><b>ping &lt;ipaddress&gt; ["count"]</b></p> <p>Where:</p> <ul style="list-style-type: none"> <li>• <b>ipaddress</b>: IP address of the device.</li> <li>• <b>"count"</b>: Optional parameter defining the number of times the device is to be pinged. The default is 1.</li> </ul>	<p>Pings the IP address of a device to check if it can be reached.</p> <p>User interface screen location: <b>System &gt; Diagnostics &gt; Network: Near End Loop</b></p>	<pre>ping 192.168.100.2</pre>

Command	Syntax	Description	Example
reboot	<b>reboot [y n]</b> <b>reboot y</b> Where: <ul style="list-style-type: none"> <li>• <b>y</b>: Reboots the system.</li> <li>• <b>n</b>: Does not reboot the system.</li> </ul>	Restarts the system. After entering <b>reboot</b> the user is prompted with "reboot, are you sure? <y,n> " User interface screen location: <b>System &gt; Diagnostics &gt; Reset System: Reset System</b>	reboot y
serialnum	<b>serialnum</b>	Returns the serial number of the VSX system. User interface screen location: <b>System &gt; System Information: Serial Number</b>	serialnum returns something like this: 0202430240x2aa
sysinfo	<b>sysinfo &lt;register unregister&gt;</b> Where: <ul style="list-style-type: none"> <li>• <b>register</b>: Registers the shell session to receive ISDN, IP, and gatekeeper status notifications.</li> <li>• <b>unregister</b>: Unregisters the shell session for ISDN, IP, and gatekeeper status notifications.</li> </ul>	Registers or unregisters the shell session to receive ISDN, IP, and gatekeeper status notifications.	sysinfo register
techsupport	<b>techsupport &lt;"phone number"&gt;</b> Where: <ul style="list-style-type: none"> <li>• <b>"phone number"</b>: Phone number at which the user of this system will be contacted. To obtain rapid assistance, include the area code with the phone number. Enclose the string in quotation marks if it includes spaces. Example: "512 555 1212"</li> </ul>	Sends your phone number to Global Management System technical support if your system is managed by the Global Management System. User interface screen location: On the remote control press the <b>Info button</b> or <b>Help button</b> and select <b>Support</b> <b>Note:</b> The Support icon is visible only when the system is registered with the Polycom Global Management System.	techsupport "1 512 555 1212"

Command	Syntax	Description	Example
testlan	<p><b>testlan &lt;arp dcuinfo dns echo ping&gt;</b>  <b>testlan arp</b>  <b>testlan dcuinfo</b>  <b>testlan dns</b>  <b>&lt;“dnsname” “ipaddress”&gt;</b>  <b>testlan ping &lt;“ipaddress”&gt;</b>  <b>[“count”]</b>  <b>testlan echo &lt;“ipaddress”&gt;</b>  <b>[“length”] [“mps”] [“reps”] [“wait”]</b>  <b>[“echoport”] [“localport”]</b></p> <p>Where:</p> <ul style="list-style-type: none"> <li>• <b>arp</b>: Returns the contents of the ARP (Address Resolution Protocol) table.</li> <li>• <b>dcuinfo</b>: Returns miscellaneous DCU information.</li> <li>• <b>dns</b>: Returns a domain name for an IP address, or an IP address for a domain name. Requires a “dnsname” or “ipaddress” parameter.</li> <li>• <b>ping</b>: Starts a ping test to determine whether the specified IP address can be reached. Requires an “ipaddress” parameter. This command is similar to the <a href="#">ping</a> command on page 3-50.</li> <li>• <b>echo</b>: Generates a series of UDP packets, and requests the system on the far end to echo the packet contents. The echo message returns the number of packets that were echoed and that were corrupted. Requires an “ipaddress” parameter.</li> <li>• <b>“dnsname”</b>: A DNS name. The <b>testlan dns</b> command returns the IP address for this DNS name.</li> <li>• <b>“ipaddress”</b>: An IP address. The <b>testlan dns</b> command returns the DNS name (if any) for this IP address.</li> <li>• <b>“count”</b>: Number of times to execute <b>testlan ping</b>.</li> </ul>	Allows you to retrieve information about the LAN, or test network connectivity.	<p><b>Example 1</b></p> <pre>testlan arp returns information similar to this: IPMAC Status 192.168.001.001 00.00.5a.00.1f.00 Resolved 192.168.001.101 00.00.03.00.16.00 Resolved</pre> <p><b>Example 2</b></p> <pre>testlan dcuinfo returns information similar to this: DCUsfor0=2044 DCUsfor36=1 DCUsfor37=1 DCUsfor44=1 DCUsfor49=2048 DCUsfor52=1 DCU IP counts: ip_xchg_count=590 , list_input_count=590 Total TX: offered=316, processed=316 DCU: Badrequestor=0, Badpointer=0, Badindex=0, total=4096</pre> <p><b>Example 3</b></p> <pre>testlan dns microsoft.com returns: testlan: microsoft.com is 207.46.197.101</pre> <p><b>Example 4</b></p> <pre>testlan dns 216.115.108.243 returns: testlan: yahoo.com is 216.115.108.243</pre>

Command	Syntax	Description	Example
testlan (continued)	<ul style="list-style-type: none"> <li>• <b>“ipaddress”</b>: Sends UDP packets to this IP address and returns an echo message with specific information when followed by any of these parameters:               <ul style="list-style-type: none"> <li>□ length</li> <li>□ mps</li> <li>□ reps</li> <li>□ wai</li> <li>□ echoport</li> <li>□ localport</li> </ul> </li> </ul> <p>For an echo message showing only the default settings, omit optional parameters.</p> <ul style="list-style-type: none"> <li>• <b>“length”</b>: Message length in bytes.</li> <li>• <b>“mps”</b>: Number of messages per second (max = 100).</li> <li>• <b>“reps”</b>: Number of times to repeat the message.</li> <li>• <b>“wait”</b>: Number of seconds to wait.</li> <li>• <b>“echoport”</b>: Port numbers to use.</li> <li>• <b>“localport”</b>: Port numbers to use.</li> </ul>		<p>Example 5</p> <pre>testlan ping 192.168.1.200 5</pre> <p>Example 6</p> <pre>testlan echo 192.168.1.159</pre> <p>returns information similar to this:</p> <pre>testlan: echo d836969f 100 10 10 100 7 1024 testlan: returned length is 100 byte testlan: sent=10, received=10, lost=0, delayed=0, corrupt=0 testlan: sent=20, received=20, lost=0, delayed=0, corrupt=0 testlan: sent=30, received=30, lost=0, delayed=0, corrupt=0 testlan: sent=40, received=40, lost=0, delayed=0, corrupt=0 testlan: sent=50, received=50, lost=0, delayed=0, corrupt=0 testlan: sent=60, received=60, lost=0, delayed=0, corrupt=0 testlan: sent=70, received=70, lost=0, delayed=0, corrupt=0</pre>

Command	Syntax	Description	Example
testlan (continued)			<pre> testlan: sent=80, received=0, lost=80, delayed=0, corrupt=0 testlan: waiting 100000us for next message testlan: sent=90, received=0, lost=90, delayed=0, corrupt=0 testlan: waiting 100000us for next message testlan: sent=100, received=0, lost=100, delayed=0, corrupt=0                     </pre>

Command	Syntax	Description	Example
xmladvnetstats	<b>xmladvnetstats [{0..2}]</b> Where: <ul style="list-style-type: none"> <li>• <b>{0..2}</b>: Returns stats for call 0, 1, or 2.</li> </ul>	Gets advanced network statistics in xml for each call.	xmladvnetstats might return something like this: <pre> &lt;ADVANCED&gt;&lt;CONFERENCE id="0"/&gt;&lt;CONNECTION id="1"&gt;&lt;FARSITENAME&gt;A&lt;/FARSITENAME&gt; &lt;FARSITENUMBER&gt;216.54.150.82&lt;/FARSITENUMBER&gt;&lt;FARSITESYSTEM&gt;Polycom/V500/Release 7.0 - 11Jun2004 04:28&lt;/FARSITESYSTEM&gt;&lt;CALLTYPE&gt;h323&lt;/CALLTYPE&gt;&lt;TRANSMIT&gt;&lt;AUDIORATE&gt;48K&lt;/AUDIORATE&gt;&lt;VIDEORATE&gt;464K&lt;/VIDEORATE&gt;&lt;VIDEORATEUSED&gt;199K&lt;/VIDEORATEUSED&gt;&lt;VIDEOFRAMERATE&gt;30.2&lt;/VIDEOFRAMERATE&gt;&lt;VIDEOPACKETLOSS&gt;0&lt;/VIDEOPACKETLOSS&gt;&lt;VIDEOJITTER&gt;3mS&lt;/VIDEOJITTER&gt;&lt;AUDIOPACKETLOSS&gt;0&lt;/AUDIOPACKETLOSS&gt;&lt;AUDIOJITTER&gt;0mS&lt;/AUDIOJITTER&gt;&lt;LSDPROTOCOL&gt;---&lt;/LSDPROTOCOL&gt;&lt;LSDRATE&gt;---&lt;/LSDRATE&gt;&lt;MLPPROTOCOL&gt;---&lt;/MLPPROTOCOL&gt;&lt;MLPRATE&gt;---&lt;/MLPRATE&gt;&gt;&lt;/TRANSMIT&gt;&lt;RECEIVE&gt;&lt;AUDIORATE&gt;48K&lt;/AUDIORATE&gt;&lt;VIDEORATE&gt;464K&lt;/VIDEORATE&gt;&lt;VIDEORATEUSED&gt;114K&lt;/VIDEORATEUSED&gt;&lt;VIDEOFRAMERATE&gt;29.8&lt;/VIDEOFRAMERATE&gt;&lt;VIDEOPACKETLOSS&gt;0&lt;/VIDEOPACKETLOSS&gt;&lt;VIDEOJITTER&gt;5           </pre>

Command	Syntax	Description	Example
xmladvnetstats (continued)			<pre>mS&lt;/VIDEOJITTER&gt;&lt;AUDIOPACKETLOSS&gt;0&lt;/AUDIOPACKETLOSS&gt;&lt;AUDIOJITTER&gt;3 mS&lt;/AUDIOJITTER&gt;&lt;LSDPROTOCOL&gt;---&lt;/LSDPROTOCOL&gt;&lt;LSDRATE&gt;---&lt;/LSDRATE&gt; &lt;MLPPROTOCOL&gt;---&lt;/MLPPROTOCOL&gt;&lt;MLPRATE&gt;---&lt;/MLPRATE&gt;&gt;&lt;/RECEIVE&gt;&lt;VIDEOFECERRORS&gt;0&lt;/VIDEOFECERRORS&gt;&lt;ENCRYPTION&gt;Disabled&lt;/ENCRYPTION&gt;&lt;/CONNECTION&gt;&lt;/ADVANCED&gt;</pre>
xmlnetstats	<p><b>xmlnetstats [{0..2}]</b></p> <p>Where:</p> <ul style="list-style-type: none"> <li>• <b>{0..2}</b>: Returns stats for call 0, 1, or 2.</li> </ul>	<p>Gets network statistics in xml for each call.</p>	<p>xmlnetstats might return something like this:</p> <pre>&lt;NETWORK&gt;&lt;CONFERENCE id="0"/&gt;&lt;CONNECTION id="1"&gt;&lt;FARSITENAME&gt;A&lt;/FARSITENAME&gt;&gt;&lt;FARSITENUMBER&gt;2 16.54.150.82&lt;/FARSITENUMBER&gt;&lt;FARSITESYSTEM&gt;Polycom/ V500/Release 7.0 - 11Jun2004 04:28&lt;/FARSITESYSTEM&gt;&lt;CALLTYPE&gt;h323&lt;/CALLTYPE&gt;&lt;TRANSMIT&gt;&lt;CALLSPEED&gt;5 12 K&lt;/CALLSPEED&gt;&lt;B2CALLSPEED&gt;---&lt;/B2CALLSPEED&gt;&lt;TOTPACKETLOSS&gt;0&lt;/TOTPACKETLOSS&gt;&lt;PERCENTPACKETLOSS&gt;0.0</pre>



Command	Syntax	Description	Example
xmlnetstats (continued)			<pre> %&lt;/PERCENTPACKETLOSS&gt;&lt;VIDEOPROTOCOL&gt;H.264&lt;/VIDEOPROTOCOL&gt;&lt;VIDEOANNEX&gt;---&lt;/VIDEOANNEX&gt;&lt;VIDEOFORMAT&gt;SIF&lt;/VIDEOFORMAT&gt;&lt;AUDIOPROTOCOL&gt;Siren14&lt;/AUDIOPROTOCOL&gt;&lt;/TRANSMIT&gt;&lt;RECEIVE&gt;&lt;CALLSPEED&gt;512K&lt;/CALLSPEED&gt;&lt;B2CALLSPEED&gt;---&lt;/B2CALLSPEED&gt;&lt;TOTPACKETLOSS&gt;0&lt;/TOTPACKETLOSS&gt;&lt;PERCENTPACKETLOSS&gt;0.0 %&lt;/PERCENTPACKETLOSS&gt;&lt;VIDEOPROTOCOL&gt;H.264&lt;/VIDEOPROTOCOL&gt;&lt;VIDEOANNEX&gt;---&lt;/VIDEOANNEX&gt;&lt;VIDEOFORMAT&gt;SIF&lt;/VIDEOFORMAT&gt;&lt;AUDIOPROTOCOL&gt;Siren14&lt;/AUDIOPROTOCOL&gt;&lt;/RECEIVE&gt;&lt;ERRORS&gt;---&lt;/ERRORS&gt;&lt;B2ERRORS&gt;---&lt;/B2ERRORS&gt;&lt;SYNC&gt;---&lt;/SYNC&gt;&lt;B2SYNC&gt;---&lt;/B2SYNC&gt;&lt;/CONNECTION&gt;&lt;/NETWORK&gt; </pre>

## IP Commands

Command	Syntax	Description	Example
defaultgateway	<p><b>defaultgateway &lt;set get&gt; ["ipaddress"]</b></p> <p>Where:</p> <ul style="list-style-type: none"> <li><b>set:</b> Sets the default gateway when followed by the "ipaddress" parameter. To erase the current setting, omit the "ipaddress" parameter.</li> <li><b>get:</b> Returns the default gateway IP address.</li> <li><b>"ipaddress":</b> IP address to use as the default gateway.</li> </ul>	<p>Sets the default gateway. This setting can only be changed if DHCP is turned off. After making a change, the user is prompted to restart the system.</p> <p>User interface screen location: <b>System &gt; Admin Settings &gt; LAN Properties (page 2): Default Gateway</b></p>	<pre>defaultgateway set 192.168.1.5</pre>
dhcp	<p><b>dhcp &lt;off client server get&gt;</b></p> <p>Where:</p> <ul style="list-style-type: none"> <li><b>off:</b> Disables DHCP.</li> <li><b>client:</b> Enables DHCP client, setting the VSX system to obtain an IP address from a server on your network.</li> <li><b>server:</b> Enables DHCP server, setting the VSX system to provide IP addresses to the other computers on your network.</li> <li><b>get:</b> Returns the selected DHCP option (off, client, or server).</li> </ul>	<p>Sets or gets DHCP options. After making a change, the user is prompted to restart the system. If the user or administrator has chosen not to allow the DHCP server option, it will not be available.</p> <p>User interface screen location: <b>System &gt; Admin Settings &gt; LAN Properties: IP Address: Obtain IP address automatically or Obtain IP address manually</b></p>	<pre>dhcp client</pre>
dns	<p><b>dns &lt;set get&gt; &lt;{1..4}&gt; ["ipaddress"]</b></p> <p>Where:</p> <ul style="list-style-type: none"> <li><b>set:</b> Sets the IP address of the specified DNS server when followed by the "ipaddress" parameter. A server identification number {1..4} is required. To erase the current setting, omit the "ipaddress" parameter.</li> <li><b>get:</b> Returns the current IP address of the specified server. A server identification number {1..4} is required.</li> <li><b>"ipaddress":</b> Returns the current setting (normal or reversed).</li> </ul>	<p>Enables you to configure DNS servers. (Up to four DNS servers can be configured.) After making a change, the user is prompted to restart the system.</p> <p>User interface screen location: <b>System &gt; Admin Settings &gt; LAN Properties (page 2): DNS Servers</b></p>	<pre>dns set 1 192.168.1.111 dns get 4</pre>

Command	Syntax	Description	Example
dynam- icbandwidth	<b>dynamicbandwidth &lt;yes no get&gt;</b> Where: <ul style="list-style-type: none"> <li><b>yes:</b> Enables the dynamic bandwidth option.</li> <li><b>no:</b> Disables the dynamic bandwidth option.</li> <li><b>get:</b> Returns the current setting (on or off).</li> </ul>	Specifies use of dynamic bandwidth allocation for Quality of Service. The VSX system's dynamic bandwidth function automatically finds the optimum line speed for a call. If you experience excessive packet loss while in a call, the dynamic bandwidth function decrements the line speed until there is no packet loss. This is supported in calls with end points that also support dynamic bandwidth.  User interface screen location: <b>System &gt; Admin Settings &gt; Network &gt; IP &gt; Quality of Service (page 2): Dynamic Bandwidth</b>	dynamicbandwidth yes
e164ext	<b>e164ext &lt;set get&gt; ["e.164name"]</b> Where: <ul style="list-style-type: none"> <li><b>set:</b> Sets the E.164 extension when followed by the "e.164name" parameter. To erase the current setting, omit "e.164name".</li> <li><b>get:</b> Returns the current setting for this option (E.164 name or empty).</li> <li><b>"e.164name":</b> A valid E.164 extension (usually a four-digit number).</li> </ul>	Specifies an H.323 (IP) extension, also known as E.164. H.323 extensions are needed for inbound calls going through a gateway. The extension number is associated with a specific LAN device.  <b>Note:</b> If you change the E.164 extension, you must restart the system.  User interface screen location: <b>System &gt; Admin Settings &gt; Network &gt; IP &gt; H.323 Settings: H.323 Extension (E.164)</b>	e164ext set returns: e164ext <empty> restart system for changes to take effect. Restart now? <y, n>
gatekeep- erip	<b>gatekeeperip &lt;set get&gt; ["ipaddress"]</b> Where: <ul style="list-style-type: none"> <li><b>set:</b> Sets the gatekeeper IP address when followed by the "ipaddress" parameter. To erase the current setting, omit "ipaddress".</li> <li><b>get:</b> Returns the current setting.</li> <li><b>"e.164name":</b> IP address of the gatekeeper.</li> </ul>	Sets the IP address of the gatekeeper.  User interface screen location: <b>System &gt; Admin Settings &gt; Network &gt; IP &gt; H.323 Settings (page 2): Gatekeeper IP Address</b>  <b>Note:</b> The Use Gatekeeper option on the same page must be set to Auto or Specify for the Gatekeeper IP Address to be available.	gatekeeperip set 192.168.1.1

Command	Syntax	Description	Example
gatewa- yareacode	<b>gatewayareacode &lt;set get&gt; ["areacode"]</b> Where: <ul style="list-style-type: none"> <li><b>set</b>: Sets the area code when followed by the "areacode" parameter. To erase the current setting, omit "areacode".</li> <li><b>get</b>: Returns the area code setting for the gateway.</li> <li><b>"areacode"</b>: Numeric string specifying the area code.</li> </ul>	Sets the gateway area code. User interface screen location: <b>System &gt; Admin Settings &gt; Network &gt; IP &gt; H.323 Settings</b> (page 4): <b>Area Code</b>	gatewayareacode set 512 gateway area code set erases the current setting.
gateway- countrycode	<b>gatewaycountrycode &lt;set get&gt; ["number"]</b> Where: <ul style="list-style-type: none"> <li><b>set</b>: Sets the gateway country code when followed by the "number" parameter. To erase the current setting, omit "number".</li> <li><b>get</b>: Returns the current setting.</li> <li><b>"number"</b>: Numeric string specifying the gateway country code.</li> </ul>	Sets the gateway country code. User interface screen location: <b>System &gt; Admin Settings &gt; Network &gt; IP &gt; H.323 Settings</b> (page 4): <b>Country Code</b>	gatewaycountry- code set 1
gatewayext	<b>gatewayext &lt;set get&gt; ["extension"]</b> Where: <ul style="list-style-type: none"> <li><b>set</b>: Sets the gateway extension number when followed by the "extension" parameter. To erase the current setting, omit "extension".</li> <li><b>get</b>: Returns the current setting.</li> <li><b>"number"</b>: Numeric string specifying the gateway extension.</li> </ul>	Sets the gateway extension number. After making a change, you must restart the system. User interface screen location: <b>System &gt; Admin Settings &gt; Network &gt; IP &gt; H.323 Settings</b> (page 4): <b>H.323 Extension (E.164)</b>	gatewayext set 59715
gate- waynumber	<b>gatewaynumber &lt;set get&gt; ["number"]</b> Where: <ul style="list-style-type: none"> <li><b>set</b>: Sets the gateway number when followed by the "number" parameter. To erase the current setting, omit "number".</li> <li><b>get</b>: Returns the current setting.</li> <li><b>"number"</b>: Numeric string specifying the gateway number.</li> </ul>	Sets the gateway number. User interface screen location: <b>System &gt; Admin Settings &gt; Network &gt; IP &gt; H.323 Settings</b> (page 4): <b>Number</b>	gatewaynumber set 5551212

Command	Syntax	Description	Example
gatewaynumbertype	<p><b>gatewaynumbertype &lt;did number+extension get&gt;</b></p> <p>Where:</p> <ul style="list-style-type: none"> <li>• <b>did</b>: Indicates that the gateway number is a direct inward dial number; it has no extension.</li> <li>• <b>number+extension</b>: Indicates that the gateway number includes an extension.  This option allows the call to go through directly (it dials the Gateway Number + ## + Extension as one number).</li> <li>• <b>get</b>: Returns the current setting (did or number+extension).</li> </ul>	<p>Specifies the Gateway Number Type, which can be either Direct Inward Dial (DID) or Number+Extension.</p> <p>User interface screen location: <b>System &gt; Admin Settings &gt; Network &gt; IP &gt; H.323 Settings</b> (page 4): <b>Gateway Number Type</b></p>	<pre>gatewaynumbertype number+extension</pre>
gatewayprefix	<p><b>gatewayprefix &lt;set get&gt; &lt;“valid speed”&gt; [“value”]</b></p> <p>Where:</p> <ul style="list-style-type: none"> <li>• <b>set</b>: Sets the gateway prefix when followed by the “value” parameter.  To erase the current setting, omit “value”.</li> <li>• <b>get</b>: When followed by the “valid speed” parameter, returns the current value for this speed.</li> <li>• <b>“valid speed”</b>: Valid speeds are: 56, 64, 2x56, 112, 2x64, 128, 168, 192, 224, 256, 280, 320, 336, 384, 392, 7x64, 8x56, 504, 512, 560, 576, 616, 640, 672, 704, 728, 768, 784, 832, 840, 16x56, 14x64, 952, 960, 1008, 1024, 1064, 1088, 1120, 1152, 1176, 1216, 1232, 1280, 1288, 24x56, 21x64, 1400, 1408, 1456, 1472, 1512, 1536, 1568, 1600, 1624, 1664, 1680, 1728, 1736, 32x56, 28x64, 1848, 1856, 1904, and 1920 kbps.</li> <li>• <b>“value”</b>: Prefix (code) used for a particular call speed. Consult your gateway instruction manual to determine which codes are appropriate.</li> </ul>	<p>Sets the gateway prefixes for the corresponding speeds. Some gateways require a number to be prepended (prefix) to the gateway number. The prefix identifies which gateway is used to dial a call at a particular data rate.</p> <p>User interface screen location: <b>System &gt; Admin Settings &gt; Network &gt; IP &gt; H.323 Settings</b> (page 5): <b>Prefix</b></p>	<pre>gatewayprefix set 168 90</pre>

Command	Syntax	Description	Example
gateway-setup	<b>gatewaysetup</b>	Lists all available speeds and values at once. User interface screen location: <b>System &gt; Admin Settings &gt; Network &gt; IP &gt; H.323 Settings</b> (page 5): <b>Prefix and Suffix</b>	gateway setup returns: 56 #12 #13 64 #14 #16 2x56 #222 #333 112 #444 #555 2x64 128 168 192 224 256 etc...
gatewaysuffix	<b>gatewaysuffix &lt;set get&gt; &lt;“valid speed”&gt; [“value”]</b>  Where: <ul style="list-style-type: none"> <li>• <b>set</b>: Sets the gateway suffix when followed by the “value” parameter. To erase the current setting, omit “value”.</li> <li>• <b>get</b>: Returns the current value for this speed.</li> <li>• <b>“valid speed”</b>: Valid speeds are: 56, 64, 2x56, 112, 2x64, 128, 168, 192, 224, 256, 280, 320, 336, 384, 392, 7x64, 8x56, 504, 512, 560, 576, 616, 640, 672, 704, 728, 768, 784, 832, 840, 16x56, 14x64, 952, 960, 1008, 1024, 1064, 1088, 1120, 1152, 1176, 1216, 1232, 1280, 1288, 24x56, 21x64, 1400, 1408, 1456, 1472, 1512, 1536, 1568, 1600, 1624, 1664, 1680, 1728, 1736, 32x56, 28x64, 1848, 1856, 1904, and 1920 kbps.</li> <li>• <b>“value”</b>: Suffix (code) used for a particular call speed. Consult your gateway instruction manual to determine which codes are appropriate. Use quotation marks around a compound name or strings that contain spaces. For example: “united states” or “111 222 333”.</li> </ul>	Sets the gateway suffix. Some gateways require a number to be appended (suffix) to the gateway number. The suffix identifies which gateway is used to dial a call at a particular data rate.  User interface screen location: <b>System &gt; Admin Settings &gt; Network &gt; IP &gt; H.323 Settings</b> (page 5): <b>Suffix</b>	gatewaysuffix set 192 11

Command	Syntax	Description	Example
h323name	<p><b>h323name &lt;set get&gt; ["H.323 name"]</b></p> <p>Where:</p> <ul style="list-style-type: none"> <li>• <b>set</b>: Sets the H.323 name when followed by the "H.323name" parameter.</li> <li>To erase the current setting, omit "H.323name".</li> <li>• <b>get</b>: Returns the current setting.</li> <li>• <b>"H.323name"</b>: Character string specifying the H.323 name. Use quotation marks around strings that contain spaces. For example: "Pacific Room VSX".</li> </ul>	<p>Sets the H.323 name.</p> <p>User interface screen location:  <b>System &gt; Admin Settings &gt; Network &gt; IP &gt; H.323 Settings: H.323 Name</b></p>	<pre>h323name set "Pacific Room VSX"</pre>
hostname	<p><b>hostname &lt;set get&gt; ["hostname"]</b></p> <p>Where:</p> <ul style="list-style-type: none"> <li>• <b>set</b>: Sets the VSX system's LAN host name when followed by the "hostname" parameter.</li> <li>If "hostname" is omitted, the system automatically sets it to Admin.</li> <li>• <b>get</b>: Returns the current setting.</li> <li>• <b>"hostname"</b>: Character string specifying the LAN host name of the VSX system. The LAN host name follows these format rules: <ul style="list-style-type: none"> <li>❑ Starts with a letter (A-a to Z-z). It is not case sensitive.</li> <li>❑ Ends with a letter (A-a to Z-z) or a number (0 to 9).</li> <li>❑ May include letters, numbers, and a hyphen.</li> <li>❑ May not be longer than 63 characters.</li> </ul> </li> </ul> <p><b>Note:</b> The LAN host name is initialized during the out-of-box setup sequence. The LAN host name is the same as the system name, if the system name conforms to the rules above. If the system name does not conform to these rules, the invalid characters are removed from the system name. If the resulting string is empty, the default LAN host name is Admin.</p>	<p>Sets the LAN host name, which is assigned to the VSX system for TCP/IP configuration and can be used in place of an IP address when dialing IP calls. A LAN host name is required; it cannot be deleted or left blank. After making a change, the user is prompted to restart the system.</p> <p>User interface screen location:  <b>System &gt; Admin Settings &gt; LAN Properties: Host Name</b></p>	<pre>hostname set returns: hostname ADMIN</pre>

Command	Syntax	Description	Example
ipaddress	<b>ipaddress &lt;set get&gt; ["ipaddress"]</b> Where: <ul style="list-style-type: none"> <li>• <b>set</b>: Sets the LAN IP address to the "ipaddress" parameter. This setting can only be changed when DHCP is off.</li> <li>• <b>get</b>: Returns the current setting for this option.</li> <li>• <b>"ipaddress"</b>: IP address of the VSX system.</li> </ul>	Sets the LAN IP address of the VSX system. Use this command when you need to allocate a static IP address to your system. After making a change, the user is prompted to restart the system.  User interface screen location: <b>System &gt; Admin Settings &gt; LAN Properties: Use the Following IP Address</b>	<pre>ipaddress set 192.168.1.111</pre>
ipprecaudio, ipprecfec, ipprecvideo	<b>ipprecaudio &lt;set get&gt;</b> <b>ipprecaudio set &lt;{0..5}&gt;</b> <b>ipprecfec &lt;set get&gt;</b> <b>ipprecfec set &lt;{0..5}&gt;</b> <b>ipprecvideo &lt;set get&gt;</b> <b>ipprecvideo set &lt;{0..5}&gt;</b> Where: <ul style="list-style-type: none"> <li>• <b>set</b>: Sets the IP precedence. A priority level is required. This must be an integer in the range {0..5}.</li> <li>• <b>get</b>: Returns the current setting.</li> </ul>	Enable the IP Precedence option and specify a priority level (Type of Service Value) for audio, far-end camera control (FECC), and video, respectively. The value for each can be between 0 and 5.  User interface screen location: <b>System &gt; Admin Settings &gt; Network &gt; IP &gt; Quality of Service: Type of Service: IP Precedence and Type of Service Value</b>	<pre>ipprecaudio set 5</pre>
ipstat	<b>ipstat</b>	Returns the LAN host name, WINS resolution, DHCP, IP address, DNS servers 1-4, default gateway, subnet mask, and WINS server.  User interface screen location: <b>System &gt; Admin Settings &gt; LAN Properties (both pages)</b>	<pre>ipstat returns information similar to this: hostname MyVSX winsresolution no dhcp client ipaddress 192.168.1.111 dnsserver 192.168.1.2 dnsserver1 192.168.1.3 dnsserver2 192.168.1.4 dnsserver3 0.0.0.0 defaultgateway 192.168.1.5 subnetmask 255.255.255.0 winsserver 192.168.1.6 lanport auto</pre>



Command	Syntax	Description	Example
lanport	<p><b>lanport</b>  <b>&lt;auto autohdx autofdx "rate" get&gt;</b></p> <p>Where:</p> <ul style="list-style-type: none"> <li>• <b>auto</b>: Automatically negotiates the LAN speed and duplex mode.</li> <li>• <b>autohdx</b>: Automatically negotiates the LAN speed but specifies half-duplex mode.</li> <li>• <b>autofdx</b>: Automatically negotiates the LAN speed but specifies full-duplex mode.</li> <li>• <b>"rate"</b>: Lan speed and duplex mode: <ul style="list-style-type: none"> <li>□ 10: 10 Mbps auto duplex</li> <li>□ 10hdx: 10 Mbps half duplex</li> <li>□ 10fdx: 10 Mbps full duplex</li> <li>□ 100: 100 Mbps auto duplex</li> <li>□ 100hdx: 100 Mbps half duplex</li> <li>□ 100fdx: 100 Mbps full duplex</li> </ul> </li> <li>• <b>get</b>: Returns the current setting.</li> </ul>	<p>Sets the LAN port settings of the VSX system. After making a change, you must restart the system.</p> <p>User interface screen location:  <b>System &gt; Admin Settings &gt; LAN Properties</b> (page 2): <b>LAN Speed and Duplex Mode</b></p>	lanport auto
numdigits-did	<p><b>numdigitsdid &lt;{0..99} get&gt;</b></p> <p>Where:</p> <ul style="list-style-type: none"> <li>• <b>{0..99}</b>: Specifies the number of digits in DID numbers.</li> <li>• <b>get</b>: Returns the current setting.</li> </ul>	<p>Sets the number of digits in the DID Gateway number (E.164 dialing). The number of digits in the DID is that portion of the full DID that the Gateway will be given from the ISDN service provider as the Called Party Line Identifier. This, in turn, will be passed to the Gatekeeper for address resolution.</p> <p>User interface screen location:  <b>System &gt; Admin Settings &gt; Network &gt; IP &gt; H.323 Settings</b> (page 4): <b>Number of Digits in DID Number</b></p> <p><b>Note:</b> For this option to be available, the <b>Gateway Number Type</b> on the same page must be set to Direct Inward Dial.</p>	numdigitsdid 7

Command	Syntax	Description	Example
numdigit-sext	<p><b>numdigitsext &lt;{0..99} get&gt;</b></p> <p>Where:</p> <ul style="list-style-type: none"> <li><b>{0..99}</b>: The number of digits in the gateway number if <b>gatewaynumbertype</b> is set to <b>number+extension</b>.</li> <li><b>get</b>: Returns the current setting.</li> </ul>	<p>Sets the number of digits in the Number+Extension Gateway number (E.164 dialing). The number of digits in that number is that portion of the full Number+Extension number that the Gateway will be given from the ISDN service provider as the Called Party Line Identifier. This, in turn, will be passed to the Gatekeeper for address resolution.</p> <p>User interface screen location:  <b>System &gt; Admin Settings &gt; Network &gt; IP &gt; H.323 Settings</b> (page 4): <b>Number of Digits in Extension</b></p>	numdigitsext 10
subnetmask	<p><b>subnetmask &lt;set get&gt; ["ipaddress"]</b>  <b>subnetmask set ["ipaddress"]</b></p> <p>Where:</p> <ul style="list-style-type: none"> <li><b>set</b>: Sets the subnet mask of the VSX system when followed by the "ipaddress" parameter. To erase the current setting, omit "ipaddress".</li> <li><b>get</b>: Returns the current subnet mask.</li> <li><b>"ipaddress"</b>: Subnet mask of the VSX system.</li> </ul>	<p>Sets the subnet mask of the VSX system. After making a change, the user is prompted to restart the system.</p> <p>User interface screen location:  <b>System &gt; Admin Settings &gt; LAN Properties</b> (page 2): <b>Subnet Mask</b></p>	subnetmask set 255.255.255.0
tcpports	<p><b>tcpports &lt;set get&gt; [{1024..49150}]</b>  <b>tcpports set [{1024..49150}]</b></p> <p>Where:</p> <ul style="list-style-type: none"> <li><b>set</b>: Sets the TCP ports when followed by a value from the range {1024..49150}. To erase the current setting, omit the value.</li> <li><b>get</b>: Returns the current TCP port setting.</li> </ul>	<p>Sets the TCP ports on the VSX system.</p> <p>User interface screen location:  <b>System &gt; Admin Settings &gt; Network &gt; IP &gt; Firewall: Fixed Ports &gt; TCP Ports</b></p> <p><b>Note:</b> The Fixed Ports option on the same page must be selected for the TCP Ports option to be available.</p>	tcpports set 3233

Command	Syntax	Description	Example
typeofservice	<p><b>typeofservice</b> <b>&lt;ipprecedence diffserv get&gt;</b></p> <p>Where:</p> <ul style="list-style-type: none"> <li>• <b>ipprecedence</b>: Selects IP precedence service. See the commands <a href="#">ipprecaudio</a>, <a href="#">ipprecfecc</a>, and <a href="#">ipprecvideo</a> on page 3-64.</li> <li>• <b>diffserv</b>: Selects DiffServ service. See the commands <a href="#">diffservaudio</a>, <a href="#">diffservfecc</a>, and <a href="#">diffservvideo</a> on page 3-26.</li> <li>• <b>get</b>: Returns the current setting (ipprecedence or diffserv).</li> </ul>	Selects the type of service for Quality of Service.	typeofservice diffserv
udpports	<p><b>udpports &lt;set get&gt;</b> <b>udpport set [{1024..49150}]</b></p> <p>Where:</p> <ul style="list-style-type: none"> <li>• <b>set</b>: Sets the UDP ports when followed by a value from the range {1024..49150}. To erase the current setting, omit the value.</li> <li>• <b>get</b>: Returns the current UDP port setting.</li> </ul>	<p>Sets the UDP ports on the VSX system.</p> <p>User interface screen location: <b>System &gt; Admin Settings &gt; Network &gt; IP &gt; Firewall: Fixed Ports:UDP Ports</b></p> <p><b>Note:</b> The UDP Ports option on the same page must be selected for the TCP Ports option to be available.</p>	udpports set 3230
usefixedports	<p><b>usefixedports &lt;yes no get&gt;</b></p> <p>Where:</p> <ul style="list-style-type: none"> <li>• <b>yes</b>: Enables the use of Fixed Ports.</li> <li>• <b>no</b>: Disables the use of Fixed Ports.</li> <li>• <b>get</b>: Returns the current setting (yes or no).</li> </ul>	<p>Selects the Fixed Ports option.</p> <p>User interface screen location: <b>System &gt; Admin Settings &gt; Network &gt; IP &gt; Firewall: Fixed Ports</b></p>	usefixedports yes
usegatekeeper	<p><b>usegatekeeper</b> <b>&lt;off specify auto get&gt;</b></p> <p>Where:</p> <ul style="list-style-type: none"> <li>• <b>off</b>: Select this option if no gatekeeper is required or if you make IP-to-IP LAN calls.</li> <li>• <b>specify</b>: Specifies a gatekeeper. If this option is selected, you must enter the gatekeeper IP address or name using the <b>gatekeeperip</b> command on <a href="#">page 3-59</a>.</li> <li>• <b>auto</b>: Sets the system to automatically find an available gatekeeper.</li> <li>• <b>get</b>: Returns the current setting (off, specify, or auto).</li> </ul> <p><b>Note:</b> A gatekeeper is not required to make IP-to-IP LAN calls. In these situations, select the off option.</p>	<p>Selects the gatekeeper mode (off, specify, or auto). After making a change, the user is prompted to restart the system.</p> <p>User interface screen location: <b>System &gt; Admin Settings &gt; Network &gt; IP &gt; H.323 Settings (page 2): Use Gatekeeper</b></p>	usegatekeeper specify gatekeeperip set 255.255.255.0

Command	Syntax	Description	Example
wanipaddress	<p><b>wanipaddress &lt;set get&gt;</b>  <b>wanipaddress set ["ipaddress"]</b></p> <p>Where:</p> <ul style="list-style-type: none"> <li>• <b>set:</b> Sets the WAN IP address when followed by the "ipaddress" parameter. To erase the current setting, omit the "ipaddress" parameter.</li> <li>• <b>get:</b> Returns the WAN IP address.</li> <li>• <b>"ipaddress":</b> WAN IP address.</li> </ul>	<p>Sets the WAN IP address.</p> <p>User interface screen location:  <b>System &gt; Admin Settings &gt; Network &gt; IP &gt; Firewall: NAT Public (WAN) Address</b></p> <p><b>Note:</b> The NAT Configuration option on the same page must be set to Auto, Manual, or UPnP for this option to be available.</p>	<pre>wanipaddress set 192.168.1.122</pre>
winsresolution	<p><b>winsresolution &lt;yes no get&gt;</b></p> <p>Where:</p> <ul style="list-style-type: none"> <li>• <b>yes:</b> Enables WINS resolution.</li> <li>• <b>no:</b> Disables WINS resolution.</li> <li>• <b>get:</b> Returns the current setting (yes or no).</li> </ul>	<p>Sets WINS resolution. After a change is made, the system prompts the user for restart.</p> <p>User interface screen location:  <b>System &gt; Admin Settings &gt; LAN Properties (page 2): WINS Resolution</b></p>	<pre>winsresolution no</pre>

## ISDN Commands

Command	Syntax	Description	Example
areacode	<b>areacode &lt;set get&gt;</b> <b>areacode set ["code"]</b> Where: <ul style="list-style-type: none"> <li>• <b>set</b>: Sets the ISDN BRI area code when followed by the area code parameter. If you want to erase the current setting, omit area code.</li> <li>• <b>get</b>: Returns the area code information.</li> <li>• <b>"code"</b>: Area code to use for all BRI lines.</li> </ul>	Sets the area code for all ISDN BRI lines. This code is associated with the area where the VSX system is used. User interface screen location: <b>System &gt; Admin Settings &gt; Network &gt; ISDN</b> (page 2): <b>Area Code</b> (for Line 1, Line 2, Line 3, and Line 4)	<pre>areacode get returns information similar to this: areacode 212</pre>
bri1enable, bri2enable, bri3enable, bri4enable	<b>bri1enable &lt;yes no get&gt;</b> <b>bri2enable &lt;yes no get&gt;</b> <b>bri3enable &lt;yes no get&gt;</b> <b>bri4enable &lt;yes no get&gt;</b> Where: <ul style="list-style-type: none"> <li>• <b>yes</b>: Enables the BRI line.</li> <li>• <b>no</b>: Disables the BRI line.</li> <li>• <b>get</b>: Returns the status of the BRI line—<b>yes</b> if enabled, <b>no</b> if disabled.</li> </ul>	Enables or disables the ISDN BRI line specified in the command name. User interface screen location: <b>System &gt; Admin Settings &gt; Network &gt; ISDN</b> (page 2): <b>Enable</b> (for each line)	<pre>brilenable yes</pre>
briallenable	<b>briallenable &lt;yes no get&gt;</b> Where: <ul style="list-style-type: none"> <li>• <b>yes</b>: Enables all BRI lines.</li> <li>• <b>no</b>: Disables all BRI lines.</li> <li>• <b>get</b>: Returns the status of all BRI lines—<b>yes</b> if enabled, <b>no</b> if disabled.</li> </ul>	Enables or disables all ISDN BRI lines. User interface screen location: <b>System &gt; Admin Settings &gt; Network &gt; ISDN</b> (page 2): <b>Enable</b> (for Line 1, Line 2, Line 3, and Line 4)	<pre>briallenable yes</pre>
cts	<b>cts &lt;normal inverted get&gt;</b> Where: <ul style="list-style-type: none"> <li>• <b>normal</b>: Sets the signal to normal (high voltage is logic 1).</li> <li>• <b>inverted</b>: Sets the signal to inverted (low voltage is logic 1).</li> <li>• <b>get</b>: Returns the current setting (normal or inverted).</li> </ul>	Lets you configure the cts serial interface control signal (clear to send). The default setting for this signal is "normal". User interface screen location: <b>System &gt; Admin Settings &gt; Network &gt; IP &gt; H.323 Settings &gt; V.35/RS-449/RS-530</b> (page 3): <b>CTS</b>	<pre>cts normal</pre>
dcd	<b>dcd &lt;normal inverted get&gt;</b> Where: <ul style="list-style-type: none"> <li>• <b>normal</b>: Sets the signal to normal (high voltage is logic 1).</li> <li>• <b>inverted</b>: Sets the signal to inverted (low voltage is logic 1).</li> <li>• <b>get</b>: Returns the current setting (normal or inverted).</li> </ul>	Lets you configure the dcd serial interface control signal (data carrier detect). The default setting for this signal is "normal". User interface screen location: <b>System &gt; Admin Settings &gt; Network &gt; V.35/RS-449/RS-530</b> (page 3): <b>DCD</b>	<pre>dcd inverted</pre>

Command	Syntax	Description	Example
dcdfilter	<b>dcdfilter &lt;on off get&gt;</b> Where: <ul style="list-style-type: none"> <li><b>on:</b> Enables the dcd filter.</li> <li><b>off:</b> Disables the dcd filter.</li> <li><b>get:</b> Returns the current setting (on or off).</li> </ul>	Lets you configure the filter of the dcd serial interface control signal (data carrier detect). When this filter is enabled, dcd drops for 60 seconds before changing the call state. The default setting for this signal is "off".	dcdfilter on
dsr	<b>dsr &lt;normal inverted get&gt;</b> Where: <ul style="list-style-type: none"> <li><b>normal:</b> Sets the signal to normal (high voltage is logic 1).</li> <li><b>inverted:</b> Sets the signal to inverted (low voltage is logic 1).</li> <li><b>get:</b> Returns the current setting (normal or inverted).</li> </ul>	Lets you configure the dsr serial interface control signal (data set ready). The default setting for this signal is "normal". User interface screen location: <b>System &gt; Admin Settings &gt; Network &gt; V.35/RS-449/RS-530 (page 3): DSR</b>	dsr get
dsranswer	<b>dsranswer &lt;on off get&gt;</b> Where: <ul style="list-style-type: none"> <li><b>on:</b> Turns on the option.</li> <li><b>off:</b> Turns off the option.</li> <li><b>get:</b> Returns the current status (on or off).</li> </ul>	Sets or gets the dsr serial interface control signal to indicate an incoming call. User interface screen location: <b>System &gt; Admin Settings &gt; Network &gt; V.35/RS-449/RS-530 (page 3): Answer on DSR</b>	dsranswer on
dtr	<b>dtr &lt;normal inverted on get&gt;</b> Where: <ul style="list-style-type: none"> <li><b>normal:</b> Sets the signal to normal (high voltage is logic 1).</li> <li><b>inverted:</b> Sets the signal to inverted (low voltage is logic 1).</li> <li><b>on:</b> Sets constant high voltage. If this option is selected, inverted is not an option.</li> <li><b>get:</b> Returns the current setting (normal or inverted).</li> </ul>	Sets or gets the dtr serial interface control signal (data terminal ready) to normal or inverted. The default setting for the signal is "normal". User interface screen location: <b>System &gt; Admin Settings &gt; Network &gt; V.35/RS-449/RS-530 (page 3): DTR</b>	dtr get
isdncountry-code	<b>isdncountrycode &lt;set get&gt;</b> <b>isdncountrycode set ["code"]</b> Where: <ul style="list-style-type: none"> <li><b>set:</b> Sets the ISDN country code when followed by the "code" parameter. To erase the current setting, omit "code."</li> <li><b>get:</b> Returns the country code information.</li> <li><b>"code":</b> The ISDN country code.</li> </ul>	Sets the ISDN country code associated with the country where the VSX system is used. The system is generally able to automatically determine the country code based on the country you selected during initial system setup. User interface screen location: <b>System &gt; Admin Settings &gt; Network &gt; ISDN (page 2): Country Code</b>	isdncountrycode set 1

Command	Syntax	Description	Example
isdndialing-prefix	<b>isdndialingprefix &lt;set get&gt;</b> <b>isdndialingprefix set ["prefix"]</b> Where: <ul style="list-style-type: none"> <li>• <b>set:</b> Sets the ISDN prefix when followed by the "prefix" parameter. To erase the current setting, omit "prefix".</li> <li>• <b>get:</b> Returns the dialing prefix.</li> <li>• <b>"prefix":</b> The digit(s) that must be dialed to reach an outside line.</li> </ul>	Sets the ISDN dialing prefix used to access an outside line if the VSX system is behind a PBX. User interface screen location: <b>System &gt; Admin Settings &gt; Network &gt; ISDN: Outside Line Dialing Prefix</b>	<pre>isdndialingprefix set 9</pre>
isdnum	<b>isdnum &lt;set get&gt;&lt;"bchannel"&gt;</b> <b>isdnum set &lt;"bchannel"&gt;["number"]</b> Where: <ul style="list-style-type: none"> <li>• <b>set:</b> Sets the ISDN number for a B channel line when followed by the "number" parameter. If you want to erase the current setting, omit "number".</li> <li>• <b>get:</b> Returns the current ISDN number associated with the specified B channel.</li> <li>• <b>"bchannel":</b> The line and B channel. Valid values are:                1b1BRI line 1, B channel 1                1b2BRI line 1, B channel 2                2b1BRI line 2, B channel 1                2b2BRI line 2, B channel 2                3b1BRI line 3, B channel 1                3b2BRI line 3, B channel 2                4b1BRI line 4, B channel 1                4b2BRI line 4, B channel 2</li> <li>• <b>"number":</b> The ISDN number(s) provided by your network service provider for the specified B channel.</li> </ul>	Sets the ISDN video number or numbers assigned to the VSX system. User interface screen location: <b>System &gt; Admin Settings &gt; Network &gt; ISDN (page 2): Directory Numbers</b>	<pre>isdnum set 1b1 5125551212</pre>
isdswitch	<b>isdswitch &lt;"protocol" get&gt;</b> Where: <ul style="list-style-type: none"> <li>• <b>"protocol":</b> Specifies the ISDN switch protocol to use. Valid values are:                pt-to-pt_at&amp;t_5_ess                multipoint_at&amp;t_5_ess                ni-1                nortel_dms-100                standard_etsi_euro-isdn                ts-031                ntt_ins64</li> <li>• <b>get:</b> Returns the current switch protocol.</li> </ul>	Sets the ISDN switch. If more than one switch protocol is supported, you must find out from your telephone service provider which protocol to select. If you change the country settings, a new set of ISDN switch protocols is loaded. User interface screen location: <b>System &gt; Admin Settings &gt; Network &gt; ISDN: ISDN Switch Protocols</b>	<pre>isdswitch nortel_dms-100</pre>

Command	Syntax	Description	Example
priareacode	<p><b>priareacode &lt;set get&gt; ["area code"]</b></p> <p>Where:</p> <ul style="list-style-type: none"> <li>• <b>set</b>: Sets the PRI area code when followed by the "area code" parameter. To erase the current setting, omit "area code".</li> <li>• <b>get</b>: Returns the current setting.</li> <li>• <b>"area code"</b>: Numeric string specifying the area code.</li> </ul>	<p>Sets or gets the PRI area code.</p> <p>User interface screen location:  <b>System &gt; Admin Settings &gt; Network &gt; ISDN: Area Code</b></p> <p><b>Note:</b> This screen is only accessible if you have a PRI network interface connected to your system.</p>	<pre>priareacode set 512</pre>
pricallbycall	<p><b>pricallbycall &lt;set get&gt; [{0..31}]</b></p> <p>Where:</p> <ul style="list-style-type: none"> <li>• <b>set</b>: Sets PRI call-by-call when followed by a value from {0..31}. To erase the current setting, omit the value.</li> <li>• <b>get</b>: Returns the current setting.</li> <li>• <b>{0..31}</b>: Range of call-by-call values.</li> </ul>	<p>Sets or gets the PRI area code. Call-by-call is a number from 1 to 31, which is optionally sent to an upstream telephone company switch, if required. For example, specify a value of 6 for a T1 PRI network interface module that is directly connected to an ATT 5ESS switch, which is provisioned with Accu-net. You must consult with the telephone company service provider to determine whether a call-by-call value is required for a particular PRI line. For most cases, the default value of 0 is correct. Always use the value 0 when connected to a PBX. A non-zero value should not be required in Europe. Values greater than 31 are reserved for internal use and must not be used.</p> <p>User interface screen location:  <b>System &gt; Admin Settings &gt; Network &gt; ISDN (page 3): Call-by-Call</b></p> <p><b>Note:</b> This screen is only accessible if you have a PRI network interface connected to your system.</p>	<pre>pricallbycall set 1</pre>



Command	Syntax	Description	Example
prichannel	<p><b>prichannel &lt;set get&gt;</b>  <b>&lt;all {1..23 1..30}&gt; &lt;on off&gt;</b>  <b>prichannel set all &lt;on off&gt;</b>  <b>prichannel set &lt;{1..23}&gt; &lt;on off&gt;</b>  <b>prichannel set &lt;{1..30}&gt; &lt;on off&gt;</b>  <b>prichannel get all &lt;on off&gt;</b>  <b>prichannel get &lt;{1..23}&gt; &lt;on off&gt;</b>  <b>prichannel get &lt;{1..30}&gt; &lt;on off&gt;</b></p> <p>Where:</p> <ul style="list-style-type: none"> <li>• <b>set:</b> Sets the PRI channels to be active when followed by a parameter from &lt;all {1..23 1..30}&gt; and from &lt;on off&gt;. To erase the current settings, omit the parameters.</li> <li>• <b>get:</b> Returns the current setting (on or off). Requires a parameter from &lt;all {1..23 1..30}&gt;.</li> <li>• <b>all:</b> Selects all PRI channels.</li> <li>• <b>{1..23 1..30}:</b> Range of available PRI channels. For PRI T1, the range is 1..23. For PRI E1, the range is 1..30.</li> <li>• <b>on:</b> Activates the selected PRI channels.</li> <li>• <b>off:</b> Disables the selected PRI channels.</li> </ul>	<p>Selects the PRI channels that will be active for the PRI line. See “Important PRI Channel Information” on page 3-73 for more information.</p> <p>User interface screen location:  <b>System &gt; Admin Settings &gt; Network &gt; ISDN</b> (page 5):  <b>Active Channels</b></p> <p><b>Note:</b> This screen is only accessible if you have a PRI network interface connected to your system.</p>	<p>Example 1  prichannel set all  on  Example 2  prichannel set  Example 3  prichannel get 3</p>

### Important PRI Channel Information

**Outgoing Call.** For an outgoing call, the VSX system uses the first active and available channel starting with the lowest number from the channel range (1-23 for a PRI T1 and 1-30 for a PRI E1). If an additional channel is needed, the system chooses the next incremental number. For example, if channels 1 through 7 are inactive, but 8 is active and available, then 8 is the first channel that can be used by the VSX system to place an outgoing call. If an additional channel is needed, the system will use the next available active channel in the range (which could be 9, and so on).

**Incoming Calls.** For incoming calls, the VSX system may use the highest numbered channel in the range and, if needed, proceed to the next channel number in descending order, depending on the type of third-party equipment attached to the system. For example, an incoming call arrives on channel 23, then 22, 21, and so on.

**Dedicated full PRI T1 or E1 Line.** All channels should be active for a full T1 or E1 line dedicated to your VSX system.

**Fractional PRI T1 or E1.** Channel selection should be handled by your PRI network administrator.

**PRI E1 Channel Information.** The PRI Status screen (for E1) shows 30 channels. However, E1 trunk lines have 32 timeslots, numbered 0 - 31. Timeslot 0 is used for framing, and timeslot 16 is used for call signaling (the D channel). The remaining 30 timeslots are used as bearer (data) channels. In call signaling between our equipment and the switch, these channels are numbered 1-15, 17-31. But the PRI Status screen numbers these channels contiguously in the range 1-30. Therefore, on the PRI Status screen, channels 1-15 control the status of timeslots 1-15, and channels 16-30 control the status of timeslots 17-31.

Command	Syntax	Description	Example
pricsu	<b>pricsu &lt;internal external get&gt;</b> Where: <ul style="list-style-type: none"> <li>• <b>internal:</b> Sets the internal CSU mode. This is the default.</li> <li>• <b>external:</b> Sets the external CSU mode. When selected, you must specify the PRI line buildout. (See the <a href="#">prilinebuildout</a> command on page 3-75.)</li> <li>• <b>get:</b> Returns the current CSU setting (internal or external).</li> </ul>	Sets or gets the PRI CSU mode for a T1 interface. By default, the T1 PRI network interface module is set for internal CSU mode. User interface screen location: <b>System &gt; Admin Settings &gt; Network &gt; IDSN (page 2): External CSU</b> <b>Note:</b> This screen is only accessible if you have a PRI network interface connected to your system.	pricsu external
pridialchannels	<b>pridialchannels &lt;set get&gt; &lt;{1..12 1..15}&gt;</b> Where: <ul style="list-style-type: none"> <li>• <b>set:</b> Sets the number of PRI channels to be dialed in parallel when followed by a parameter from &lt;{1..12 1..15}&gt;. To erase the current setting, omit the parameter.</li> <li>• <b>get:</b> Returns the current number of channels dialed in parallel.</li> <li>• <b>{1..12 1..15}:</b> Range of numbers of PRI channels that can be dialed in parallel. For PRI T1, the range is 1..12. For PRI E1, the range is 1..15.</li> </ul>	Sets or gets the number of PRI channels to dial in parallel. By default, ISDN channels are dialed three at a time. On PRI systems, you can choose the number of channels to dial in parallel. User interface screen location: <b>System &gt; Admin Settings &gt; Network &gt; IDSN (page 4): Number of Active Channels</b> <b>Note:</b> This screen is only accessible if you have a PRI network interface connected to your system.	pridialchannels set 3
priintlprefix	<b>priintlprefix &lt;set get&gt; ["prefix"]</b> Where: <ul style="list-style-type: none"> <li>• <b>set:</b> Sets the PRI international dialing prefix when followed by the parameter "prefix". To erase the current setting, omit the parameter.</li> <li>• <b>get:</b> Returns the current setting.</li> <li>• <b>"prefix":</b> Numeric string.</li> </ul>	Sets or gets the PRI international dialing prefix. The international prefix defaults to 011 for North America and 00 for European countries. The default depends on the country. User interface screen location: <b>System &gt; Admin Settings &gt; Network &gt; IDSN (page 3): International Dialing Prefix</b> <b>Note:</b> This screen is only accessible if you have a PRI network interface connected to your system.	priintlprefix set 011

Command	Syntax	Description	Example
prilinebuild-out	<p><b>prilinebuildout &lt;set get&gt; &lt;“attenuation in dB” “attenuation in feet”&gt;</b></p> <p>Where:</p> <ul style="list-style-type: none"> <li>• <b>set:</b> Sets the PRI line buildout. It requires an output “attenuation in dB” or an “attenuation in feet”.</li> <li>• <b>get:</b> Returns the current setting.</li> <li>• <b>“attenuation in dB”:</b> Output attenuation values in dB. For internal CSUs. Available values are <ul style="list-style-type: none"> <li>□ 0</li> <li>□ -7.5</li> <li>□ -15</li> <li>□ -22.5</li> </ul> </li> <li>• <b>“attenuation in feet”:</b> Output attenuation values in feet. For external CSUs. Available values are: <ul style="list-style-type: none"> <li>□ 0-133</li> <li>□ 134-266</li> <li>□ 267-399</li> <li>□ 400-533</li> <li>□ 534-665</li> </ul> </li> </ul>	<p>Sets or gets the PRI line buildout for a T1 interface. If you are using an internal CSU, enter the output attenuation in dB. If you are using an external CSU, enter the output attenuation in feet.</p> <p>User interface screen location:  <b>System &gt; Admin Settings &gt; Network &gt; IDSN (page 3): Line Build Out</b></p>	<pre>prilinebuildout set -7.5</pre>

Command	Syntax	Description	Example
prilinesignal	<p><b>prilinesignal &lt;set get&gt; &lt;esf/b8zs crc4/hdb3 hdb3&gt;</b></p> <p>Where:</p> <ul style="list-style-type: none"> <li>• <b>set:</b> Sets the PRI line signal. It requires one of the following parameters: <ul style="list-style-type: none"> <li>□ esf/b8zs</li> <li>□ crc4/hdb3</li> <li>□ hdb3</li> </ul> </li> <li>• <b>get:</b> Returns the current PRI line signal setting.</li> <li>• <b>esf/b8zs:</b> A method of signal encoding used with a T1 interface. This is the only choice for T1. This value actually chooses both a framing format and an encoding method. Legacy frame formats, such as D4, are not supported. In addition, older encoding methods, such as B7ZS, are not supported.</li> <li>• <b>crc4/hdb3:</b> A method of signal encoding used with an E1 interface. This is the default value. Data is encoded using HDB3 to ensure proper one-density, and CRC4 error checking is enabled on both transmit and receive.</li> <li>• <b>hdb3:</b> A method of signal encoding used with an E1 interface. CRC4 error checking is disabled.</li> </ul>	<p>Sets or gets the PRI line signal.</p> <p>User interface screen location:  <b>System &gt; Admin Settings &gt; Network &gt; IDSN (page 2): Line Signaling</b></p> <p><b>Note:</b> This screen is only accessible if you have a PRI network interface connected to your system.</p>	<pre>prilinesignal set esf/b8zs</pre>
prinumber	<p><b>prinumber &lt;set get&gt; ["pri number"]</b></p> <p>Where:</p> <ul style="list-style-type: none"> <li>• <b>set:</b> Sets the PRI video number when followed by the parameter "pri number". To erase the current setting, omit the parameter.</li> <li>• <b>get:</b> Returns the current setting.</li> <li>• <b>"pri number":</b> Numeric string. This number is provided by your network service provider.</li> </ul>	<p>Sets or gets the PRI video number.</p> <p>User interface screen location:  <b>System &gt; Admin Settings &gt; Network &gt; IDSN: PRI Video Number</b></p> <p><b>Note:</b> This screen is only accessible if you have a PRI network interface connected to your system.</p>	<pre>prinumber set 5551212</pre>

Command	Syntax	Description	Example
prinumberingplan	<p><b>prinumberingplan</b> <b>&lt;isdn unknown get&gt;</b></p> <p>Where:</p> <ul style="list-style-type: none"> <li>• <b>isdn:</b> With this parameter, the numbering plan is identified to the upstream switch as ISDN, and the number type, which is either national or international, is determined from the dialed phone number. If the dialed phone number starts with the international dialing prefix that is currently selected, the type is set to the international and the prefix is removed from the number before the number is sent to the upstream switch. Otherwise, the number is marked as national and passed to the upstream switch without modification.</li> <li>• <b>unknown:</b> This is the default selection. With this parameter, the numbering plan and number type are sent to the upstream as unknown, and the dialed phone number is sent without notification. The “unknown” parameter is preferred and should work with all properly configured PBXs and with most telephone company switches. A notable exception in North America is an ATT 5ESS switch, which is provisioned with Accunet, or an ATT 4ESS switch. For these switches, set the numbering type to ISDN.</li> <li>• <b>get:</b> Returns the current setting.</li> </ul>	<p>Sets or gets the PRI numbering plan.</p> <p>User interface screen location: <b>System &gt; Admin Settings &gt; Network &gt; ISDN</b> (page 3): <b>Numbering Plan</b></p> <p><b>Note:</b> This screen is only accessible if you have a PRI network interface connected to your system.</p>	<pre>prinumberingplan isdn</pre>
prioutside-line	<p><b>prioutside-line</b> <b>&lt;set get&gt;</b> <b>["outside_line"]</b></p> <p>Where:</p> <ul style="list-style-type: none"> <li>• <b>set:</b> Sets the outside-line-access PRI number when followed by the parameter “outside_line”. To erase the current setting, omit the parameter.</li> <li>• <b>get:</b> Returns the current setting.</li> <li>• <b>“outside_line”:</b> Numeric string. This number is provided by your network service provider.</li> </ul>	<p>Sets or gets the PRI number that is dialed for outside line access. This number is needed if your system is on a PBX.</p> <p>User interface screen location: <b>System &gt; Admin Settings &gt; Network &gt; ISDN: Outside Line Dialing Prefix</b></p> <p><b>Note:</b> This screen is only accessible if you have a PRI network interface connected to a VSX system.</p>	<pre>prioutside-line set 9</pre>

Command	Syntax	Description	Example
priswitch	<p><b>priswitch &lt;set get&gt; &lt;"switch protocol"&gt;</b></p> <p>Where:</p> <ul style="list-style-type: none"> <li>• <b>set:</b> Sets the PRI switch. One of the "switch protocol" parameters is required.</li> <li>• <b>get:</b> Returns the current switch protocol.</li> <li>• <b>"switch protocol":</b> Switch protocol values are: <ul style="list-style-type: none"> <li>□ att5ess</li> <li>□ att4ess</li> <li>□ norteldms</li> <li>□ ni2</li> <li>□ net5/ctr4</li> </ul> </li> </ul> <p>For E1, net5/ctr4 is the default. Net5/ctr4 is the standard ETSI protocol derived from ITU Q.931. For T1, net5/ctr4 is also provided for certain Asian countries, such as Japan, Hong Kong, and Taiwan.</p>	<p>Sets or gets the PRI switch. If more than one switch protocol is supported, you must find out from your telephone service provider which protocol to select. NET5/CTR4 is the default. It is the standard ETSI protocol derived from ITU Q.931. If you change the country settings, a new set of PRI switch protocols is loaded.</p> <p>User interface screen location:  <b>System &gt; Admin Settings &gt; Network &gt; IDSN (page 3): Switch Protocol</b></p> <p><b>Note:</b> This screen is only accessible if you have a PRI network interface connected to your system.</p>	<pre>priswitch set norteldms</pre>
rt	<p><b>rt &lt;normal inverted get&gt;</b></p> <p>Where:</p> <ul style="list-style-type: none"> <li>• <b>normal:</b> Sets the signal to normal (rising edge receives data).</li> <li>• <b>inverted:</b> Sets the signal to inverted (falling edge receives data).</li> <li>• <b>get:</b> Returns the current setting for this option (normal or inverted).</li> </ul>	<p>Sets or gets the rt serial interface control signal (receive timing: clock) to normal or inverted. The default setting is "normal".</p> <p>User interface screen location:  <b>System &gt; Admin Settings &gt; Network &gt; V.35/RS-449/RS-530 (page 3): RT</b></p>	<pre>rt inverted</pre>
rts	<p><b>rts &lt;normal inverted get&gt;</b></p> <p>Where:</p> <ul style="list-style-type: none"> <li>• <b>normal:</b> Sets the signal to normal (high voltage is logic 1).</li> <li>• <b>inverted:</b> Sets the signal to inverted (low voltage is logic 1).</li> <li>• <b>get:</b> Returns the current setting (normal or inverted).</li> </ul>	<p>Sets or gets the rts serial interface control signal (request to send) to normal or inverted. The default setting is "normal".</p> <p>User interface screen location:  <b>System &gt; Admin Settings &gt; Network &gt; V.35/RS-449/RS-530 (page 3): RTS</b></p>	<pre>rts normal</pre>

Command	Syntax	Description	Example
spidnum	<p><b>spidnum &lt;set get&gt; &lt;“bchannel”&gt;</b>  <b>spidnum set &lt;“bchannel”&gt;</b>  <b>[“number”]</b>  <b>spidnum get &lt;“bchannel” all&gt;</b></p> <p>Where:</p> <ul style="list-style-type: none"> <li>• <b>set:</b> Sets the SPID number for a B channel line when followed by the “number” parameter. To erase the current setting, omit “number”.</li> <li>• <b>get:</b> Returns the current SPID number associated with a B channel of a particular line.</li> <li>• <b>“bchannel”:</b> The line and B channel. Valid values are:  1b1BRI line 1, B channel 1  1b2BRI line 1, B channel 2  2b1BRI line 2, B channel 1  2b2BRI line 2, B channel 2  3b1BRI line 3, B channel 1  3b2BRI line 3, B channel 2  4b1BRI line 4, B channel 1  4b2BRI line 4, B channel 2</li> <li>• <b>“number”:</b> Numeric string. SPID numbers are generally provided by your network service provider.</li> <li>• <b>all:</b> Returns SPIDs for all channels of all lines.</li> </ul>	<p>Sets the ISDN SPID numbers assigned to the BRI lines used by the VSX system. SPIDs generally apply only in the United States and Canada. If you are behind an internal phone system (PBX), SPIDs may not be required.</p>	<pre>spidnum set 1b1 5125551212</pre>
st	<p><b>st &lt;normal inverted get&gt;</b></p> <p>Where:</p> <ul style="list-style-type: none"> <li>• <b>normal:</b> Sets the signal to normal (falling edge sends data).</li> <li>• <b>inverted:</b> Sets the signal to inverted (rising edge sends data).</li> <li>• <b>get:</b> Returns the current setting for this option (normal or inverted).</li> </ul>	<p>Sets or gets the st serial interface control signal (send timing: clock) to normal or inverted. The default setting is “normal”.</p> <p>User interface screen location:  <b>System &gt; Admin Settings &gt; Network &gt; V.35/RS-449/RS-530 (page 3): ST</b></p>	<pre>st get</pre>
v35dialingprotocol	<p><b>v35dialingprotocol &lt;rs366 get&gt;</b></p> <p>Where:</p> <ul style="list-style-type: none"> <li>• <b>rs366:</b> Enables RS-366 as the dialing protocol. At this time, RS-366 is the only supported dialing protocol on the system.</li> <li>• <b>get:</b> Returns the current setting.</li> </ul>	<p>Selects the dialing protocol. Selecting a dialing protocol is <i>not</i> needed if you are using your DCE to dial the call or if you have a dedicated connection to the far site.</p>	<pre>v35dialingprotoco l rs366</pre>

Command	Syntax	Description	Example
v35num	<p><b>v35num &lt;set get&gt; &lt;1b1 1b2&gt; ["v35 number"]</b>  <b>v35num set &lt;1b1 1b2&gt; ["v35 number"]</b>  <b>v35num set &lt;1b1 1b2&gt;</b>  <b>v35num get &lt;1b1 1b2&gt;</b></p> <p>Where:</p> <ul style="list-style-type: none"> <li>• <b>set &lt;1b1 1b2&gt;</b>: Sets the ISDN video number for a B channel line when followed by a "v35 number" parameter. To erase the current setting, omit the "v35 number" parameter.</li> <li>• <b>get &lt;1b1 1b2&gt;</b>: Returns the current ISDN video number associated with a B channel of a particular line.</li> <li>• <b>1b1 1b2</b>: B1 and B2 channels: 1b1 designates line 1, B channel 1 (B1). 1b2 designates line 1, B channel 2 (B2).</li> <li>• <b>"v35 number"</b>: Numeric string. This is the ISDN video number(s) provided by your network service provider.</li> </ul>	<p>Sets or gets the ISDN video numbers assigned to the system. The 1b1 and 1b2 parameters follow the convention and nomenclature of the user interface and the <b>isdnum</b> command on page 3-71.</p>	<pre>v35num set 1b1 5125551212</pre>
v35portsused	<p><b>v35portsused &lt;1 1+2 get&gt;</b></p> <p>Where:</p> <ul style="list-style-type: none"> <li>• <b>1</b>: Selects one port for one-channel calls.</li> <li>• <b>1+2</b>: Selects two ports for two-channel calls (2 x 56 Kbps or 2 x 64 Kbps).</li> <li>• <b>get</b>: Returns the current setting (1 or 1+2).</li> </ul>	<p>Selects the number of ports to use on the V.35/RS-449/RS-530 network interface module.</p> <p>User interface screen location:  <b>System &gt; Admin Settings &gt; Network &gt; V.35/RS-449/RS-530: V.35 Ports Used</b></p>	<pre>v35portsused 1+2</pre>



Command	Syntax	Description	Example
v35prefix	<p><b>v35prefix &lt;set get&gt; &lt;"valid speed"&gt; ["value"]</b>  <b>v35suffix set &lt;"valid speed"&gt; ["value"]</b>  <b>v35suffix get &lt;"valid speed"&gt;</b></p> <p>Where:</p> <ul style="list-style-type: none"> <li>• <b>set "valid speed"</b>: Sets the V.35/RS-449/RS-530 prefix when followed by a "value" parameter. To erase the current setting, omit the "value".</li> <li>• <b>get "valid speed"</b>: Returns the current setting for "valid speed".</li> <li>• <b>"valid speed": Valid speeds:</b> 56, 64, 2x56, 112, 2x64, 128, 168, 192, 224, 256, 280, 320, 336, 384, 392, 7x64, 504, 512, 560, 576, 616, 640, 672, 704, 728, 768, 784, 832, 840, 14x64, 952, 960, 1008, 1024, 1064, 1088, 1120, 1152, 1176, 1216, 1232, 1280, 1288, 21x64, 1400, 1408, 1456, 1472, 1512, 1536, 1568, 1600, 1624, 1664, 1680, 1728, 28x64, 1856, 1920, all.</li> </ul> <p>The parameter <b>"all"</b> lists all the available speeds and their associated dialing prefixes.</p> <ul style="list-style-type: none"> <li>• <b>"value"</b>: V.35/RS-449/RS-530 prefix, which is a function of your DCE. Consult the DCE user guide for information.</li> </ul>	<p>Sets or gets the dialing prefix. It assumes that a profile has already been selected. See the <a href="#">v35profile</a> command on page 3-82.</p> <p>User interface screen location:  <b>System &gt; Admin Settings &gt; Network &gt; V.35/RS-449/RS-530 (page 2): Prefix</b></p>	<p>v35prefix set 112 "#005"</p> <p>This command associates the dialing prefix 005 to the speed 112.</p>

Command	Syntax	Description	Example
v35profile	<p><b>v35profile &lt;“available profile”[get view]&gt;</b></p> <p>Where:</p> <ul style="list-style-type: none"> <li>• <b>“available profile”:</b> V.35/RS-449/RS-530 profile (equipment/manufacturer) available. Available profiles are: <ul style="list-style-type: none"> <li><input type="checkbox"/> special_1</li> <li><input type="checkbox"/> special_2</li> <li><input type="checkbox"/> adtran</li> <li><input type="checkbox"/> adtran_isu512</li> <li><input type="checkbox"/> ascend</li> <li><input type="checkbox"/> ascend_vsx</li> <li><input type="checkbox"/> ascend_mb+</li> <li><input type="checkbox"/> ascend_max</li> <li><input type="checkbox"/> avaya_mcu</li> <li><input type="checkbox"/> fvc.com</li> <li><input type="checkbox"/> initia</li> <li><input type="checkbox"/> lucent_mcu</li> <li><input type="checkbox"/> madge_teleos</li> <li><input type="checkbox"/> promptus</li> </ul> </li> </ul> <p>Consult your DCE user guide for additional information on setting dialing profiles.</p> <ul style="list-style-type: none"> <li>• <b>get:</b> Returns the current profile.</li> <li>• <b>view:</b> Returns all the settings (speed, prefix or suffix) of the current profile.</li> </ul>	<p>Sets or gets a profile associated with dialing through a DCE. It can also display all the settings (speed, prefix or suffix) of the current profile.</p> <p>User interface screen location: <b>System &gt; Admin Settings &gt; Network &gt; V.35/RS-449/RS-530</b> (page 2): <b>Calling Profile</b></p>	<p>Example 1</p> <pre>v35profile adtran_isu512</pre> <p>Selects adtran_isu512 as the profile.</p> <p>Example 2</p> <pre>v35profile view</pre> <p>This example assumes adtran_isu512 as the current profile. The first column lists the available speeds for that profile. The second column lists the suffixes associated with each speed.</p> <pre>56          #3#0 64          #4#0 2x56       #3#0 112        #3#2 2x64       #4#0 128        #4#2 168        #3#3 192        #4#3 224        #3#4 256        #4#4 280        #3#5 320        #4#5 336        #3#6 384        #4#6 392        #3#7 7x64       #4#7 504        #3#8 512        #4#8 etc</pre>

Command	Syntax	Description	Example
v35suffix	<p><b>v35suffix &lt;set get&gt; &lt;"valid speed"&gt; ["value"]</b>  <b>v35suffix set &lt;"valid speed"&gt; ["value"]</b>  <b>v35suffix get &lt;"valid speed"&gt;</b></p> <p>Where:</p> <ul style="list-style-type: none"> <li>• <b>set:</b> When followed by a "valid speed" and a "value," sets the dialing suffix when followed by a "value" parameter. To erase the current setting, omit the "value" parameter.</li> <li>• <b>get:</b> Returns the current setting for valid speed.</li> <li>• <b>"valid speed":</b> Valid speeds: 56, 64, 2x56, 112, 2x64, 128, 168, 192, 224, 256, 280, 320, 336, 384, 392, 7x64, 504, 512, 560, 576, 616, 640, 672, 704, 728, 768, 784, 832, 840, 14x64, 952, 960, 1008, 1024, 1064, 1088, 1120, 1152, 1176, 1216, 1232, 1280, 1288, 21x64, 1400, 1408, 1456, 1472, 1512, 1536, 1568, 1600, 1624, 1664, 1680, 1728, 28x64, 1856, 1920, all.</li> </ul> <p>The parameter <b>"all"</b> lists all the available speeds and their associated dialing prefixes.</p> <ul style="list-style-type: none"> <li>• <b>"value":</b> The dialing suffix, which is a function of your DCE. Consult the DCE user guide for information.</li> </ul>	<p>Sets or gets the dialing suffix. It assumes that a profile has already been selected. See the <a href="#">v35profile</a> command on page 3-82.</p> <p>User interface screen location:  <b>System &gt; Admin Settings &gt; Network &gt; V.35/RS-449/RS-530 (page 2): Suffix</b></p>	<p>v35suffix set 128 "#4#2"</p> <p>This command associates the dialing suffix #4#2 to the speed 128.</p>

## Peripherals Commands

Command	Syntax	Description	Example
graphics-monitor	<p><b>graphicsmonitor</b>  <b>&lt;tv fxvga visualconcert 1 2 vcnx get&gt;</b></p> <p>Where:</p> <ul style="list-style-type: none"> <li>• <b>tv</b>: Selects the TV monitor as the graphics monitor. The graphics and video are displayed on the TV monitor.</li> <li>• <b>fxvga</b>: Selects the VSX system's VGA monitor as the graphics monitor. Enable this option if you have a high-resolution VGA monitor or projector connected to the rear panel of the system.</li> <li>• <b>vcnx</b>: Selects Visual Concert VSX as the graphics monitor. Enable this option if Visual Concert VSX is connected to your system and the graphics monitor is directly connected to Visual Concert VSX. This allows your system to display your computer desktop on your system's VGA monitor.</li> <li>• <b>get</b>: Returns the current setting.</li> </ul>	<p>Sets or gets the graphics monitor to one of three choices: a TV monitor, a VGA monitor, or a Visual Concert VSX monitor. When you use this command to set the graphics monitor, you automatically turn off the other two choices.</p> <p>User interface screen location:  <b>System &gt; Admin Settings &gt; Monitors &gt; Monitors: Graphics Content Display</b></p>	<pre>graphicsmonitor fxvga</pre>
monitor1	<p><b>monitor1&lt;4:3 16:9 get&gt;</b></p> <p>Where:</p> <ul style="list-style-type: none"> <li>• <b>4:3 16:9</b>: Sets the display format ratio to 4:3 (standard display) or 16:9 (wide-screen display).</li> <li>• <b>get</b>: Returns the current setting.</li> </ul>	<p>Sets the display format for monitor 1. User interface screen location:  <b>System &gt; Admin Settings &gt; Monitors &gt; Monitors: Monitor 1</b></p>	<pre>monitor1 4:3</pre>
monitor2	<p><b>monitor2 &lt;off 4:3 get&gt;</b></p> <p>Where:</p> <ul style="list-style-type: none"> <li>• <b>off</b>: The video signal is not sent out to the second monitor outputs.</li> <li>• <b>4:3</b>: Sets the display format ratio to 4:3 (standard).</li> <li>• <b>get</b>: Returns the current setting.</li> </ul>	<p>Sets the display format for monitor 2. User interface screen location:  <b>System &gt; Admin Settings &gt; Monitors &gt; Monitors: Monitor 2</b></p>	<pre>monitor2 4:3</pre>
sleep	<b>sleep</b>	Puts the VSX system in sleep mode.	<pre>sleep</pre>

Command	Syntax	Description	Example
sleeptext	<p><b>sleeptext &lt;set get&gt; ["text"]</b></p> <p>Where:</p> <ul style="list-style-type: none"> <li>• <b>set:</b> Sets the text to be displayed on the screen saver when followed by the "text" parameter. To erase the current setting, omit "text".</li> <li>• <b>get:</b> Returns the current text.</li> <li>• <b>"text":</b> Screen saver text to be displayed when the VSX system is in sleep mode. Enclose the text in quotation marks if it includes spaces.</li> </ul>	<p>Sets the text to be displayed on the screen saver when the system is in sleep mode.</p>	<pre>sleeptext set "Pick up the remote control to use the system"</pre>
sleeptime	<p><b>sleeptime &lt;0 1 3 15 30 60 120 240 480&gt; get&gt;</b></p> <p>Where:</p> <ul style="list-style-type: none"> <li>• <b>0, 1, 3, 15, 30, 60, 120, 240, 480:</b> Sets the number of minutes from last user interaction to entering sleep mode. The default value is 15.</li> <li>• <b>get:</b> Returns the current value.</li> </ul>	<p>Sets the wait time value before the VSX system goes to sleep and displays the screen saver.</p> <p>User interface screen location:  <b>System &gt; Admin Settings &gt; General Settings &gt; System Settings &gt; Appearance: Screen Saver Wait Time</b></p>	<pre>sleeptime 1</pre>
stream	<p><b>stream &lt;start stop&gt;</b></p> <p>Where:</p> <ul style="list-style-type: none"> <li>• <b>start:</b> Starts streaming. A meeting password may be required.</li> <li>• <b>stop:</b> Stops streaming.</li> </ul>	<p>Starts or stops streaming from your system.</p> <p>User interface screen location:  <b>System &gt; Utilities &gt; Streaming: Start Streaming</b></p> <p><b>Note:</b> This option is only visible on the main user interface screen if you have previously enabled Allow Streaming.</p>	<pre>stream start</pre>
streamann- nounce	<p><b>streamannoun- ce &lt;yes no get&gt;</b></p> <p>Where:</p> <ul style="list-style-type: none"> <li>• <b>yes:</b> Enables streaming announcement.</li> <li>• <b>no:</b> Disables streaming announcement.</li> <li>• <b>get:</b> Returns the current setting (yes or no).</li> </ul>	<p>Enables or disables streaming announcement. When this option is enabled, the names of users logged on to your system are displayed on screen.</p> <p>User interface screen location:  <b>System &gt; Admin Settings &gt; Network &gt; IP &gt; Streaming: Enable Streaming Announcement</b></p>	<pre>streamannoun- ce yes</pre>
streamau- dioport	<p><b>streamaudiop- ort &lt;set get&gt; ["stream audio port"]</b></p> <p>Where:</p> <ul style="list-style-type: none"> <li>• <b>set:</b> Sets the stream audio port when followed by the "stream audio port" parameter. To erase the current setting, omit the parameter.</li> <li>• <b>get:</b> Returns the current setting.</li> <li>• <b>"stream audio port":</b> Audio port number.</li> </ul>	<p>Sets or gets the stream audio port. By default, the audio port is a fixed port. This may be changed if a user needs to go through the firewall.</p> <p>User interface screen location:  <b>System &gt; Admin Settings &gt; Network &gt; IP &gt; Streaming: Audio Port</b></p>	<pre>streamaudiop- ort set 16384</pre>

Command	Syntax	Description	Example
streamenable	<p><b>streamenable &lt;yes no get&gt;:</b></p> <p>Where:</p> <ul style="list-style-type: none"> <li>• <b>yes:</b> Enables streaming.</li> <li>• <b>no:</b> Disables streaming.</li> <li>• <b>get:</b> Returns the current setting (yes or no).</li> </ul>	<p>Enables or disables streaming on the system.</p> <p>User interface screen location:  <b>System &gt; Admin Settings &gt; Network &gt; IP &gt; Streaming: Allow Streaming</b></p>	streamenable yes
streammulticastip	<p><b>streammulticastip &lt;set get&gt; ["ipaddress"]</b></p> <p>Where:</p> <ul style="list-style-type: none"> <li>• <b>set:</b> Sets the multicast IP address when followed by the "ipaddress" parameter. To erase the current setting, omit the parameter.</li> <li>• <b>get:</b> Returns the current setting.</li> <li>• <b>"ipaddress":</b> Multicast IP address.</li> </ul>	<p>Sets or gets the multicast IP address. A default address is entered for you based on your system's serial number. This ensures that you do not have the same multicast address as another Polycom system. You can change this default address using this command.</p> <p>User interface screen location:  <b>System &gt; Admin Settings &gt; Network &gt; IP &gt; Streaming: IP Multicast Address</b></p>	streammulticastip get
streamrestoredefaults	<p><b>streamrestoredefaults</b></p>	<p>Restores the stream Speed, IP Multicast Address, Number of Router Hops, Audio Port, and Video Port defaults and prints out the values.</p>	<pre>streamrestoredefaults returns information similar to this: streamspeed 192 streammulticastip 231.0.231.01 streamrouterhops 1 streamaudioport 16384 streamvideoport 16386 streamannounce yes streamenable no</pre>
streamrouterhops	<p><b>streamrouterhops &lt;set get&gt; ["number router hops"]</b></p> <p>Where:</p> <ul style="list-style-type: none"> <li>• <b>set:</b> Sets the number of routers when followed by the "number router hops" parameter. To erase the current setting, omit the parameter.</li> <li>• <b>get:</b> Returns the current setting.</li> <li>• <b>"number router hops":</b> Numeric value. Number of routers the streaming video has to pass through.</li> </ul>	<p>Sets or gets the number of routers you want the streaming video to pass through. This allows you to control who can see your streaming video.</p> <p>User interface screen location:  <b>System &gt; Admin Settings &gt; Network &gt; IP &gt; Streaming: Number of Router Hops (TTL)</b></p>	streamrouterhops set 1

Command	Syntax	Description	Example
stream-speed	<b>streamspeek &lt;192 256 384 512 get&gt;</b> Where: <ul style="list-style-type: none"> <li><b>192 256 384 512</b>: Sets the streaming speed at the designated number of Kbps.</li> <li><b>get</b>: Returns the current setting.</li> </ul>	Sets or gets the speed of the video stream. User interface screen location: <b>System &gt; Admin Settings &gt; Network &gt; IP &gt; Streaming: Speed</b>	streamspeek 256
stream-videoport	<b>streamvideoport &lt;set get&gt; ["video port"]</b> Where: <ul style="list-style-type: none"> <li><b>set</b>: Sets the stream video port when followed by the "video port" parameter. To erase the current setting, omit the parameter.</li> <li><b>get</b>: Returns the current setting.</li> <li><b>"video port"</b>: Video port number.</li> </ul>	Sets or gets the stream video port. By default, the video port is a fixed port. This command lets you can change stream video port to go through a firewall. User interface screen location: <b>System &gt; Admin Settings &gt; Network &gt; IP &gt; Streaming: Video Port</b>	streamvideoport 16386
vcrrcord-source	<b>vcrrcordsource &lt;auto near far get&gt;</b> Where: <ul style="list-style-type: none"> <li><b>auto</b>: Enables the VCR to automatically record the current speaker in a point-to-point call.</li> <li><b>near</b>: Enables the VCR to record the near-site presentation.</li> <li><b>far</b>: Enables the VCR to record the far-site presentation.</li> <li><b>get</b>: Returns the current setting (auto, near or far).</li> </ul>	Sets or gets the VCR record source. User interface screen location: <b>System &gt; Admin Settings &gt; Cameras &gt; VCR: VCR Record Source</b>	vcrrcordsource auto
vcstream	<b>vcstream &lt;state register unregister&gt;</b> Where: <ul style="list-style-type: none"> <li><b>state</b>: Returns the current status of the Visual Concert content stream.</li> <li><b>register</b>: Registers the Visual Concert stream so that changes to the stream will be displayed to the API control device, and reports the current status of the stream.</li> <li><b>unregister</b>: Unregisters the Visual Concert stream.</li> </ul>	Gets the current state of the Visual Concert stream, or registers or unregisters for notification of state changes in the stream.	vcstream state returns vcstream state no video
vtxstate	<b>vtxstate get</b>	Returns the current state of the SoundStation™ VTX 1000 conference phone.	vtxstate get Possible return values are vtxattached vtxattachedonhook vtxattachedoffhook vtxdetached vtxerror

## Polycom Tools Commands

Command	Syntax	Description	Example
all register	<p><b>all register</b></p> <p>Registers changes to any of the following types of parameters:</p> <ul style="list-style-type: none"> <li>• Current near-site or far-site source</li> <li>• State of privacy</li> <li>• Current volume level</li> <li>• Active camera presets</li> <li>• Status of point-to-point or multipoint calls</li> <li>• Status of physical ISDN/IP connection to codec</li> <li>• PIP state</li> <li>• Visual Concert state</li> <li>• Chair control</li> <li>• System information</li> <li>• Gatekeeper status</li> </ul>	<p>Simultaneously registers all user feedback so that the API reports all user actions. This command is particularly useful when two different control systems are being used simultaneously, such as the web and API commands. The system maintains the registration changes through restarts.</p> <p>This command also returns all current settings.</p> <p>To unregister user feedback, use the <b>all unregister</b> command.</p> <p><b>Note:</b> The function and syntax of <b>all register</b> and <b>registerall</b> are identical.</p>	all register
all unregister	<p><b>all unregister</b></p> <p>The following types of parameters are unregistered:</p> <ul style="list-style-type: none"> <li>• Current near-site or far-site source</li> <li>• State of privacy</li> <li>• Current volume level</li> <li>• Active camera presets</li> <li>• Status of point-to-point or multipoint calls</li> <li>• Status of physical ISDN/IP connection to codec</li> <li>• PIP state</li> <li>• Visual Concert state</li> <li>• Chair control</li> <li>• System information</li> <li>• Gatekeeper status</li> </ul>	<p>Simultaneously unregisters all registered user feedback so that the API no longer reports changes to the parameters listed in the Syntax column.</p> <p><b>Note:</b> The function and syntax of <b>all unregister</b> and <b>unregisterall</b> are identical.</p>	all unregister



Command	Syntax	Description	Example
button	<p><b>button &lt;"name"&gt;</b> Where "<b>name</b>" can be:</p> <p><b>#:</b> Sends the # key to the user interface.</p> <p><b>*</b>: Sends the * key to the user interface.</p> <p><b>0-9:</b> Sends the corresponding numeric key to the user interface.</p> <p><b>auto:</b> Sends the Auto key to the user interface.</p> <p><b>back:</b> Simulates the Back icon on multiple-page screens.</p> <p><b>callhangup:</b> Sends the Call Hang-Up key to the user interface.</p> <p><b>camera:</b> Sends the Camera key to the user interface.</p> <p><b>delete:</b> Sends the Delete key to the user interface.</p> <p><b>directory:</b> Sends the Directory key to the user interface.</p> <p><b>down:</b> Sends the down arrow key to the user interface.</p> <p><b>far:</b> Sends the Far key to the user interface.</p> <p><b>graphics:</b> Sends the graphics key to the user interface.</p> <p><b>help:</b> Sends the Info command to the user interface.</p> <p><b>home:</b> Takes the user to the main screen.</p> <p><b>keyboard:</b> Brings up the on-screen keyboard if the cursor is on a text field.</p> <p><b>left:</b> Sends the left (left arrow) command to the user interface.</p> <p><b>lowbattery:</b> Sends the remote control low battery signal.</p> <p><b>mute:</b> Sends the Mute key to the user interface, causing a toggle of mute state.</p> <p><b>near:</b> Sends the Near key to the user interface.</p> <p><b>period:</b> Types a period (dot) if the cursor is on a text field.</p> <p><b>pickedup:</b> Sends a signal indicating that the remote control has been picked up (remote control feet are out).</p> <p><b>pip:</b> Sends the PIP key to the user interface.</p> <p><b>preset:</b> Sends the Preset key to the user interface.</p>	<p>Allows the user to send the same command as the Polycom remote control to the user interface. Note that several parameters can be combined in the same command in any order.</p> <p>The command is not checked prior to being sent to the user interface. The VSX system produces a warning sound if there is no function for that button on the currently active screen.</p> <p><b>Note:</b> The button commands are available only for backward compatibility, and are not recommended.</p>	<p>Example 1</p> <pre>button up</pre> <p>This command sends the up arrow command to the user interface.</p> <p>Example 2</p> <pre>button near left right callhangup</pre> <p>This valid command combines the following commands:</p> <pre>button near button left button right button callhangup</pre>

Command	Syntax	Description	Example
button (continued)	<p><b>putdown:</b> Sends signal indicating that the remote control has been set down (remote control feet are pushed in).</p> <p><b>right:</b> Sends the right key to the user interface (right arrow).</p> <p><b>select:</b> Sends the select key (center button) command to the user interface.</p> <p><b>snapshot:</b> Function not implemented.</p> <p><b>up:</b> Sends the up (up arrow) key to the user interface.</p> <p><b>volume+:</b> Sends the Volume + key to the user interface.</p> <p><b>volume-:</b> Sends the Volume - key to the user interface.</p> <p><b>zoom+:</b> Sends the Zoom in key to the user interface.</p> <p><b>zoom-:</b> Sends the Zoom out key to the user interface.</p>		
con- figchange	<p><b>configchange &lt;register unregister&gt;</b> Where:</p> <ul style="list-style-type: none"> <li>• <b>register:</b> Registers to receive notifications when configuration variables have changed.</li> <li>• <b>unregister:</b> Unregisters to receive notifications when configuration variables have changed.</li> </ul>	Specifies whether to receive notifications when configuration variables have changed.	
country	<p><b>country &lt;set get&gt;</b> <b>country set &lt;"countryname"&gt;</b> Where:</p> <ul style="list-style-type: none"> <li>• <b>set:</b> Sets the country. A country name parameter is required. Use quotation marks around a compound name or strings containing spaces (Example: "united states").</li> <li>• <b>get:</b> Returns the current setting.</li> <li>• <b>"countryname":</b> name of a country from the system's country list. For a list of countries, type <code>country set</code> in the API help.</li> </ul>	Selects the country or returns the name of the country. This allows you to specify country-specific calling parameters for your location. User interface screen location: <b>System &gt; Admin Settings &gt; General Settings &gt; Location: Country</b>	<pre>country set germany country set "united states"</pre>
daylightsav- ings	<p><b>daylightsavings &lt;yes no get&gt;</b> Where:</p> <ul style="list-style-type: none"> <li>• <b>yes:</b> Enables daylight savings time.</li> <li>• <b>no:</b> Disables daylight savings time.</li> <li>• <b>get:</b> Returns the status of this option (yes or no).</li> </ul>	Sets the daylight savings time. User interface screen location: <b>System &gt; Admin Settings &gt; General Settings &gt; Location (page 2): Daylight Saving Time</b>	<pre>daylightsavings yes</pre>

Command	Syntax	Description	Example
dialingdisplay	<p><b>dialingdisplay</b>  <b>&lt;dialingentry displaymarquee none get&gt;</b></p> <p>Where:</p> <ul style="list-style-type: none"> <li>• <b>dialingentry:</b> Displays a field for users to enter numbers manually.</li> <li>• <b>display marquee:</b> Displays text in the dialing entry field. Users cannot enter numbers manually when this option is selected. The text displayed is specified by the <b>marqueedisplaytext</b> command.</li> <li>• <b>none:</b> Removes the dialing entry field from the display.</li> <li>• <b>get:</b> Returns the current setting.</li> </ul>	<p>Configures the home screen dialing display.</p> <p>User interface screen location:  <b>System &gt; Admin Settings &gt; General Settings &gt; Home Screen Settings: Dialing Display</b></p>	<p>dialingdisplay  none</p>
displayipext	<p><b>displayipext &lt;yes no get&gt;</b></p> <p>Where:</p> <ul style="list-style-type: none"> <li>• <b>yes:</b> Enables the display of the IP extension.</li> <li>• <b>no:</b> Enables the display of the IP extension.</li> <li>• <b>get:</b> Returns the current setting (yes or no).</li> </ul>	<p>Sets or gets the display of the IP extension field. This extension is needed when placing a call through a gateway. When this option is selected, the Extension field is visible in the Place a Call screen.</p> <p>User interface screen location:  <b>System &gt; Admin Settings &gt; Network &gt; IP &gt; H.323 Settings: Display H.323 Extension</b></p>	<p>displayipext yes</p>

Command	Syntax	Description	Example
display-params	<b>displayparams</b>	Outputs the list of all the system settings.	<pre> displayparams returns information similar to this: systemname Jw hostname Jw ipaddress 192.168.1.104 wanipaddress 192.168.1.111 version 7.0 - 31Jul2004 14:12 serialnum XXXXX allowremotemonito ring no daylightsavings yes requireacctnumtod ial no validateacctnum no timediffgmt -12:00 gmsurl 1 &lt;empty&gt; gmsurl 2 &lt;empty&gt; gmsurl 3 &lt;empty&gt; gmsurl 4 &lt;empty&gt; gmsurl 5 &lt;empty&gt; gmsurl 6 &lt;empty&gt; gmsurl 7 &lt;empty&gt; gmsurl 8 &lt;empty&gt; gmsurl 9 &lt;empty&gt; gmsurl 10 &lt;empty&gt; gmscontactperson &lt;empty&gt; gmscontactnumber &lt;empty&gt; gmscontactemail &lt;empty&gt; gmscontactfax &lt;empty&gt; gmstechsupport &lt;empty&gt; gmscity &lt;empty&gt; gmsstate &lt;empty&gt; gmscountry &lt;empty&gt; gabserverip &lt;empty&gt; gabpassword &lt;empty&gt; displayglobaladdr esses no </pre>

Command	Syntax	Description	Example
display-params (continued)			<pre> registerthissystem no showaddrsingab both primarycallchoice manual secondarycallchoice none preferredalias extension gatewaynumber type number+extension outboundcallroute isdn usegatekeeper off numdigitsdid 7 numdigitsext 4 gatewaycountrycode &lt;empty&gt; gatewayareacode &lt;empty&gt; gatewaynumber &lt;empty&gt; gatekeeperip &lt;empty&gt; h323name Jw e164ext 59715 gatewayext 59715 usepathnavigator required ..... </pre>
enablesnmp	<b>enablesnmp &lt;yes no get&gt;</b> Where: <ul style="list-style-type: none"> <li><b>yes:</b> Enables the SNMP option.</li> <li><b>no:</b> Disables the SNMP option.</li> <li><b>get:</b> Returns the current setting (yes or no).</li> </ul>	Enables or disables SNMP. This option is enabled by default. User interface screen location: <b>System &gt; Admin Settings &gt; Global Services &gt; SNMP: Enable SNMP</b>	enablesnmp yes
gabpassword	<b>gabpassword &lt;set get&gt; ["password"]</b> Where: <ul style="list-style-type: none"> <li><b>set:</b> Sets the GDS password to "password". To erase the current setting, omit "password".</li> <li><b>"password":</b> Password to access the GDS server. Valid characters are: a through z (lower and uppercase), -, _, @, /, ;, ,, ,, \, 0 through 9. Enclose the string in quotation marks if it includes spaces.</li> </ul>	Sends the password to gain access to the Global Directory Server (GDS) server. <b>Note:</b> This command cannot be used unless an admin password has been set. User interface screen location: <b>System &gt; Admin Settings &gt; Global Services &gt; Directory Servers: Password</b>	gabpassword set gabPass

Command	Syntax	Description	Example
gabserverip	<b>gabserverip &lt;set get&gt; ["ipaddress"]</b> Where: <ul style="list-style-type: none"> <li>• <b>set:</b> Sets the GDS server's IP address when followed by the parameter "ipaddress". To erase the current setting, omit "ipaddress".</li> <li>• <b>get:</b> Returns the current setting.</li> <li>• <b>"ipaddress":</b> IP address of the GDS server. Can be a numeric or character string.</li> </ul>	Sets the IP address of the Global Directory Server (GDS) server.  User interface screen location: <b>System &gt; Admin Settings &gt; Global Services &gt; Directory Servers: Global Directory (GDS)</b>	gabserverip set gab.polycom.com server
get screen	<b>get screen</b>	Returns the name of the current screen so that the control panel programmer knows which screen the user interface is currently displaying.	get screen Output sample: screen: generatetone
gmscity	<b>gmscity &lt;set get&gt;["city"]</b> Where: <ul style="list-style-type: none"> <li>• <b>set:</b> Sets the GMS city name when followed by the "city" parameter.</li> <li>• <b>Note:</b> Enclose the string in quotation marks if it includes spaces. Example: "San Antonio". To erase the current setting, omit "city".</li> <li>• <b>get:</b> Returns the current setting.</li> <li>• <b>"city":</b> Character string specifying the city.</li> </ul>	Sets the Global Management System (GMS) city information.  User interface screen location: <b>System &gt; Admin Settings &gt; Global Services &gt; My Information: City</b>	gmscity set Paris
gmscontactemail	<b>gmscontactemail &lt;set get&gt; ["email"]</b> Where: <ul style="list-style-type: none"> <li>• <b>set:</b> Sets the GMS contact E-mail address when followed by the "email" parameter. To erase the current setting, omit "email".</li> <li>• <b>get:</b> Returns the current contact E-mail address.</li> <li>• <b>"email":</b> Alphanumeric string specifying the E-mail address.</li> </ul>	Sets the GMS contact E-mail information.  User interface screen location: <b>System &gt; Admin Settings &gt; Global Services &gt; My Information: Contact Email</b>	gmscontactemail set gms_manager@mycompany.com
gmscontactfax	<b>gmscontactfax &lt;set get&gt; ["fax"]</b> Where: <ul style="list-style-type: none"> <li>• <b>set:</b> Sets the GMS contact fax information when followed by the "fax" parameter. To erase the current setting, omit "fax".</li> <li>• <b>get:</b> Returns the current contact fax information.</li> <li>• <b>"fax":</b> Character string specifying the fax number. Enclose the string in quotation marks if it includes spaces. Example: "512 555 1212".</li> </ul>	Sets the GMS contact fax information  User interface screen location: <b>System &gt; Admin Settings &gt; Global Services &gt; My Information: Contact Fax</b>	gmscontactfax "512 555 1212"

Command	Syntax	Description	Example
gmscontact-number	<p><b>gmscontactnumber &lt;set get&gt; ["number"]</b></p> <p>Where:</p> <ul style="list-style-type: none"> <li>• <b>set:</b> Sets the GSM contact number when followed by the "number" parameter. To erase the current setting, omit "number".</li> <li>• <b>get:</b> Returns the current contact number.</li> <li>• <b>"number":</b> Numeric string specifying the contact number. Enclose the string in quotation marks if it includes spaces. Example: "512 555 1212".</li> </ul>	<p>Sets the GSM contact number information.</p> <p>User interface screen location: <b>System &gt; Admin Settings &gt; Global Services &gt; My Information: Contact Number</b></p>	<pre>gmscontactnumber set "512 555 1212"</pre>
gmscontact-person	<p><b>gmscontactperson &lt;set get&gt; ["person"]</b></p> <p>Where:</p> <ul style="list-style-type: none"> <li>• <b>set:</b> Sets the GSM contact person name when followed by the "person" parameter. To erase the current setting, omit "person".</li> <li>• <b>get:</b> Returns the current contact person information.</li> <li>• <b>"person":</b> Character string specifying the contact person. Enclose the string in quotation marks if it includes spaces. Example: "John Doe"</li> </ul>	<p>Sets the GSM contact person information.</p> <p>User interface screen location: <b>System &gt; Admin Settings &gt; Global Services &gt; My Information: Contact Person</b></p>	<pre>gmscontactperson set "John GSMadmin"</pre>
gmscountry	<p><b>gmscountry &lt;set get&gt; ["countryname"]</b></p> <p>Where:</p> <ul style="list-style-type: none"> <li>• <b>set:</b> Sets the GSM country information when followed by the "countryname" parameter. To erase the current setting, omit "countryname".</li> <li>• <b>get:</b> Returns the current country setting.</li> <li>• <b>"countryname":</b> Character string specifying the country. Enclose the string in quotation marks if it includes spaces. Example: "united states"</li> </ul>	<p>Sets the GSM country information</p> <p>User interface screen location: <b>System &gt; Admin Settings &gt; Global Services &gt; My Information: Country</b></p>	<pre>gmscountry set Argentina</pre>

Command	Syntax	Description	Example
gmsstate	<p><b>gmsstate &lt;set get&gt; ["state"]</b></p> <p>Where:</p> <ul style="list-style-type: none"> <li>• <b>set:</b> Sets the GMS state information when followed by the "state" parameter. To erase the current setting, omit the "state" parameter.</li> <li>• <b>get:</b> Returns the current state information.</li> <li>• <b>"state":</b> Character string specifying the state information. Enclose the string in quotation marks if it includes spaces. Example: "West Virginia"</li> </ul>	<p>Sets the GMS state information.</p> <p>User interface screen location: <b>System &gt; Admin Settings &gt; Global Services &gt; My Information: State/Province</b></p>	<pre>gmsstate set Texas</pre>
gmstech-support	<p><b>gmstechsupport &lt;set get&gt; ["number"]</b></p> <p>Where:</p> <ul style="list-style-type: none"> <li>• <b>set:</b> Sets the technical support information when followed by the "number" parameter. To erase the current setting, omit "number".</li> <li>• <b>get:</b> Returns the current tech support phone number information.</li> <li>• <b>"number":</b> Numeric string specifying the tech support phone number. Enclose the string in quotation marks if it includes spaces. Example: "512 555 1212"</li> </ul>	<p>Sets the GMS technical support number information.</p> <p>User interface screen location: <b>System &gt; Admin Settings &gt; Global Services &gt; My Information: Tech Support</b></p>	<pre>gmstechsupport set "123 456 7890"</pre>
gmsurl	<p><b>gmsurl &lt;get&gt; &lt;{1..10} all&gt; ["ipaddress"]</b></p> <p>Where:</p> <ul style="list-style-type: none"> <li>• <b>get:</b> Returns the current URL information for a selected server. A server must be specified.</li> <li>• <b>{1..10}:</b> GMS server number. The primary GMS server that performs account validation is always server 1.</li> <li>• <b>all:</b> Specifies that information for all GMS servers is to be returned.</li> <li>• <b>"ipaddress":</b> IP address of the URL server.</li> </ul>	<p>Returns the URL of the GMS server that manages your system. When you are registered with the GMS, this information is automatically configured.</p> <p>User interface screen location: <b>System &gt; Admin Settings &gt; Global Services &gt; Management Servers</b></p>	<pre>gmsurl get 1 returns: gmsurl 1 192.168.1.123</pre>
home-callquality	<p><b>homecallquality &lt;yes no get&gt;</b></p> <p>Where:</p> <ul style="list-style-type: none"> <li>• <b>yes:</b> Enables the Call Quality option.</li> <li>• <b>no:</b> Disables the Call Quality option.</li> <li>• <b>get:</b> Returns the current setting (yes or no).</li> </ul>	<p>Specifies whether users are allowed to select the bandwidth for calls from the home screen.</p> <p>User interface screen location: <b>System &gt; Admin Settings &gt; General Settings &gt; Home Screen Settings: Call Quality</b></p>	<pre>homecallquality yes</pre>



Command	Syntax	Description	Example
homemulti-point	<p><b>homemultipoint &lt;yes no get&gt;</b></p> <p>Where:</p> <ul style="list-style-type: none"> <li><b>yes:</b> Displays the <b>Multipoint</b> button on the home screen.</li> <li><b>no:</b> Removes the <b>Multipoint</b> button from the home screen.</li> <li><b>get:</b> Returns the current setting (yes or no).</li> </ul>	<p>Specifies whether users are allowed to access the multipoint dialing screen via a <b>Multipoint</b> button on the home screen.</p> <p>User interface screen location:  <b>System &gt; Admin Settings &gt; General Settings &gt; Home Screen Settings: Multipoint</b></p> <p><b>Note:</b> This option is only available if Multipoint is enabled.</p>	<pre>homemultipoint yes</pre>
homerecentcalls	<p><b>homerecentcalls &lt;yes no get&gt;</b></p> <p>Where:</p> <ul style="list-style-type: none"> <li><b>yes:</b> Enables the Recent Calls option.</li> <li><b>no:</b> Disables the Recent Calls option.</li> <li><b>get:</b> Returns the current setting (yes or no).</li> </ul>	<p>Specifies whether users are allowed to access a list of recent calls made with the system by displaying the <b>Recent Calls</b> button on the home screen.</p> <p>User interface screen location:  <b>System &gt; Admin Settings &gt; General Settings &gt; Home Screen Settings</b> (page 2):  <b>Recent Calls</b></p> <p><b>Note:</b> This option is only available if the Call Detail Report option is enabled.</p>	<pre>homerecentcalls yes</pre>
homesystem	<p><b>homesystem &lt;yes no get&gt;</b></p> <p>Where:</p> <ul style="list-style-type: none"> <li><b>yes:</b> Enables the System option.</li> <li><b>no:</b> Disables the System option.</li> <li><b>get:</b> Returns the current setting (yes or no).</li> </ul>	<p>Specifies whether allowed to access the system screen by displaying the <b>System</b> button on the home screen.</p> <p>User interface screen location:  <b>System &gt; Admin Settings &gt; General Settings &gt; Home Screen Settings: System</b></p>	<pre>homesystem yes</pre>
homesystemname	<p><b>homesystemname &lt;yes no get&gt;</b></p> <p>Where:</p> <ul style="list-style-type: none"> <li><b>yes:</b> Displays the system name on the home screen.</li> <li><b>no:</b> Removes the system name from the home screen.</li> <li><b>get:</b> Returns the current setting (yes or no).</li> </ul>	<p>Specifies whether to display the name of the system on the home screen above the PIP window.</p> <p>User interface screen location:  <b>System &gt; Admin Settings &gt; General Settings &gt; Home Screen Settings</b> (page 2):  <b>System Name</b></p>	<pre>homesystemname yes</pre>

Command	Syntax	Description	Example
language	<p><b>language &lt;set get&gt;</b>  <b>language set &lt;"language"&gt;</b></p> <p>Where:</p> <ul style="list-style-type: none"> <li>• <b>set:</b> Sets the specified language. Requires a "language" parameter.</li> <li>• <b>get:</b> Returns the current language used on the system.</li> <li>• <b>"language":</b> Must be one of the following: <ul style="list-style-type: none"> <li>❑ englishus</li> <li>❑ englishuk</li> <li>❑ french</li> <li>❑ german</li> <li>❑ italian</li> <li>❑ spanish</li> <li>❑ japanese</li> <li>❑ portuguese</li> <li>❑ norwegian</li> <li>❑ korean</li> <li>❑ traditional chinese</li> <li>❑ chinese</li> </ul> </li> </ul>	<p>Selects the language that will display on the VSX system.</p> <p>User interface screen location:  <b>System &gt; Admin Settings &gt; General Settings &gt; Location: Language</b></p>	<pre>language set german</pre>
listen	<p><b>listen &lt;video sleep&gt;</b></p> <p>Where:</p> <ul style="list-style-type: none"> <li>• <b>video:</b> Instructs the session to listen for incoming video calls. When this event occurs, the message "listen video ringing" is received.</li> <li>• <b>sleep:</b> Instructs the session to listen for when the system goes into sleep mode. When this event occurs, the message "listen going to sleep" is received. When the system wakes up, the message "listen wake up" is received.</li> </ul>	<p>Registers the RS-232 session to listen for incoming video calls, or system sleep or awake state and, consequently, to give notification when the registered state occurs.</p>	<pre>listen sleep returns: listen sleep registered  to acknowledge that the session is now registered to listen for sleep mode.  listen going to sleep  Notification of event: the system is going to sleep mode.  listen waking up  Notification of event: the system is waking up.</pre>
localdate- tetime	<p><b>localdatetime &lt;yes no get&gt;</b></p> <p>Where:</p> <ul style="list-style-type: none"> <li>• <b>yes:</b> Displays the local date and time on the home screen.</li> <li>• <b>no:</b> Removes the local date and time from the home screen.</li> <li>• <b>get:</b> Returns the current setting (yes or no).</li> </ul>	<p>Specifies whether to display the local date and time on the home screen.</p> <p>User interface screen location:  <b>System &gt; Admin Settings &gt; General Settings &gt; Home Screen Settings (page 2): Local Date and Time</b></p>	<pre>localdatetime yes</pre>

Command	Syntax	Description	Example
marqueedisplaytext	<p><b>marqueedisplaytext &lt;set get&gt;</b></p> <p>Where:</p> <ul style="list-style-type: none"> <li><b>set:</b> Sets the text to display in the dialing entry field followed by the text to use. Enclose the string in quotation marks if it includes spaces.</li> <li><b>get:</b> Returns the current marquee display text.</li> </ul>	<p>Specifies the text to display in the dialing entry field on the home screen.</p> <p>User interface screen location:  <b>System &gt; Admin Settings &gt; General Settings &gt; Home Screen Settings: Enter Marquee Text</b></p> <p><b>Note:</b> This option is only available when <b>dialingdisplay</b> is set to <b>display marquee</b>.</p>	<pre>marqueedisplaytext "select an entry from the directory"</pre>
ntpmode	<p><b>ntpmode &lt;auto off manual get&gt;</b></p> <p>Where:</p> <ul style="list-style-type: none"> <li><b>auto:</b> Automatically selects an NTP server from the Internet.</li> <li><b>off:</b> Turns off the use of an NTP server.</li> <li><b>manual:</b> Lets you specify a server using the <b>ntpserver</b> command on page 3-99.</li> <li><b>get:</b> Returns the current time server mode.</li> </ul>	<p>Sets or gets the mode of the system's Network Time Protocol (NTP) server. NTP server time is used to ensure synchronized time data in the local Call Detail Report.</p> <p>User interface screen location:  <b>System &gt; Admin Settings &gt; Network &gt; IP &gt; H.323 Settings &gt; NTP Setup</b></p>	<pre>ntpmode auto</pre>
ntpserver	<p><b>ntpserver &lt;set get&gt; &lt;"DNS name or ipaddress"&gt;</b></p> <p>Where:</p> <ul style="list-style-type: none"> <li><b>set:</b> Sets the IP address of the NTP server when followed by a valid parameter.</li> <li><b>get:</b> Gets the IP address of the NTP server.</li> <li><b>"DNS name or ipaddress":</b> The DNS name or IP address of the NTP server.</li> </ul>	<p>Sets or gets an Network Time Protocol (NTP) server, using the IP address or the DNS name of the server. This allows you to use an internal time server and thus synchronize the system's time with the time on your internal network. The system uses this time only for the local Call Detail Report.</p> <p>User interface screen location:  <b>System &gt; Admin Settings &gt; Network &gt; IP &gt; H.323 Settings &gt; NTP Setup</b></p>	<pre>ntpserver set time.xyzcorp.com</pre>

Command	Syntax	Description	Example
popupinfo	<p><b>popupinfo &lt;register unregister&gt;</b></p> <p>Where:</p> <ul style="list-style-type: none"> <li>• <b>register</b>: Registers to receive popup information.</li> <li>• <b>unregister</b>: Unregisters to receive popup information.</li> </ul>	Registers or unregisters to receive popup text and button choices text.	<pre>popupinfo register later returns something like this if a call fails: popupinfo: ques- tion: Sorry. Cannot dial number because you are already in a call with the site. popupinfo: choice0: Ok or if the user edits the password field, the API feedback is: popupinfo: ques- tion: Save Changes? popupinfo: choice0: Yes popupinfo: choice1: No popupinfo: answered: Yes</pre>
rs232 baud	<p><b>rs232 baud</b> <b>&lt;1200 2400 9600 14400 19200 38400</b> <b> 57600 115200 get&gt;</b></p> <p>Where:</p> <ul style="list-style-type: none"> <li>• <b>9600, 14400, 19200, 38400, 57600, 115200</b>: Sets the RS-232 port to this baud rate.</li> <li>• <b>get</b>: Returns the current baud rate setting.</li> </ul>	<p>Configures the RS-232 port baud rate.</p> <p>User interface screen location: <b>System &gt; Admin Settings &gt; General Settings &gt; Serial Port: Baud Rate</b></p>	rs232 baud 9600

Command	Syntax	Description	Example
rs232 mode	<p><b>rs232 mode</b>  <b>&lt;passthru control debug sony_ptz closed_caption vortex_mixer get&gt;</b></p> <p>Where:</p> <ul style="list-style-type: none"> <li>• <b>passthru</b>: Sets the RS-232 port to Pass Thru mode.</li> <li>• <b>control</b>: Sets the RS-232 port to Control mode.</li> <li>• <b>debug</b>: Sets the RS-232 port to Debug mode.</li> <li>• <b>sony_ptz</b>: Sets the RS-232 port to Sony PTZ mode.</li> <li>• <b>closed_caption</b>: Sets the RS-232 port to Closed Caption mode.</li> <li>• <b>vortex_mixer</b>: Sets the RS-232 port to Vortex Mixer mode.</li> <li>• <b>get</b>: Returns the current mode setting.</li> </ul>	<p>Configures the RS-232 port mode.</p> <p>User interface screen location:  <b>System &gt; Admin Settings &gt; General Settings &gt; Serial Port: RS-232 Mode</b></p>	rs232 mode control
run	<p><b>run &lt;"scriptfilename"&gt;</b></p> <p>Where:</p> <ul style="list-style-type: none"> <li>• <b>scriptfilename</b>: Name of the script file containing the API commands to be executed.</li> </ul>	<p>Loads a file from the flash file system and then executes the API commands contained in it. Each command needs to be placed on a single line with a &lt;CR&gt;&lt;LF&gt; as a terminator.</p>	run startcall.bat
screen	<p><b>screen [register unregister "screen_name"]</b></p> <p>Where:</p> <ul style="list-style-type: none"> <li>• <b>register</b>: Registers for user interface screen changes. In register mode, the name of every screen accessed is listed.</li> <li>• <b>unregister</b>: Terminates the register mode.</li> <li>• <b>"screen_name"</b>: Changes the user interface to display the specified screen. Omit this parameter to get the name of the current screen.</li> </ul>	<p>Returns the name of the current user interface screen on the VSX system, registers or unregisters for screen changes, or goes to a specific user interface screen.</p>	<p><b>Example 1</b></p> <pre>screen returns information similar to this: screen: adminsettings</pre> <p><b>Example 2</b></p> <pre>screen register returns information similar to this: screen registered systemsetup adminsettings- screen: monitors screen: tvmonitors screen: cameras</pre>
showpopup	<p><b>showpopup &lt;"text"&gt;</b></p> <p>Where:</p> <ul style="list-style-type: none"> <li>• <b>"text"</b>: Message to display to users. Enclose the text in quotation marks.</li> </ul>	<p>Displays a message box in the user interface.</p>	<pre>showpopup "The conference will resume in three minutes."</pre>

Command	Syntax	Description	Example
snapshot-timeout	<p><b>snaphottimeout &lt;yes no get&gt;</b></p> <p>Where:</p> <ul style="list-style-type: none"> <li>• <b>yes:</b> Enables the option: the display times out after four minutes and the system returns to live video.</li> <li>• <b>no:</b> Disables the option: the snapshot stays on screen indefinitely.</li> <li>• <b>get:</b> Returns the current setting (yes or no).</li> </ul>	<p>Enables or disables the Snapshot Timeout option. By default, all slides and snapshots are displayed for a period of four minutes. When the display times out after four minutes, the VSX system automatically returns to live video. However, when this option is disabled, the snapshot or slide stays on screen indefinitely until the user presses the SNAP button on the remote control to return to live video.</p> <p>User interface screen location:  <b>System &gt; Admin Settings &gt; Monitors &gt; Monitors: Snapshot Timeout</b></p>	<pre>snaphottimeout no</pre>
snmpadmin	<p><b>snmpadmin &lt;set get&gt; ["admin name"]</b></p> <p>Where:</p> <ul style="list-style-type: none"> <li>• <b>set:</b> Sets the administrator name when followed by the "admin name" parameter. To erase the current setting, omit "admin name".</li> <li>• <b>get:</b> Returns the current setting.</li> <li>• <b>"admin name":</b> SNMP administrator contact name. Character string. Enclose the character string in quotation marks if it includes spaces. Example: "John Admin"</li> </ul>	<p>Sets or gets the SNMP administrator name.</p> <p>User interface screen location:  <b>System &gt; Admin Settings &gt; Global Services &gt; SNMP: Contact Name</b></p>	<pre>snmpadmin set "John Admin"</pre>
snmpcommunity	<p><b>snmpcommunity &lt;set get&gt; ["community name"]</b></p> <p>Where:</p> <ul style="list-style-type: none"> <li>• <b>set:</b> Sets the SNMP community name when followed by the "community name" parameter. To erase the current setting, omit the parameter.</li> <li>• <b>get:</b> Returns the current setting.</li> <li>• <b>"community name":</b> SNMP community name. Character string. Enclose the character string in quotation marks if it includes spaces.</li> </ul>	<p>Sets or gets the SNMP community name.</p> <p>User interface screen location:  <b>System &gt; Admin Settings &gt; Global Services &gt; SNMP: Community</b></p>	<pre>snmpcommunity set Public</pre>

Command	Syntax	Description	Example
snmpconsoleip	<b>snmpconsoleip &lt;set get&gt; ["ipaddress"]</b> Where: <ul style="list-style-type: none"> <li>• <b>set:</b> Sets the SNMP console IP address when followed by the "ipaddress" parameter. To erase the current setting, omit the parameter.</li> <li>• <b>get:</b> Returns the current setting.</li> <li>• <b>"ipaddress":</b> IP address of the console.</li> </ul>	Sets or gets the SNMP console IP address.  User interface screen location: <b>System &gt; Admin Settings &gt; Global Services &gt; SNMP: Console IP Address</b>	<pre>snmpconsoleip set 192.168.1.111</pre>
snmplocation	<b>snmplocation &lt;set get&gt; ["location name"]</b> Where: <ul style="list-style-type: none"> <li>• <b>set:</b> Sets the SNMP location name when followed by the "location name" parameter. To erase the current setting, omit the parameter.</li> <li>• <b>get:</b> Returns the current setting.</li> <li>• <b>"location name":</b> SNMP location name. Enclose the location name in quotation marks if it includes spaces.</li> </ul>	Sets or gets the SNMP location name.  User interface screen location: <b>System &gt; Admin Settings &gt; Global Services &gt; SNMP: Location Name</b>	<pre>snmplocation set "john_EX in United States"</pre>
snmpsystemdescription	<b>snmpsystemdescription &lt;set get&gt; ["system description"]</b> Where: <ul style="list-style-type: none"> <li>• <b>set:</b> Sets the SNMP system description when followed by the "system description" parameter. To erase the current setting, omit the parameter.</li> <li>• <b>get:</b> Returns the current setting.</li> <li>• <b>"system description":</b> SNMP system description.</li> </ul>	Sets or gets the SNMP system description.  User interface screen location: <b>System &gt; Admin Settings &gt; Global Services &gt; SNMP: System Description</b>	<pre>snmpsystemdescription set "videoconferencing system"</pre>
subwooferoffset	<b>subwooferoffset &lt;+3 +2 +1 0 -1 -2 -3 get&gt;</b> Where: <ul style="list-style-type: none"> <li>• <b>+3, +2, +1, 0, -1, -2, -3:</b> Sets the subwoofer to this level dB.</li> <li>• <b>get:</b> Returns the current subwoofer dB level.</li> </ul>	Sets the volume level for the subwoofer without changing the master audio volume. (VSX 7000 only)  User interface screen location: <b>System &gt; Admin Settings &gt; Audio (page 3): Subwoofer Level</b>	<pre>subwooferoffset +2</pre>

Command	Syntax	Description	Example
textinput	<b>textinput &lt;"text to input"&gt;</b> Where: <ul style="list-style-type: none"> <li>• <b>"text to input"</b>: Alphanumeric string to be inserted into the selected edit box. If the string includes spaces, enclose it in quotation marks. Example: "Pacific Room"</li> </ul>	Inserts text into a user interface edit box that you have already selected using the remote control.  This command would insert the text "Pacific Room" into a selected user interface edit box (for example, the System Name edit box in the General Settings screen of the user interface).	<pre>textinput "Pacific Room"</pre>
timediffgmt	<b>timediffgmt &lt;{-12:00..+12:00}&lt;get&gt;</b> Where: <ul style="list-style-type: none"> <li>• <b>{-12:00..+12:00}</b>: Sets the time difference from GMT to this value. +00:00 is GMT time.</li> <li>• <b>get</b>: Returns the current setting.</li> </ul>	Sets or gets the time difference from where the system is installed and Greenwich Mean Time (GMT). This allows the Global Management System to view the local time of the managed system.  User interface screen location: <b>System &gt; Admin Settings &gt; General Settings &gt; Location</b> (page 2): <b>Time Difference from GMT</b>	<pre>timediffgmt -06:00</pre>
traceroute	<b>traceroute &lt;host&gt; [hops]</b> Where: <ul style="list-style-type: none"> <li>• <b>host</b>: hostname or an IP address and 0 &lt; hops &lt; 100</li> </ul>	Runs a trace route to test. If successful, displays the routing path between the local system and the IP address entered.  User interface screen location: <b>System &gt; Diagnostics &gt; Network &gt; Trace Route</b>	<pre>traceroute might return something like -&gt;traceroute polycom.com hostname poly- com.com (207.171.166.102) testlan tracer- oute complete. 29 hops.</pre>



Command	Syntax	Description	Example
usepath-navigator	<p><b>usepathnavigator</b>  <b>&lt;always never required get&gt;</b></p> <p>Where:</p> <ul style="list-style-type: none"> <li>• <b>always:</b> Always use PathNavigator to place a multipoint call. Never use the external MCU.</li> <li>• <b>never:</b> Never use PathNavigator to place a multipoint call. Use the external MCU instead.</li> <li>• <b>required:</b> This is the default. When this option is selected, if the multipoint call is within the MCU capabilities, it is handled by the MCU; otherwise, beyond the MCU capabilities, it is handled through the PathNavigator/MGC.</li> <li>• <b>get:</b> Returns the current setting (always, never, or required).</li> </ul>	<p>Selects the PathNavigator™ mode, if PathNavigator is used with the system. Because PathNavigator uses an MGC, it can handle video conferences with more participants and higher speeds than an embedded MCU. PathNavigator, which supports ad-hoc multipoint video conferencing, is required to implement Conference on Demand™. Conference on Demand allows users to bring multiple endpoints together in a video conference on an unscheduled basis. It allows users to place multipoint video calls to remote participants by only using their names and/or numbers that correspond to those remote locations.</p> <p><b>Note:</b> This option is only accessible if PathNavigator is used.</p> <p>User interface screen location:  <b>System &gt; Admin Settings &gt; Network &gt; IP &gt; H.323 Settings</b> (page 2): <b>Use PathNavigator for Multipoint Calls</b></p>	<pre>usepathnavigator required</pre>
wake	<b>wake</b>	This command wakes the system from sleep mode. To put the system in sleep mode, use the <b>sleep</b> command on page 3-84.	wake
webport	<p><b>webport &lt;set get&gt; [N]</b></p> <p>Where:</p> <ul style="list-style-type: none"> <li>• <b>set:</b> Sets the web access port to N.</li> <li>• <b>get:</b> Returns the current setting.</li> </ul>	<p>Specifies the port to use when accessing the system using VSX Web. If you change this from the default (port 80), you will need to include the port number with the IP address when you use VSX Web to access the system. This makes unauthorized access more difficult.</p> <p>User interface screen location:  <b>System &gt; Admin Settings &gt; General Settings &gt; Security</b> (page 2): <b>Web Access Port</b></p>	<pre>webport set 80 returns: webaccessport 80 restart system for changes to take effect. restart now? &lt;y,n&gt;</pre>

Command	Syntax	Description	Example
winsserver	<p><b>winsserver &lt;set get&gt; ["xxx.xxx.xxx.xxx"]</b></p> <p>Where:</p> <ul style="list-style-type: none"> <li>• <b>set:</b> Sets the WINS server IP address to "<b>xxx.xxx.xxx.xxx</b>". To erase the current setting, omit the parameter.</li> <li>• <b>get:</b> Returns the WINS server setting.</li> </ul>	<p>Sets or gets the WINS server. After a change is made, the system prompts you for a restart.</p> <p>User interface screen location:  <b>System &gt; Admin Settings &gt; LAN Properties &gt; WINS Server</b></p> <p><b>Note:</b> This option is only available if <b>IP Address</b> is set to <b>Enter IP address manually</b> on the LAN Properties screen.</p>	winsserver get

## Security and Permissions Commands

Command	Syntax	Description	Example
adminpassword	<p><b>adminpassword &lt;set get&gt; ["password"]</b></p> <p>Where:</p> <ul style="list-style-type: none"> <li><b>set:</b> Sets the password used for remote management of the VSX system if followed by the password parameter. To erase the current setting, omit the password parameter. The VSX system must have an admin password set before this command works.</li> <li><b>get:</b> Returns the current admin password.</li> <li><b>"password":</b> User-defined password. Valid characters are: a through z (lower and uppercase), -, _, @, /, ;, ,, \, 0 through 9. The length is limited to 10 characters. If the password string includes spaces, enclose it in quotation marks.</li> </ul>	<p>Set the administrator password.</p> <p>User interface screen location:  <b>System &gt; Admin Settings &gt; General Settings &gt; Security: Admin Password</b></p>	<pre>adminpassword set MyVSXpsswd adminpassword set "VSX 2004"</pre>
allowabkchanges	<p><b>allowabkchanges &lt;yes no get&gt;</b></p> <p>Where:</p> <ul style="list-style-type: none"> <li><b>yes:</b> Enables the Allow Directory Changes option.</li> <li><b>no:</b> Disables the Allow Directory Changes option.</li> <li><b>get:</b> Returns the current setting (yes or no).</li> </ul>	<p>Enables or disables the Allow Directory Changes option. If this option is enabled, the user has access to the New, Edit, and Delete icons in the Directory screen.</p> <p>User interface screen location:  <b>System &gt; Admin Settings &gt; General Settings &gt; System Settings &gt; Directory: Allow Directory Changes</b></p>	<pre>allowabkchanges get</pre>
allowcamerapresetssetup	<p><b>allowcamerapresetssetup &lt;yes no get&gt;</b></p> <p>Where:</p> <ul style="list-style-type: none"> <li><b>yes:</b> Allows presets to be changed.</li> <li><b>no:</b> Does not allow presets to be changed.</li> <li><b>get:</b> Returns the current setting (yes or no).</li> </ul>	<p>Gets or sets whether camera presets can be changed.</p>	<pre>allowcamerapreset ssetup no</pre>

Command	Syntax	Description	Example
allowdialing	<b>allowdialing &lt;yes no get&gt;</b> Where: <ul style="list-style-type: none"> <li>• <b>yes:</b> Allows users to place calls.</li> <li>• <b>no:</b> Disables dialing so that the VSX system can only receive calls.</li> <li>• <b>get:</b> Returns the current setting (yes or no).</li> </ul>	Enables or disables the Allow Dialing option. User interface screen location: <b>System &gt; Admin Settings &gt; General Settings &gt; Home Screen Settings: Dialing Display</b>	allowdialing get
allowuser-setup	<b>allowuser-setup &lt;yes no get&gt;</b> Where: <ul style="list-style-type: none"> <li>• <b>yes:</b> Enables the User Settings icon.</li> <li>• <b>no:</b> Disables the User Settings icon.</li> <li>• <b>get:</b> Returns the current setting (yes or no).</li> </ul>	Enables or disables the User Settings icon on the System screen of the user interface, thus preventing access to the User Settings screen. This option is useful to prevent users from changing the User Settings functions. User interface screen location: <b>System &gt; Admin Settings &gt; General Settings &gt; Security: Allow Access to User Settings</b>	allowuser-setup yes
callencryption	<b>callencryption &lt;required disabled get&gt;</b> Where: <ul style="list-style-type: none"> <li>• <b>required:</b> Sets call encryption to be used for every call when it is available.</li> <li>• <b>disabled:</b> Disables call encryption.</li> <li>• <b>get:</b> Returns the current setting (required or disabled).</li> </ul>	Sets or gets the encryption mode. Use encryption when the far site is capable of encryption.	callencryption required
confirm-diradd	<b>confirm-diradd &lt;yes no get&gt;</b> Where: <ul style="list-style-type: none"> <li>• <b>yes:</b> When adding an entry to the Directory (Address Book), the user is prompted with the message "Are you sure you want to add this entry?"</li> <li>• <b>no:</b> The user will not be prompted when adding an entry.</li> <li>• <b>get:</b> Returns the current setting (yes or no).</li> </ul>	Confirms directory additions. User interface screen location: <b>System &gt; Admin Settings &gt; General Settings &gt; System Settings &gt; Directory: Confirm Directory Additions</b>	confirm-diradd yes

Command	Syntax	Description	Example
confirm-dirdel	<b>confirmdir</b> del <yes no get> Where: <ul style="list-style-type: none"> <li>• <b>yes</b>: When deleting an entry from the Directory (Address Book), the user is prompted with “Are you sure you want to delete this entry?”</li> <li>• <b>no</b>: When deleting an entry from the Directory (Address Book), the user is no prompted with a message.</li> <li>• <b>get</b>: Returns the current setting (yes or no).</li> </ul>	Confirms directory deletions. User interface screen location: <b>System &gt; Admin Settings &gt; General Settings &gt; System Settings &gt; Directory: Confirm Directory Deletions</b>	confirmdir del no
displayglobaladdresses	<b>displayglobaladdresses</b> <yes no get> Where: <ul style="list-style-type: none"> <li>• <b>yes</b>: Enables the display of global addresses.</li> <li>• <b>no</b>: Disables the display of global addresses.</li> <li>• <b>get</b>: Returns the current setting (yes or no).</li> </ul>	Enables/disables the display of global addresses in the Global Directory (GDS). User interface screen location: <b>System &gt; Admin Settings &gt; Global Services &gt; Directory Servers: Display Global Addresses</b>	displayglobal addresses yes
encryption	<b>encryption</b> <yes no get> Where: <ul style="list-style-type: none"> <li>• <b>yes</b>: Enables encryption.</li> <li>• <b>no</b>: Disables encryption.</li> <li>• <b>get</b>: Returns the status of this option (yes or no).</li> </ul>	Sets the encryption mode. User interface screen location: <b>System &gt; Admin Settings &gt; Security &gt; AES Encryption</b> <b>Note:</b> The Encryption options are only visible on the user interface if an encryption key has been entered.	encryption yes
natconfig	<b>natconfig</b> <auto manual off get> Where: <ul style="list-style-type: none"> <li>• <b>auto</b>: Specifies that the system is behind a NAT; specifies that the system will automatically discover the public (WAN) address.</li> <li>• <b>manual</b>: Specifies that the system is behind a NAT. Requires the WAN address to be assigned using the <a href="#">wanipaddress</a> command on page 3-68.</li> <li>• <b>off</b>: Disables the option.</li> <li>• <b>get</b>: Returns the current setting.</li> </ul>	Specifies how to configure the NAT. User interface screen location: <b>System &gt; Admin Settings &gt; Network &gt; IP &gt; Firewall: NAT Configuration</b>	natconfig manual

## Video Commands

Command	Syntax	Description	Example
backlight-compensation	<p><b>backlightcompensation &lt;yes no get&gt;</b></p> <p>Where:</p> <ul style="list-style-type: none"> <li>• <b>yes</b>: Enables Backlight Compensation. The camera automatically adjusts for a bright background.</li> <li>• <b>no</b>: Disables the option.</li> <li>• <b>get</b>: Returns the current setting (yes or no).</li> </ul>	<p>Enables or disables the Backlight Compensation option</p> <p>User interface screen location:  <b>System &gt; Admin Settings &gt; Cameras: Backlight Compensation</b></p>	backlightcompensation no
display-graphics	<p><b>displaygraphics &lt;yes no get&gt;</b></p> <p>Where:</p> <ul style="list-style-type: none"> <li>• <b>yes</b>: Enables the display of graphic icons.</li> <li>• <b>no</b>: Disables the display of graphic icons.</li> <li>• <b>get</b>: Returns the current setting (yes or no).</li> </ul>	<p>Sets or gets the display of graphic icons while in a call.</p> <p>User interface screen location:  <b>System &gt; Admin Settings &gt; Monitors &gt; Monitors: Display Icons in a Call</b></p>	displaygraphics yes
dualmonitor	<p><b>dualmonitor &lt;yes no get&gt;</b></p> <p>Where:</p> <ul style="list-style-type: none"> <li>• <b>yes</b>: Enables dual monitor emulation.</li> <li>• <b>no</b>: Disables dual monitor emulation.</li> <li>• <b>get</b>: Returns the current setting (yes or no).</li> </ul>	<p>Specifies whether both sites are displayed in a split-screen mode when using one monitor.</p> <p>User interface screen location:  <b>System &gt; Admin Settings &gt; Monitors &gt; Monitors: Dual Monitor Emulation</b></p>	dualmonitor yes

Command	Syntax	Description	Example
graphics-monitor	<p><b>graphicsmonitor</b> <b>&lt;tv fxvga 1 2 vcnx get&gt;</b></p> <p>Where:</p> <ul style="list-style-type: none"> <li>• <b>tv</b>: Selects the TV monitor as the graphics monitor. The graphics and video are displayed on the TV monitor.</li> <li>• <b>fxvga</b>: Selects the VSX system's VGA monitor as the graphics monitor. Enable this option if you have a high-resolution VGA monitor or projector connected to the rear panel of the system.</li> <li>• <b>1</b>: Selects Monitor 1 as the graphics monitor.</li> <li>• <b>2</b>: Selects Monitor 2 as the graphics monitor.</li> <li>• <b>vcnx</b>: Selects Visual Concert VSX as the graphics monitor. Enable this option if Visual Concert VSX is connected to your system and the graphics monitor is directly connected to Visual Concert VSX. This allows your system to display your computer desktop on your system's VGA monitor.</li> <li>• <b>get</b>: Returns the current setting.</li> </ul>	<p>Sets or gets the graphics monitor to one of these choices: a TV monitor, a VGA monitor, Monitor 1, Monitor 2, or a Visual Concert VSX monitor. When you use this command to set the graphics monitor, you automatically turn off the other two choices.</p> <p>User interface screen location: <b>System &gt; Admin Settings &gt; Monitors &gt; Monitors: Graphics Content Display</b></p>	<pre>graphicsmonitor fxvga</pre>
monitor1	<p><b>monitor1</b><b>&lt;4:3 16:9 get&gt;</b></p> <p>Where:</p> <ul style="list-style-type: none"> <li>• <b>4:3 16:9</b>: Sets the display format ratio to 4:3 (standard display) or 16:9 (wide-screen display).</li> <li>• <b>get</b>: Returns the current setting.</li> </ul>	<p>Sets the display format for monitor 1.</p> <p>User interface screen location: <b>System &gt; Admin Settings &gt; Monitors &gt; Monitors: Monitor 1</b></p>	<pre>monitor1 4:3</pre>
monitor2	<p><b>monitor2</b> <b>&lt;off 4:3 vga get&gt;</b></p> <p>Where:</p> <ul style="list-style-type: none"> <li>• <b>off</b>: The video signal is not sent out to the second monitor outputs.</li> <li>• <b>4:3</b>: Sets the display format ratio to 4:3 (standard).</li> <li>• <b>vga</b>: Sets the display to VGA.</li> <li>• <b>get</b>: Returns the current setting.</li> </ul>	<p>Sets the display format for monitor 2.</p> <p>User interface screen location: <b>System &gt; Admin Settings &gt; Monitors &gt; Monitors: Monitor 2</b></p>	<pre>monitor2 4:3</pre>
numberofmonitors	<p><b>numberofmonitors</b> <b>&lt;1 2 get&gt;</b></p> <p>Where:</p> <ul style="list-style-type: none"> <li>• <b>1, 2</b>: Sets the number of monitors allowed.</li> <li>• <b>get</b>: Returns the current setting (1 or 2).</li> </ul>	<p>Sets or gets the number of TV monitors that are connected to the system.</p>	<pre>numberofmonitors 2</pre>

Command	Syntax	Description	Example
pip	<p><b>pip &lt;on off auto swap get&gt;</b></p> <p>Where:</p> <ul style="list-style-type: none"> <li>• <b>on</b>: Enables PIP mode. The VSX system shows a PIP window that remains in the lower right corner of the screen until the video call is completed.</li> <li>• <b>off</b>: Disables PIP mode.</li> <li>• <b>auto</b>: The VSX system shows a PIP window when the call is first connected and when the remote control is not resting on a flat surface.</li> <li>• <b>swap</b>: Toggles the content of the PIP and the main display between the near-site and far-site view.</li> <li>• <b>get</b>: Returns the current setting for PIP mode (on, off, or auto).</li> </ul>	<p>Sets the on-screen PIP mode. The PIP feature allows the near site to adjust near-camera views while in a video conference.</p> <p>User interface screen location:  <b>System &gt; Admin Settings &gt; Monitors &gt; Monitors &gt; PIP</b></p> <p>or</p> <p><b>System &gt; User Settings</b> (page 2): <b>PIP</b></p> <p><b>Note:</b> The Allow Access to User Settings option under <b>System &gt; Admin Settings &gt; General Settings &gt; System Settings</b> (page 2) must be checked for the User Settings option to be available.</p>	pip auto



# Appendix

## Status Display

---

The call status can be displayed in a number of ways. The **getcallstate** command shows a table listing the status, speed, and dialed number of current calls.

To display real-time status on individual B channels (incoming or outgoing calls), either register the terminal session with the **callstate register listen** command, described on [page 3-45](#) or start an outbound call with the **dial** command, described on [page 3-25](#). These two commands will cause the system to re-direct the B channel status messages to the session which has issued one of these two commands. For example, if the RS-232 device issues a **dial** or **listen** command, then call status is directed to the RS-232 port; if a later session on a Telnet port issues a **dial** or **listen** command, then call status is also directed to that Telnet port.

## B Channel Status Message Example

---

The following output example is for B channel status messages, where:

cs	Indicates call status for one B channel.
RINGING	Indicates a ring-in or ring-out and is equivalent to a 25% blue sphere on the graphical user interface.
CONNECTED	Is equivalent to a 50% yellow sphere.
BONDING	Indicates the bonding protocol is operational on the channel and is equivalent to a 75% orange sphere.
COMPLETE	Is equivalent to a 100% green sphere.

### Example:

```
->dial man 384 5551212 ISDN
Dialing manual
Dialing 5551212 384 none ISDN
cs: call[0] chan[0] dialstr[95551212] state[RINGING]
```

```
cs: call[0] chan[0] dialstr[95551212] state[CONNECTED]
cs: call[0] chan[0] dialstr[95551212] state[BONDING]
cs: call[0] chan[0] dialstr[95551212] state[COMPLETE]
cs: call[0] chan[1] dialstr[95551212] state[RINGING]
cs: call[0] chan[1] dialstr[95551212] state[CONNECTED]
cs: call[0] chan[2] dialstr[95551212] state[RINGING]
cs: call[0] chan[3] dialstr[95551212] state[RINGING]
cs: call[0] chan[2] dialstr[95551212] state[CONNECTED]
cs: call[0] chan[3] dialstr[95551212] state[CONNECTED]
cs: call[0] chan[4] dialstr[95551212] state[RINGING]
cs: call[0] chan[5] dialstr[95551212] state[RINGING]
cs: call[0] chan[4] dialstr[95551212] state[CONNECTED]
cs: call[0] chan[5] dialstr[95551212] state[CONNECTED]
cs: call[0] chan[1] dialstr[95551212] state[BONDING]
cs: call[0] chan[2] dialstr[95551212] state[BONDING]
cs: call[0] chan[3] dialstr[95551212] state[BONDING]
cs: call[0] chan[4] dialstr[95551212] state[BONDING]
cs: call[0] chan[5] dialstr[95551212] state[BONDING]
cs: call[0] chan[0] dialstr[95551212] state[COMPLETE]
cs: call[0] chan[1] dialstr[95551212] state[COMPLETE]
cs: call[0] chan[2] dialstr[95551212] state[COMPLETE]
cs: call[0] chan[3] dialstr[95551212] state[COMPLETE]
cs: call[0] chan[4] dialstr[95551212] state[COMPLETE]
cs: call[0] chan[5] dialstr[95551212] state[COMPLETE]
active: call[0] speed[384]
->
->hangup video 0
hanging up video call
cleared:call[0] line[1] bchan[0] cause[16] dialstring[95551212]
cleared:call[0] line[2] bchan[0] cause[16] dialstring[95551212]
cleared:call[0] line[0] bchan[0] cause[16] dialstring[95551212]
cleared:call[0] line[1] bchan[1] cause[16] dialstring[95551212]
cleared: call[0] line[2] bchan[1] cause[16] dialstring[ ]
cleared: call[0] line[0] bchan[1] cause[16] dialstring[95551212]
ended call[0]

-> listen video
```

```
listen video registered
->
->listen video ringing // there is an incoming call, auto answer is
on
->cs: call[0] chan[0] dialstr[8005551212] state[RINGING]
cs: call[0] chan[0] dialstr[8005551212] state[CONNECTED]
cs: call[0] chan[0] dialstr[8005551212] state[BONDING]
cs: call[0] chan[0] dialstr[8005551212] state[COMPLETE]
cs: call[0] chan[1] dialstr[8005551212] state[RINGING]
cs: call[0] chan[1] dialstr[8005551212] state[CONNECTED]
cs: call[0] chan[2] dialstr[8005551212] state[RINGING]
cs: call[0] chan[3] dialstr[8005551212] state[RINGING]
cs: call[0] chan[2] dialstr[8005551212] state[CONNECTED]
cs: call[0] chan[3] dialstr[8005551212] state[CONNECTED]
cs: call[0] chan[6] dialstr[8005551212] state[RINGING]
cs: call[0] chan[6] dialstr[8005551212] state[CONNECTED]
cs: call[0] chan[4] dialstr[8005551212] state[RINGING]
cs: call[0] chan[5] dialstr[8005551212] state[RINGING]
cs: call[0] chan[4] dialstr[8005551212] state[CONNECTED]
cs: call[0] chan[5] dialstr[8005551212] state[CONNECTED]
cs: call[0] chan[7] dialstr[8005551212] state[RINGING]
cs: call[0] chan[7] dialstr[8005551212] state[CONNECTED]
cs: call[0] chan[1] dialstr[8005551212] state[BONDING]
cs: call[0] chan[2] dialstr[8005551212] state[BONDING]
cs: call[0] chan[3] dialstr[8005551212] state[BONDING]
cs: call[0] chan[6] dialstr[8005551212] state[BONDING]
cs: call[0] chan[4] dialstr[8005551212] state[BONDING]
cs: call[0] chan[5] dialstr[8005551212] state[BONDING]
cs: call[0] chan[7] dialstr[8005551212] state[BONDING]
cs: call[0] chan[0] dialstr[8005551212] state[COMPLETE]
cs: call[0] chan[1] dialstr[8005551212] state[COMPLETE]
cs: call[0] chan[2] dialstr[8005551212] state[COMPLETE]
cs: call[0] chan[3] dialstr[8005551212] state[COMPLETE]
cs: call[0] chan[6] dialstr[8005551212] state[COMPLETE]
cs: call[0] chan[4] dialstr[8005551212] state[COMPLETE]
cs: call[0] chan[5] dialstr[8005551212] state[COMPLETE]
cs: call[0] chan[7] dialstr[8005551212] state[COMPLETE]
active: call[0] speed[512]
```

